



25 Frame Plunger Pump

Standard Brass Model

2530

Stainless Steel Model

2531

Nickel Aluminum Bronze Model

2537

FEATURES

Superior Design

- Triplex plunger design gives smoother liquid flow.
- Hi-Pressure Seals are completely lubricated and cooled by the liquid being pumped.
- Inlet and discharge valve assemblies interchange for easier maintenance.
- Lubricated Lo-Pressure Seals provide double protection against external leakage.
- Oil bath crankcase assures optimum lubrication.
- Close tolerance concentricity of the ceramic plunger maximizes seal life.

Quality Materials

- Precision design 316SSL valves and seats are hardened and polished for ultimate seating and extended valve life.
- Brass, 316 Stainless Steel or Nickel Aluminum Bronze manifolds are strong and corrosion resistance.
- Special concentric, high-density, polished, solid ceramic plungers provide a true wear surface and extended seal life.
- Specially formulated, CAT PUMP exclusive, Hi-Pressure Seal offers unmatched performance and seal life.
- Die cast aluminum crankcase provides high strength, minimum weight and precision tolerance control.
- Chrome-moly crankshaft gives unmatched strength and surface hardness.
- Oversized crankshaft bearings with greater loading capacity mean longer bearing life.

Easy Maintenance

- Wet-end is easily serviced without entering crankcase, requiring less time and effort.
- Preset packings mean no packing gland adjustment is necessary, reducing maintenance costs.

SPECIFICATIONS

U.S. Measure

Metric Measure

MODELS 2530 AND 2531

Flow25 GPM (95 L/M)
 Pressure Range.....100 to 1000 PSI (7 to 70 BAR)
 RPM1025 RPM (1025 RPM)

MODEL 2537

Flow21 GPM (80 L/M)
 Pressure Range.....100 to 1200 PSI (7 to 85 BAR)
 RPM860 RPM (860 RPM)

COMMON SPECIFICATIONS

Inlet Pressure RangeFlooded to 70 PSI (Flooded to 4.9 BAR)
 Bore.....1.260" (32 mm)
 Stroke.....1.516" (38.5 mm)
 Crankcase Capacity84 oz. (2.5 L)
 Maximum Liquid Temperature160°F (71°C)
 For temperatures above 130°F call CAT PUMPS for inlet conditions and elastomer recommendations.
 Inlet Ports (2)1-1/4" NPTF (1-1/4" NPTF)
 Discharge Ports (2).....3/4" NPTF (3/4" NPTF)
 Pulley MountingEither Side (Either Side)
 Shaft Diameter1.181" (30 mm)
 Weight.....82 lbs. (37.1 kg)
 Dimensions.....19.11 x 15.04 x 7.8" (485.44 x 382 x 198 mm)

ELECTRIC HORSEPOWER REQUIREMENTS

MODEL	FLOW		PRESSURE			RPM
	U.S. GPM	L/M	PSI 800 BAR 55	PSI 1000 BAR 70	PSI 1200 BAR 85	
2530, 2531	25	95	13.7	17.1	N/A	1025
	21	80	11.5	14.4	17.3	860
2537	21	80	11.5	14.4	17.3	860
	18	68	9.9	12.3	14.8	738
	15	57	8.2	10.3	12.4	615

DETERMINING THE PUMP R.P.M. $\frac{\text{Rated G.P.M.}}{\text{Rated R.P.M.}}$ = $\frac{\text{"Desired" G.P.M.}}{\text{"Desired" R.P.M.}}$

DETERMINING THE REQUIRED H.P. $\frac{\text{GPM} \times \text{PSI}}{1460}$ = Electric Brake H. P. Required

DETERMINING MOTOR PULLEY SIZE $\frac{\text{Motor Pulley O.D.}}{\text{Pump R.P.M.}}$ = $\frac{\text{Pump Pulley O.D.}}{\text{Motor R.P.M.}}$

See complete Drive Packages [Incls: Pulleys, Belts, Hubs, Key] Tech Bulletin 003.
 Refer to pump **Service Manual** for repair procedure, additional technical information and **pump warranty**.

⚠ WARNING

All systems require both a primary pressure regulating device (i.e., regulator, unloader) and a secondary pressure safety relief device (i.e., pop-off valve, safety valve). Failure to install such relief devices could result in personal injury or damage to the pump or to system components. CAT PUMPS does not assume any liability or responsibility for the operation of a customer's high pressure system.

"Customer confidence is our greatest asset"

PARTS LIST

ITEM	PART NUMBER		PART NUMBER		PART NUMBER		DESCRIPTION	QTY
	2530	MATL	2531	MATL	2537	MATL		
2	990036	STL	990036	STL	990036	STL	Key (M8x7x40) [2/00]	1
5	92508	STZP	125753	S	125753	S	Screw, HHC, Sems (M8x25)	8
	126544	STCP R	—	—	—	—	Screw, HHC, Sems (M8x25)	8
8	27773	AL	27773	AL	27773	AL	Cover, Bearing	2
10	27772	NBR	27772	NBR	27772	NBR	O-Ring, Oil Seal Case - 70D	2
11	27771	NBR	27771	NBR	27771	NBR	Seal, Oil, Crankshaft - 70D	2
15	26512	STL	26512	STL	26512	STL	Bearing, Ball	2
20	48613	TNM	48613	TNM	48613	TNM	Rod, Connecting	3
21	48533	STZP	48533	STZP	48533	STZP	Washer, Locking	3
	126562	STCP R	126562	STCP R	126562	STCP R	Washer, Locking	3
25	48704	FCM	48704	FCM	48704	FCM	Crankshaft - Dual End [2/00]	1
31	828710	—	828710	—	828710	—	Protector, Oil Cap w/Gasket	1
32	43211	ABS	43211	ABS	43211	ABS	Cap, Oil Filler	1
33	14177	NBR	14177	NBR	14177	NBR	O-Ring, Oil Filler Cap -70D	1
38	11338	NBR	11338	NBR	11338	NBR	O-Ring, Dipstick - 70D	1
39	27769	ABS	27769	ABS	27769	ABS	Dipstick	1
40	92508	STZP	125753	S	125753	S	Screw, HHC, Sems (M8x25)	8
	126544	STCP R	—	—	—	—	Screw, HHC, Sems (M8x25)	8
48	25625	STCP	25625	STCP	25625	STCP	Plug, Drain (1/4"x19BSP)	1
49	23170	NBR	23170	NBR	23170	NBR	O-Ring, Drain Plug - 70D	1
50	27768	AL	27768	AL	27768	AL	Cover, Rear	1
51	27767	NBR	27767	NBR	27767	NBR	O-Ring, Rear Cover - 70D	1
53	27762	AL	27762	AL	27762	AL	Crankcase w/Guide Pins	1
54	27488	S	27488	S	27488	S	Pin, Guide	2
56	27790	POP	27790	POP	27790	POP	Pan, Oil	1
59	92519	STZP	92538	S	92538	S	Screw, HHC, Sems (M6x16)	2
	125824	STCP R	—	—	—	—	Screw, HHC, Sems (M6x16)	2
64	27784	CM	27784	CM	27784	CM	Pin, Crosshead	3
65	† 48592	SSHS	48592	SSHS	48592	SSHS	Rod, Plunger	3
70	27785	NBR	27785	NBR	27785	NBR	Seal, Crankcase Oil -70D	3
75	110669	S	110669	S	110669	S	Slinger, Barrier	3
88	110670	S	110670	S	110670	S	Washer, Keyhole	3
90	45749	CC	45749	CC	45749	CC	Plunger (M32x93)	3
95	† 89835	SSL	89835	SSL	89835	SSL	Stud, Retainer (M7x71)	3
96	20184	PTFE	20184	PTFE	20184	PTFE	Back-up-Ring, Plunger Retainer	3
97	14190	NBR	14190	NBR	14190	NBR	O-Ring, Plunger Retainer - 70D	3
	14161	FPM	14161	FPM	14161	FPM	O-Ring, Plunger Retainer - 70D	3
	◆ 48239	EPDM	◆ 48239	EPDM	◆ 48239	EPDM	O-Ring, Plunger Retainer	3
98	44069	SSL	44069	SSL	44069	SSL	Gasket, Plunger Retainer	3
99	44068	SSL	44068	SSL	44068	SSL	Retainer, Plunger [7/02]	3
100	110672	NY	110672	NY	110672	NY	Retainer, LPS, Front	3
	111116	NY	111116	NY	111116	NY	Retainer, LPS, Rear	3
101	110796	—	110796	—	110796	—	Wick, Long Tab (M32)	3
106	† 44098	NBR	44098	NBR	44098	NBR	Seal, LPS w/SS-Spg	3
	44827	FPM	44827	FPM	44827	FPM	Seal, LPS w/SS-Spg	3
	◆ 48244	EPDM	◆ 48244	EPDM	◆ 48244	EPDM	Seal, LPS w/SS-Spg	3
110	49265	CFBB	48583	SSL	45830	NAB	Manifold, Inlet	1
116	126570	STCP R	19085	S	19085	S	Lockwasher, Split	4
117	89822	STZP	88398	S	88398	S	Screw, HSH (M12x40)	4
	126518	STCP R	—	—	—	—	Screw, HSH (M12x40)	4
125	† 45832	SNG	45832	SNG	45832	SNG	Seal, HPS w/SS	3
	48220	STG*	48220	STG*	48220	STG*	Seal, HPS w/SS, 2-PC w/S-Support	3
143	14203	NBR	14203	NBR	14203	NBR	O-Ring, Adapter, LPS, Rear	3
	11731	FPM	11731	FPM	11731	FPM	O-Ring, Adapter, LPS, Rear	3
	◆ 48241	EPDM	◆ 48241	EPDM	◆ 48241	EPDM	O-Ring, Adapter, LPS, Rear	3
150	45752	BB	45835	SSL	45835	SSL	Adapter, LPS	3
154	18690	NBR	18690	NBR	18690	NBR	O-Ring, Adapter, LPS, Front - 70D	3
	11744	FPM	11744	FPM	11744	FPM	O-Ring, Adapter, LPS, Front	3
	◆ 48242	EPDM	◆ 48242	EPDM	◆ 48242	EPDM	O-Ring, Adapter, LPS, Front	3
155	14520	NBR	14520	NBR	14520	NBR	O-Ring, Adapter, Valve	6
	11745	FPM	11745	FPM	11745	FPM	O-Ring, Adapter, Valve	6
	◆ 48240	EPDM	◆ 48240	EPDM	◆ 48240	EPDM	O-Ring, Adapter, Valve	6
157	45751	BB	45834	SS	45834	SS	Adapter, Valve	3
164	† 46857	SSL	46857	SSL	46857	SSL	Seat [1/96]	6
165	14014	NBR	14014	NBR	14014	NBR	O-Ring, Seat	6
	48238	FPM	48238	FPM	48238	FPM	O-Ring, Seat	6
	◆ 48243	EPDM	◆ 48243	EPDM	◆ 48243	EPDM	O-Ring, Seat	6
166	45839	SSL	45839	SSL	45839	SSL	Valve	6
167	† 45840	SS	45840	SS	45840	SS	Spring	6
168	110682	PVDF	110682	PVDF	110682	PVDF	Retainer, Spring	6
185	49267	CFBB	48585	SSL	45836	NAB	Manifold, Discharge	1
186	126570	STCP R	19085	S	19085	S	Lockwasher, Split	8
188	89573	STCP	89628	S	89628	S	Screw, HSH (M12x65)	8
	126517	STCP R	—	—	—	—	Screw, HSH (M12x65)	8
250	26516	STCP	26516	STCP	26516	STCP	Protector, Shaft	1
260	30614	STZP	30614	STZP	30614	STZP	Rail, Angle Assy	1
269	30206	F	30206	F	30206	F	Pulley (10") [See Drive Packages, Tech Bulletin 003]	1
270	30059	STL	30059	STL	30059	STL	Hub, "H", M30 (Keyway M8) [See Drive Packages, Tech Bulletin 003] [2/00]	1
279	30278	STZP	30278	STZP	30278	STZP	Oilers (1 oz.)	3
281	30967	—	30967	—	30967	—	Glass, Oiler	3
282	10069	NBR	10069	NBR	10069	NBR	Gasket, Oiler	3

EXPLODED VIEW

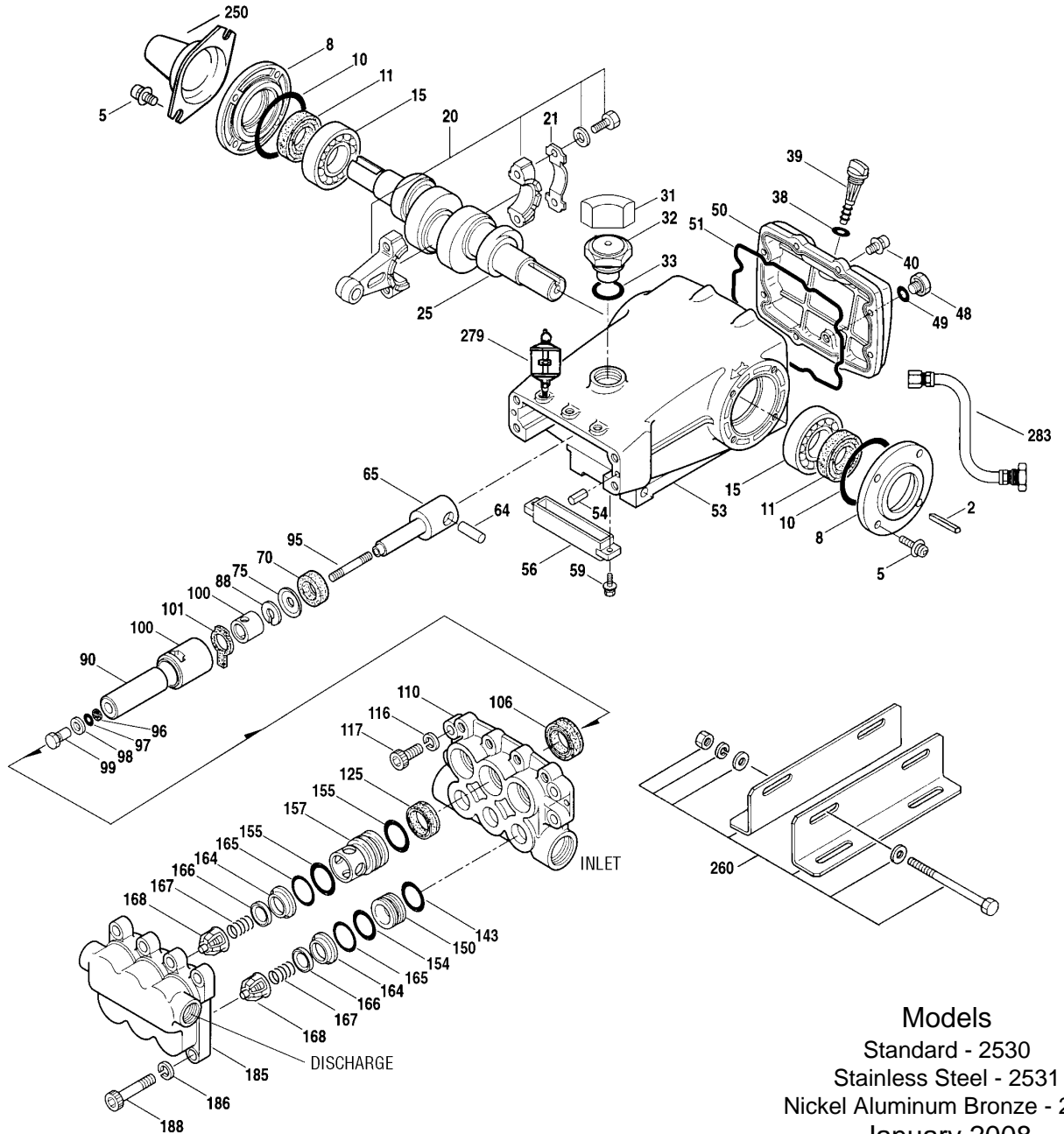

Models
 Standard - 2530
 Stainless Steel - 2531
 Nickel Aluminum Bronze - 2537
 January 2008

	2530	MATL	2531	MATL	2537	MATL		
283	34334	—	34334	—	34334	—	Kit, Oil Drain	1
290	6124	—	6124	—	6124	—	Gasket, Liquid (3 oz.)	1
299	814838	BB	816735	SS	816538	NAB	Head, Complete	1
300	30952	NBR	30952	NBR	30952	NBR	Kit, Seal (Incls: 97,106,125,143,154,155)	1
	33607	FPM*	33607	FPM*	33607	FPM*	Kit, Seal (Incls: 97,106,125,143,154,155)	1
	♦ 33608	EPDM*	♦ 33608	EPDM*	♦ 33608	EPDM*	Kit, Seal (Incls: 97,106,125,143,154,155)	1
310	33952	NBR	33952	NBR	33952	NBR	Kit, Valve (Incls: 143,154,155,164,165,166,167,168) [Prior to 11/95 6 Req.][1/96]	2
	31267	FPM	31267	FPM	31267	FPM	Kit, Valve (Incls: 143,154,155,164,165,166,167,168) [Prior to 11/95 6 Req.][1/96]	2
	♦ 31268	EPDM	♦ 31268	EPDM	♦ 31268	EPDM	Kit, Valve (Incls: 143,154,155,164,165,166,167,168) [Prior to 11/95 6 Req.][1/96]	2
390	714500	SS	714500	SS	714500	SS	C.A.T. (inlet pressure stabilizer for RO and boosted inlet applications)	1
391	714505	SS	714505	SS	714505	SS	Adapter (2 per C.A.T.) (See Data Sheet for complete selection)	2
—	6575	—	6575	—	6575	—	Plunger Pump Servicing DVD	1
—	6100	—	6100	—	6100	—	Oil, Case (12 Bottles) ISO 68 Multi-viscosity Hydraulic (Fill to specified crankcase capacity prior to start-up)	1
—	—	—	6119	—	—	—	Lubricant, Antiseize (1 oz.)	1

Bold print part numbers are unique to a particular pump model. Italics are optional items. [] Date of latest production change.

♦ Silicone oil/grease required. † Production parts are different than service parts. R Components comply with RoHS Directive.

*Review material codes for individual items (STG generally may be used as alternate).

See Tech Bulletins 002, 003, 024, 036, 043, 053, 074, 076, 077, 081, 083, 085 and 095 for additional information.

MATERIAL CODES (Not Part of Part Number): ABS=ABS Plastic AL=Aluminum BB=Brass CC=Ceramic CFBB=Chrome Forged Brass CM=Chrome-moly
 EPDM=Ethylene Propylene Diene Monomer F=Cast Iron FCM=Forged Chrome-moly FPM=Fluorocarbon NAB=Nickel Aluminum Bronze
 NBR=Medium Nitrile (Buna-N) NY=Nylon POP=Polypropylene PTFE=Pure Polytetrafluoroethylene PVDF=Polyvinylidene Fluoride S=304SS SS=316SS
 SNG=Special Blend (Buna) SSL=316SS/Low Carbon STG=Special Blend PTFE White STL=Steel SSHS=316SS/High Strength
 STCP=Steel/Chrome Plated STZP=Steel/Zinc Plated TNM=Special High Strength

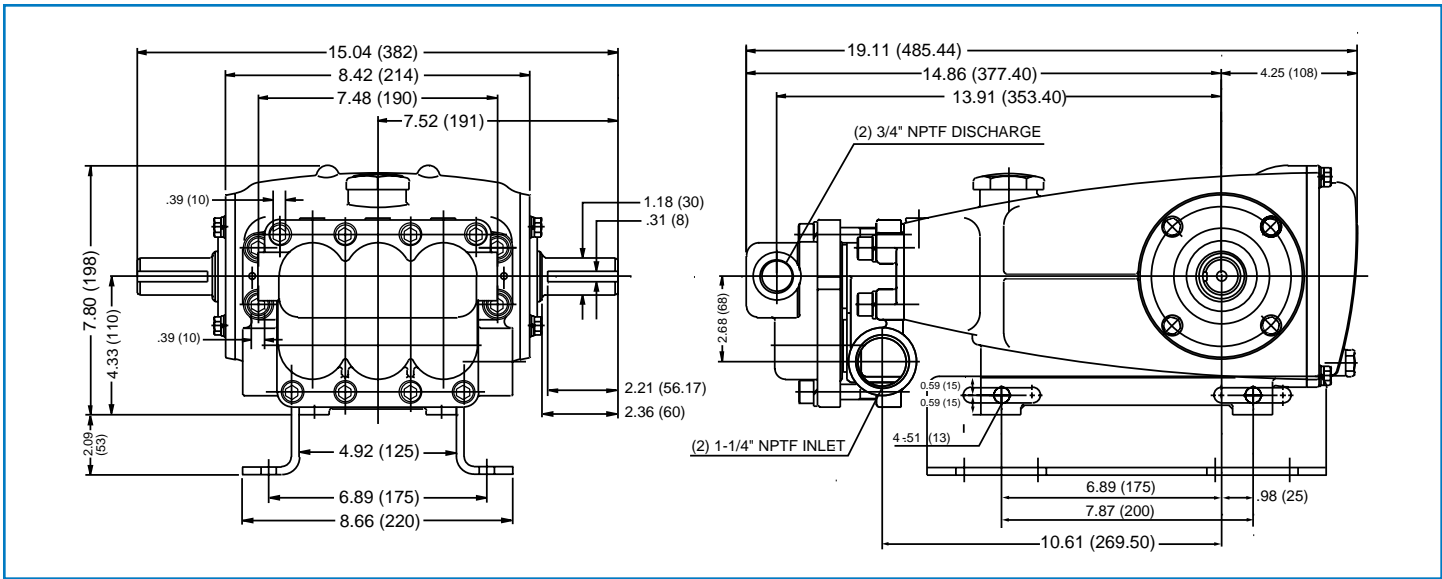

Models 2530, 2531, 2537



- 1 Die cast aluminum **crankcase** means high strength, light weight, and excellent tolerance control.
- 2 **Dipstick** offers top access for easy oil level check.
- 3 Oversized crankshaft **bearings** provide extended bearing life and pump performance.
- 4 Chrome-moly **crankshaft** provides unmatched strength and surface hardness for long life.
- 5 Matched oversized TNM **connecting rods** noted for superior tensile strength and bearing quality.
- 6 Special stainless steel **plunger rods** with high tensile strength crossheads for long life.
- 7 The stainless steel **slinger** provides back-up protection for the crankcase seal, keeping pumped liquids out of the crankcase.
- 8 Special concentric, high-density, polished, solid ceramic **plungers** provide a true wear surface and extended seal life.
- 9 **Manifolds** are a high tensile strength brass, 316 stainless steel or nickel aluminum bronze for long term, continuous duty.
- 10 100% wet **seal** design adds to service life by allowing pumped liquids to cool and lubricate on both sides.
- 11 Stainless steel **valves, seats and springs** provide corrosion-resistance, ultimate seating and extended life.
- 12 Specially formulated, CAT PUMP exclusive, **Hi-Pressure Seals** offer unmatched performance and seal life.
- 13 **Crosshead** is 360° supported for uncompromising alignment.

Products described hereon are covered by one or more of the following U.S. patents 3558244, 3652188, 3809508, 3920356, 3930756 and 5035580

World Headquarters
CAT PUMPS
 1681 - 94th Lane N.E. Minneapolis, MN 55449-4324
 Phone (763) 780-5440 — FAX (763) 780-2958
 e-mail: techsupport@catpumps.com
 www.catpumps.com

International Inquiries
 FAX (763) 785-4329
 e-mail: intlsales@catpumps.com



CAT PUMPS (U.K.) LTD.
 1 Fleet Business Park, Sandy Lane, Church Crookham
 FLEET, Hampshire, GU52 8BF, England
 Phone Fleet 44 1252-622031 — Fax 44 1252-626655
 e-mail: sales@catpumps.co.uk

N.V. CAT PUMPS INTERNATIONAL S.A.
 Heiveldekens 6A, B-2550 Kontich, Belgium
 Phone 32-3-450.71.50 — Fax 32-3-450.71.51
 e-mail: cpi@catpumps.be www.catpumps.be

CAT PUMPS DEUTSCHLAND GmbH
 Buchwiese 2, D-65510 Idstein, Germany
 Phone 49 6126-9303 0 — Fax 49 6126-9303 33
 e-mail: catpumps@t-online.de www.catpumps.de