

## Direct-Drive Plunger Pumps

Model

2SF

### PUMP FEATURES

- Triplex design provides smoother liquid flow.
- Unique spring loaded inlet valves and the flow through ceramic plungers provides a smooth, steady flow.
- Ultimate portability—less than 11 pounds—less than 10" long.
- Standard shaft pump for direct mounting to gas engine or electric motor or special SOLID SHAFT for belt-drive.
- Optional 3450 or 1725 RPM models.
- Regulating Unloader is standard on each pump to assure system pressure control and pump protection.
- Special Hi-Temp seal option for pumping 190°F water.
- Optional Thermo Valve mounts directly into by-pass hose for optimum heat protection while in by-pass.

### COMMON PUMP SPECIFICATIONS

Inlet Pressure Range.....(Standard)	Flooded to 75 PSI	(Flooded to 5.25 BAR)
.....(Hi-Temp)	30 to 75 PSI	(2.1 to 5.25 BAR)
Bore.....	0.708"	(18 mm)
Max. Liquid Temperature...(Standard)	160°F	(71°C)
.....(Hi-Temp)	190°F	(88°C)
Above 130°F call CAT PUMPS for inlet conditions and elastomer recommendations.		
Crankcase Capacity.....	11.83 oz.	(.35 L)
Inlet Ports (1).....	3/8" NPTF	(3/8" NPTF)
Discharge Ports (2).....	3/8" NPTF	(3/8" NPTF)
By-Pass Ports (1).....	1/4" NPTF	(1/4" NPTF)
Weight (Pump Only).....	10.6 lbs.	(4.8 kg)
Dimensions (Pump Only).....	9.13 x 6.65 x 6.50"	(232 x 169 x 165mm)

#### **⚠ WARNING**

All systems require both a primary pressure regulating device (i.e., regulator, unloader) and a secondary pressure safety relief device (i.e., pop-off valve, safety valve). Failure to install such relief devices could result in personal injury or damage to the pump or to system components. CAT PUMPS does not assume any liability or responsibility for the operation of a customer's high pressure system.

### SPECIFICATIONS

	U.S. Measure	Metric Measure	U.S. Measure	Metric Measure
<b>MODEL</b>			<b>2SF10ES</b>	
Flow.....			1.0 GPM	(3.8 L/M)
Max. Discharge Pressure.....			2000 PSI	(140 BAR)
Max. RPM.....			3450 RPM	(3450 RPM)
Stroke.....			0.067"	(1.7 mm)
<b>MODEL</b>			<b>2SF20ES</b>	<b>2SF22ES</b>
Flow.....	2.0 GPM	(7.6 L/M)	2.2 GPM	(8.3 L/M)
Max. Discharge Pressure	2000 PSI	(140 BAR)	2000 PSI	(140 BAR)
Max. RPM.....	3450 RPM	(3450 RPM)	3450 RPM	(3450 RPM)
Stroke.....	0.122"	(3.1 mm)	0.132"	(3.35 mm)
<b>MODEL</b>			<b>2SF22ELS</b>	<b>2SF22SLS</b>
Flow.....	2.2 GPM	(8.3 L/M)	2.2 GPM	(8.3 L/M)
Max. Discharge Pressure	<b>2000 PSI</b>	<b>(140 BAR)</b>	2000 PSI	(140 BAR)
Max. RPM.....	<b>1725 RPM</b>	<b>(1725 RPM)</b>	<b>1725 RPM</b>	<b>(1725 RPM)</b>
Stroke.....	0.248"	(6.3 mm)	0.248"	(6.3 mm)
<b>MODEL</b>			<b>2SF29ELS</b>	<b>2SF30ES</b>
Flow.....	2.85 GPM	(10.8 L/M)	3.0 GPM	(11.4 L/M)
Max. Discharge Pressure	<b>1500 PSI</b>	<b>(105 BAR)</b>	1500 PSI	(105 BAR)
Max. RPM.....	<b>1725 RPM</b>	<b>(1725 RPM)</b>	3450 RPM	(3450 RPM)
Stroke.....	0.335"	(8.5 mm)	0.177"	(4.5 mm)
<b>MODEL</b>			<b>2SF30GS</b>	
Flow.....			3.0 GPM	(11.4 L/M)
Max. Discharge Pressure.....			<b>2000 PSI</b>	<b>(140 BAR)</b>
Max. RPM.....			3450 RPM	(3450 RPM)
Stroke.....			0.189"	(4.8 mm)
<b>MODEL</b>			<b>2SF35ES</b>	<b>2SF35GS</b>
Flow.....	3.5 GPM	(13.2 L/M)	3.5 GPM	(13.2 L/M)
Max. Discharge Pressure	1500 PSI	(105 BAR)	<b>2000 PSI</b>	<b>(140 BAR)</b>
Max. RPM.....	3450 RPM	(3450 RPM)	3450 RPM	(3450 RPM)
Stroke.....	0.220"	(5.6 mm)	0.220"	(5.6 mm)
	Optional Electric-3/4" Shaft - 2SF30GES, 2SF35GES			

ES, ELS = **Electric 5/8"** hollow shaft with bolt mount

GES = **Electric 3/4"** hollow shaft with bolt mount

GS = **Gas 3/4"** hollow shaft with bolt and adapter mount

SLS = **Electric 3/4"** solid shaft complete with bracket mount.

Refer to pump **Service Manual** for repair procedure, additional technical information and **pump warranty**.

*"Customer confidence is our greatest asset"*

# EXPLODED VIEW

September 2008

# SF PLUNGER PUMP MODELS

2SF10, 2SF20, 2SF22, 2SF29, 2SF30, 2SF35

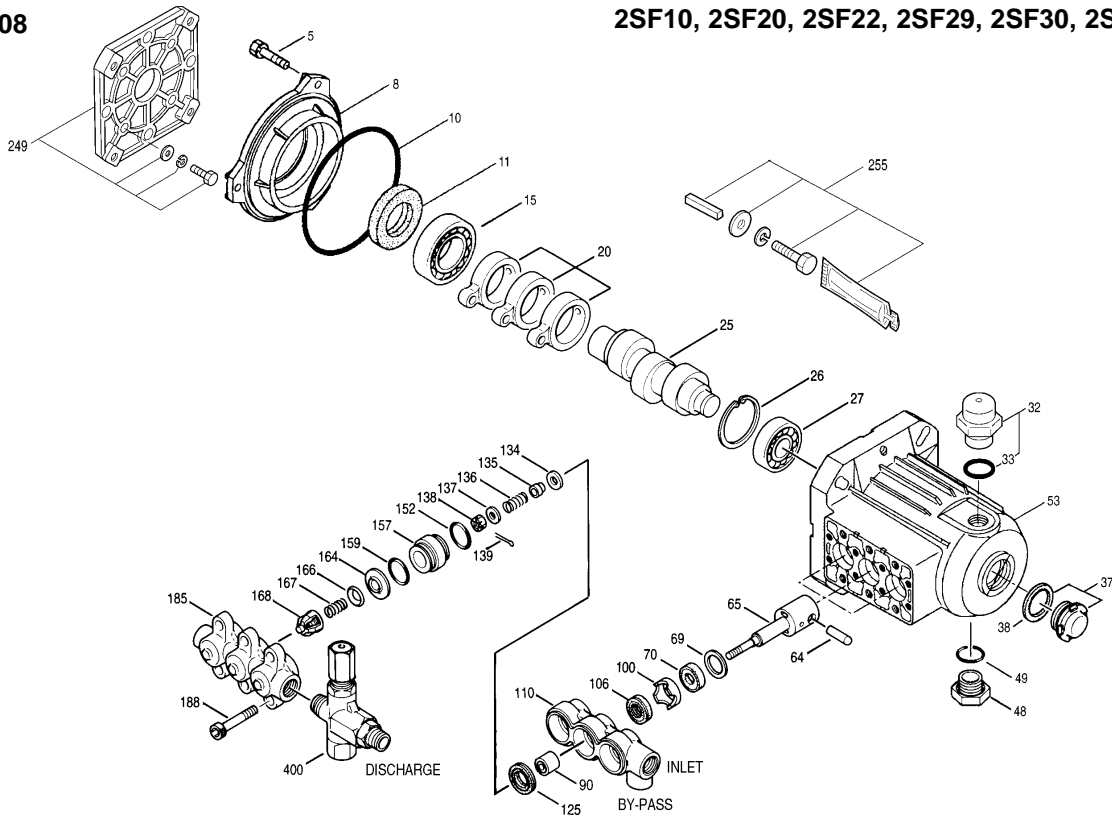

## PARTS LIST

ITEM	P/N	MATL	DESCRIPTION	MODEL USED	QTY	ITEM	P/N	MATL	DESCRIPTION	MODEL USED	QTY
5	547161	STCP	Screw, HH (M6x14)	All Models	3	136	44872	S	Spring, Inlet Valve	All Models	3
	<i>549360</i>	<i>STCP R</i>	<i>Screw, HH (M6x 14)</i>	<i>All Models</i>	<i>3</i>	137	88575	S	Washer, Conical (M6)	All Models	3
8	547153	AL	Cover, Bearing, Inner [3/03]	All Models	1	138	27000	S	Nut, Slotted (M6)	All Models	3
10	14041	NBR	O-Ring, Bearing Cover - 70D [3/03]	All Models	1	139	14158	S	Cotterpin (M1.6x10)	All Models	3
11	55337	NBR	Seal, Oil [3/03]	All Models	1	152	26089	NBR	O-Ring, Adapter, Inner - 80D	All Models	3
15	14488	STL	Bearing, Ball, Inner	All Models	1	<i>11377</i>	<i>FPM</i>	<i>O-Ring, Adapter, Inner - 80D</i>	<i>All Models</i>	<i>3</i>	
20	547046	TNM	Rod, Connecting	All Models	3	157	44878	BB	Discharge Valve Adapter	All Models except 29ELS	3
25	543135	FCM	Crankshaft, 3450 RPM, 5/8", 1.7mm	10ES	1	45430	BB	Discharge Valve Adapter	29ELS	3	
	46109	FCM	Crankshaft, 3450 RPM, 5/8", 3.1mm	20ES	1	159	26089	NBR	O-Ring, Adapter, Outer - 80D	All Models	3
	46074	FCM	Crankshaft, 3450 RPM, 3/4", 3.35mm	22GS	1	<i>11377</i>	<i>FPM</i>	<i>O-Ring, Adapter, Inner - 80D</i>	<i>All Models</i>	<i>3</i>	
	44929	FCM	Crankshaft, 3450 RPM, 5/8", 3.35mm	22ES	1	164	44881	S	Seat	All Models	3
546334	FCM	Crankshaft, 3450 RPM, 3/4", 4.8mm	30GS	1	166	43723	S	Valve	All Models	3	
44931	FCM	Crankshaft, 3450 RPM, 5/8", 4.5mm	30ES	1	167	541062	S	Spring	All Models	3	
45096	FCM	Crankshaft, 3450 RPM, 5/8", 5.6mm	35ES	1	168	44565	PVDF	Retainer, Spring	All Models	3	
46017	FCM	Crankshaft, 3450 RPM, 3/4", 5.6mm	35GS	1	185	44879	BB	Manifold, Discharge	All Models	1	
45160	FCM	Crankshaft, <b>1725 RPM</b> , 5/8", 6.3mm	22ELS	1	188	87859	STZP	Screw, HSH (M8x75)	All Models	6	
45426	FCM	Crankshaft, <b>1725 RPM</b> , 5/8", 8.5mm	29ELS	1	<i>126762</i>	<i>STCP R</i>	<i>Screw, HSH (M8x75)</i>	<i>All Models</i>	<i>6</i>		
45146	FCM	Crankshaft, <b>1725 RPM, Solid</b> , 3/4", 6.3mm	22SL	1	249	30520	Assy, Adapter Mount, Gas	30G, 35G	1		
26	12385	STL	Ring, Retaining	All Models	1	46271	AL	Flange		1	
27	15710	STL	Bearing, Ball, Outer	All Models	1	549351	STCP R	Screw, HH (5/16-24x20)		4	
32	547961	RTP	Cap, Oil Filler w/O-Ring	All Models	1	15845	STZP	Lockwasher (M8)		4	
33	14179	NBR	O-Ring, Oil Filler Cap - 70D	All Models	1	<i>126232</i>	<i>STCP R</i>	<i>Lockwasher (M8)</i>		<i>4</i>	
37	92241	—	Gauge, Bubble Oil w/Gasket - 80D	All Models	1	126573	STCP R	Washer, Flat (M8)		4	
38	44428	NBR	Gasket, Flat Flex., Oil Gauge - 80D	All Models	1	255	30517	STZP	Assy, Bolt Mount	All Models	1
48	44842	NY	Plug, Drain (1/2" NPT)	All Models	1	127024	STZP R	Washer, Flat (3/8")		4	
49	14179	NBR	O-Ring, Drain Plug - 70D	All Models	1	127025	STZP R	Lockwasher, Split (3/8")		4	
53	547285	AL	Crankcase [3/03]	All Models	1	126543	STCP R	Screw, HH (3/8"-16 x 1-3/8")		4	
64	16948	CM	Pin, Crosshead	All Models	3	6106	—	Lubricant, Antiseize		1	
65	44865	SCP	Rod, Plunger	All Models except 29ELS	3	30050	STL	Key (3/16" x 3/16" x 1-1/4" HD)		1	
	45427	SZZ	Rod, Plunger	29ELS	3	259	30973	STZP	Kit, Mounting Bracket (Incl. w/Pump)	22SL	1
69	126259	STCP R	Washer (M24)	All Models	3			(Incls: Bracket, Washers, Bolts, Nuts)			
70	25461	NBR	Seal, Oil	All Models	3	285	80228	STL	Screw (M8-1.25x80) (Not Shown)	All Models	2
90	45847	CC	Plunger (M18x14)	All Models except 29ELS	3	300	34053	NBR	Kit, Seal (Incls: 106,125,139,152,159)	All Models	1
	45429	CC	Plunger (M18x16)	29ELS	3	33953	HT	Kit, Seal - Hi-Temp (Incls: 106,125,134,139,152,159)	All Models	1	
100	44869	PVDF	Retainer, Seal	All Models	3	33453	FPM	Kit, Seal (Incls: 106,125,139,152,159)	All Models	1	
106	44876	NBR	Seal, LPS w/S-Spg	All Models	3	310	34052	NBR	Kit, Valve (Incls: 152,159,164,166,167,168)	All Models	1
	<i>545192</i>	<i>FPM</i>	<i>Seal, LPS w/SS-Spg</i>	<i>All Models</i>	<i>3</i>	311	34668	NBR	Kit, Inlet Valve (Incls: 134-137,139,152,159)	All Models	1
110	44874	BB	Manifold, Inlet	All Models	1	352	44050	STZP	Tool, Oil Gauge Removal	All Models	1
125	43245	SNG	Seal, HPS w/S	All Models	3	400	75005	BB	Unloader, Regulating	All Models	1
	46652	HT	Seal, HPS "Hi-Temp" 2-Pc w/S-Support	All Models	3	—	36086	—	Assembly, Pulsator	All Models	1
134	45854	S	Valve, Inlet	All Models	3	—	6575	—	Plunger Pump Service DVD	All Models	1
	<i>33873</i>	<i>NY</i>	<i>Valve, Inlet, Hi-Temp</i>	<i>All Models</i>	<i>3</i>	—	6107	—	Oil, Bottle (21 oz) ISO 68 Multi-Viscosity Hydraulic	All Models	1
135	549520	S	Spacer, Inlet	All Models	3			(Fill to specified crankcase capacity prior to start-up)			

**Bold print part numbers are unique to a particular pump model. Italics are optional items.** [ ] Date of latest production change. R Components comply with RoHS Directive.

See Tech Bulletins 002, 024, 036, 043, 055, 060, 064, 065, 070, 073, 074, 083, 091 and 092 for additional information.

NOTE: Discard Key which may come standard with most motors and engines and use **only the key included in this kit.**

MATERIAL CODES (Not Part of Part Number): AL=Aluminum BB=Brass CC=Ceramic CM=Chrome-Moly FCM=Forged Chrome-moly FPM=Fluorocarbon

HT=Hi-Temp (EPDM Alternative) NBR=Medium Nitrile (Buna-N) NY=Nylon PVDF=Polyvinylidene Fluoride RTP=Reinforced Composite

S=304SS SCP=304SS/Chrome Plated SNG=Special Blend (Buna) STL=Steel STCP=Steel/Chrome Plated STZP=Steel/Zinc Plated SZZ=304SS/Zamak TNM=Special High Strength

Center raised pilot guide on the **Adapter Plate** assures proper alignment of pump and engine. Before mounting pump onto engine inspect engine for **recessed seal and bearing guide** to permit adapter to completely seat into recess and four bosses to be flush with engine face.

## UNLOADER SPECIFICATIONS

MODEL 7500S	U.S. Measure	Metric Measure
GPM .....	0.5-6.0 GPM	(2-23 L/M)
PSI .....	100-2000 PSI	(7-140 BAR)
Inlet Port - Rear .....	3/8" NPTM	(3/8" NPTM)
Discharge Port - Front .....	M18 x 1.0	(M18 x 1.0)
By-pass Port - Bottom .....	3/8" NPTF	(3/8" NPTF)
Weight .....	14 oz.	(0.43 kg)
Dimensions .....	3.0 x 1.0 x 4.25"	(76 x 25 x 108 mm)

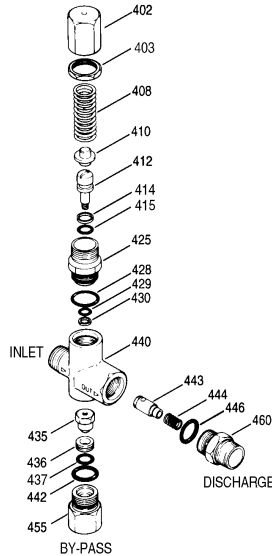

ITEM	P/N	MATL	DESCRIPTION	QTY.
402	540081	BB	Cap, Hex Adjusting	1
403	31047	BB	Nut, Lock (M18 x 1)	1
408	32094	STZP R	Spring, Pressure	1
410	107672	BB	Retainer, Spring	1
412	45694	S	Stem, Piston (M5)	1
414	20184	PTFE	Back-up-Ring, Piston Stem	1
415	14190	NBR	O-Ring, Piston Stem - 70D	1
	14161	FPM	O-Ring, Piston Stem - 70D	1
425	107673	BB	Retainer, Piston	1
428	13969	NBR	O-Ring, Piston Retainer - 70D	1
	14320	FPM	O-Ring, Piston Retainer - 70D	1
429	14759	NBR	O-Ring, Body	1
	14160	FPM	O-Ring, Body - 70D	1
430	107675	PTFE	Back-up-Ring, Body	1
435	45696	BB	Valve and Ball Assembly (M5)	1
436	107680	S	Seat	1
437	13963	NBR	O-Ring, Seat - 70D	1
	14303	FPM	O-Ring, Seat - 70D	1
440	—	BB	Body	1
442	13969	NBR	O-Ring, By-Pass Fitting - 70D	1
	14320	FPM	O-Ring, By-Pass Fitting - 70D	1
443	541060	BB	Valve, Check w/O-Ring	1
444	45924	S	Spring	1
446	13969	NBR	O-Ring, Discharge Fitting - 70D	1
	14320	FPM	O-Ring, Discharge Fitting - 70D	1
455	45695	BB	Fitting, By-Pass (3/8" NPTF)	1
460	107681	BB	Fitting, Discharge (3/8" NPTM)	1
465	7090	BB	By-Pass Hose (15" x 3/8")	1
466	7090.40	BB	By-Pass Hose w/Thermo Valve	1
468	32097	NBR	Kit, O-Ring (Incls: 414,415, 428, 429, 430, 437, 442, 446)	1
	31627	FPM	Kit, O-Ring (Incls: 414,415, 428, 429, 430, 437, 442, 446)	1
485	7140	BB	Valve, Thermo	1
486	—	BB	Tee, T.V. Mount	1
487	—	BB	Nipple, T.V. Mount	1

*Italics are optional items. R Components comply with RoHS Directive.*

MATERIAL CODES (Not Part of Part Number): BB=Brass FPM=Fluorocarbon  
NBR=Medium Nitrile (Buna-N) PTFE=Pure Polytetrafluoroethylene S=304SS  
STZP=Steel/Zinc Plated

## UNLOADER TYPE

A regulating unloader comes with each 2SF plunger pump to provide system pressure regulation and pump protection. Optional adjustable chemical injectors for chemical application can be purchased.

## OPERATION

Pump should be purged of air before commencing with operation. Liquid must flow through the pump without discharge restriction to assure full system pressure is reached.

Install a pressure gauge close to the manifold head of the pump to assist in setting system pressure and to periodically monitor system pressure. By-pass line can be directed to the ground, or to a reservoir or be redirected to the 1/4" NPTF port on bottom side of inlet manifold. If routing to pump inlet use a 3/8" flexible hose and thermo valve.

**NOTE:** If not using a thermo valve **DO NOT EXCEED 6 MINUTES** in by-pass.

## CHEMICAL INJECTOR SPECIFICATIONS

MODEL	Standard	Optional
Flow .....	7193 3-4 GPM	7194 4-5 GPM
Nozzle Orifice .....	2.1mm	2.3mm
Hose Barb .....	1/4"	1/4"
Inlet Port .....	M18 x 1.0	M18 x 1.0
Discharge Port .....	3/8" NPTM	3/8" NPTM
Weight .....	6.3 oz.	6.3 oz.
Dimensions .....	2 x 1 x 3"	2 x 1 x 3"

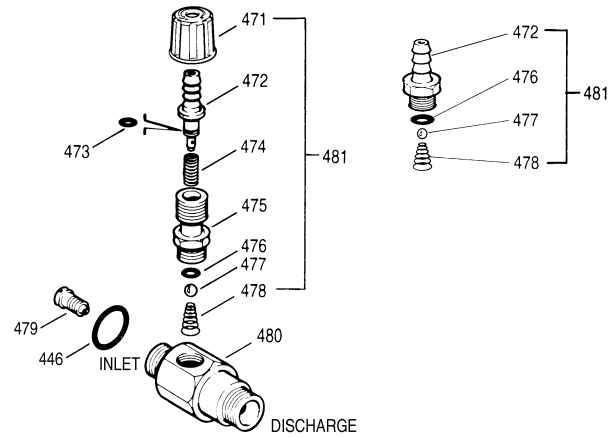

ITEM	P/N	MATL	DESCRIPTION	QTY.
446	13969	NBR	O-Ring, Body - 70D	1
	14320	FPM	O-Ring, Body - 70D	1
471	33949	NY	Handle, Adjustable	1
472	32941	BB	Barb, Adjustable	1
	33505	BB	Barb, Fixed	1
473	—	NBR	O-Ring, Hose Barb	1
474	33500	S	Spring	1
475	33946	BB	Retainer, Ball Seat	1
476	33504	FPM	O-Ring, Retainer	1
477	34620	SS	Ball	1
478	33501	SS	Spring, Tapered	1
479	32373	S	Orifice, Injector (2.1mm) Standard	1
	32374	S	Orifice, Injector (2.3mm)	1
480	—	BB	Body	1
481	33481	BBNY	Barb, Assy, Adjustable	1
			(Incls: 471, 472, 473, 474, 475, 476, 477, 478)	
—	33480	BB	Barb, Assy, Fixed (Incls: 472, 476, 477, 478)	1

*Italics are optional items.*

MATERIAL CODES (Not Part of Part Number): BB=Brass FPM=Fluorocarbon  
NBR=Medium Nitrile (Buna-N) NY=Nylon S=304SS SS=316SS

CHEMICAL INJECTOR PERFORMANCE CHART				
Optional Special Ported Chemical Injector for Unloader Mounting				
Standard Pump Model	Injector Orifice Size	Lo-Pressure Nozzle Rating (Maximum Downstream) (Press for Injector)	Max. Chem. Draw (0 PSI) (Downstream)	Hi-Press Nozzle "Deduction" (Press. drop across Inj.)
2SF20	2.1 mm (7193)	100 PSI	50 oz/min	100 PSI
2SF22	2.1 mm (7193)	75 PSI	50 oz/min	100 PSI
2SF29, 2SF30	2.1 mm (7193)	225 PSI	50 oz/min	150 PSI
2SF35	2.3 mm (7194)	150 PSI	50 oz/min	150 PSI

Optimum performance of chemical injector occurs with a 35 ft. high pressure hose and a minimum 3/8" I.D. The type of hose, extended lengths, reduced I.D. and fittings may create back pressures in excess of the low pressure nozzle rating and prevent the injector from drawing chemical. Deduct hose friction loss from above low PSI Nozzle. Contact CAT PUMPS for assistance with other options. Refer to Hose Friction Loss Chart in the Service Manual for pressure loss with longer hose.

**NOTE:** For Hi-Temp seal pumps **DO NOT USE THERMO VALVE**, use optional dual pressure switches and mechanical relays.

Setting and adjusting the unloader pressure must be done with the system turned on. Start the system with the unloader backed off to the lowest pressure setting (counterclockwise direction). Squeeze the trigger and read the pressure on the gauge at the pump. Do not read pressure at the gun or nozzle. If more pressure is desired, release the trigger, turn adjusting cap one quarter turn in a clockwise direction. Squeeze the trigger and read the pressure. Repeat this process until the desired system pressure is reached. Thread locking nut up to adjusting cap.

**NOTE:** Pressure is not set at the factory.

## SERVICE

The unloader should be serviced on the same schedule as the seals in the pump. Refer to SF Plunger Pump Service Manual for start-up, servicing of seals and valves, torque requirements and diagnosis and maintenance chart.

# MOTOR SPECIFICATIONS

**Model 8050**

Horsepower .....	1.5
Shaft Diameter.....	5/8"
Max. Volts.....	<b>115/230</b>
FULL LOAD AMPS.....	12.1
RPM.....	3450
Weight.....	32.1 lbs.
Phase.....	Single
Frame Size.....	56-C TEFC
Service Factor.....	1.15

**Model 8052**

Horsepower .....	2.0
Shaft Diameter.....	5/8"
Max. Volts.....	<b>115/230</b>
FULL LOAD AMPS.....	17.0/9.2-8.5
RPM.....	3450
Weight.....	32.5 lbs.
Phase.....	Single
Frame Size.....	56-C TEFC
Hertz.....	60
Service Factor.....	1.15

**Model 8055**

Horsepower .....	3.0
Shaft Diameter.....	● 3/4"
Max. Volts.....	<b>230</b>
FULL LOAD AMPS.....	15.2/13.6
RPM.....	3450
Weight.....	46.3 lbs.
Phase.....	Single
Frame Size.....	56-C TEFC
Service Factor.....	1.15

**Model 8057**

Horsepower .....	5.0
Shaft Diameter.....	● 3/4"
Max. Volts.....	<b>230</b>
FULL LOAD AMPS.....	22.0
RPM.....	3450
Weight.....	40 lbs.
Phase.....	Single
Frame Size.....	56-C OPEN DRIP
Service Factor.....	1.15

**\* Model 8060**

Horsepower .....	1.5
Shaft Diameter.....	5/8"
Max. Volts.....	<b>115/230</b>
FULL LOAD AMPS.....	14.0/7.0
RPM.....	<b>1725</b>
Weight.....	40 lbs.
Phase.....	Single
Frame Size.....	56-C TEFC
Service Factor.....	1.2

**\* Model 8062**

Horsepower .....	2.0
Shaft Diameter.....	5/8"
Max. Volts.....	<b>115/230</b>
FULL LOAD AMPS.....	17.0/8.5
RPM.....	<b>1725</b>
Weight.....	43.7 lbs.
Phase.....	Single
Frame Size.....	56-C TEFC
Service Factor.....	1.15

**Common Motor Specifications**

Max. Ambient Temp.....	104°F
Capacitor Start .....	Yes
Thermal Overload-Manual Reset .....	Yes
U.L. Construction Reference .....	
(8050,8055).....	E49747
(8052, 8057, 8060, 8062) .....	E44549
U.L. Insulation Reference (All) ...	E37878
CSA Reference .....	
(8050) .....	LR45148
(8052, 8057, 8060, 8062).....	LR4642
(8055).....	LR2025

● Use 3/4" shaft size motor with GES Pumps.

\* Use with ELS models or to reduce flow by 50% on standard models.

\* Use with ELS models or to reduce flow by 50% on standard models.

Note: Motor Start-Up AMPS may vary, then settle within FULL LOAD AMPS rating after initial run in time.  
 ★ ★ Before mounting pump on motor, apply P.N. 6106 Antiseize Lubricant to pump shaft.  
 ★ ★ Refer to Tech Bulletin 055 for instructions on removing pump from gas engine or electric motor.  
 Add .050 for 50 Hz (1450 or 2850 RPM)

For warranty consideration contact CAT PUMPS for the local **Authorized Service Center**. If you are uncertain as to the cause of failure (Pump or Motor), secure **Returned Goods Authorization number** and return complete assembly **PREPAID** to CAT PUMPS for evaluation.

## ELECTRIC HORSEPOWER REQUIREMENTS

FLOW		PRESSURE					PUMP RPM
		PSI 700	PSI 1000	PSI 1200	PSI 1500	PSI 2000	
U.S. GPM	Metric L/M	BAR 50	BAR 70	BAR 85	BAR 105	BAR 140	
1.0	3.8	.48	.69	.82	1.0	1.4	3450
2.2	8.3	1.1	1.5	1.8	2.3	3.0	3450
2.85	10.8	1.36	2.0	2.3	2.9	N/A	1725
3.0	11.4	1.4	2.1	2.5	3.1	4.1	3450
3.5	13.2	1.7	2.4	2.9	3.6	N/A	3450

## DETERMINING THE REQUIRED H.P.

$$\frac{\text{GPM} \times \text{PSI}}{1460} = \text{Electric Brake H.P. Required}$$

## 2SF DIMENSIONAL DRAWING

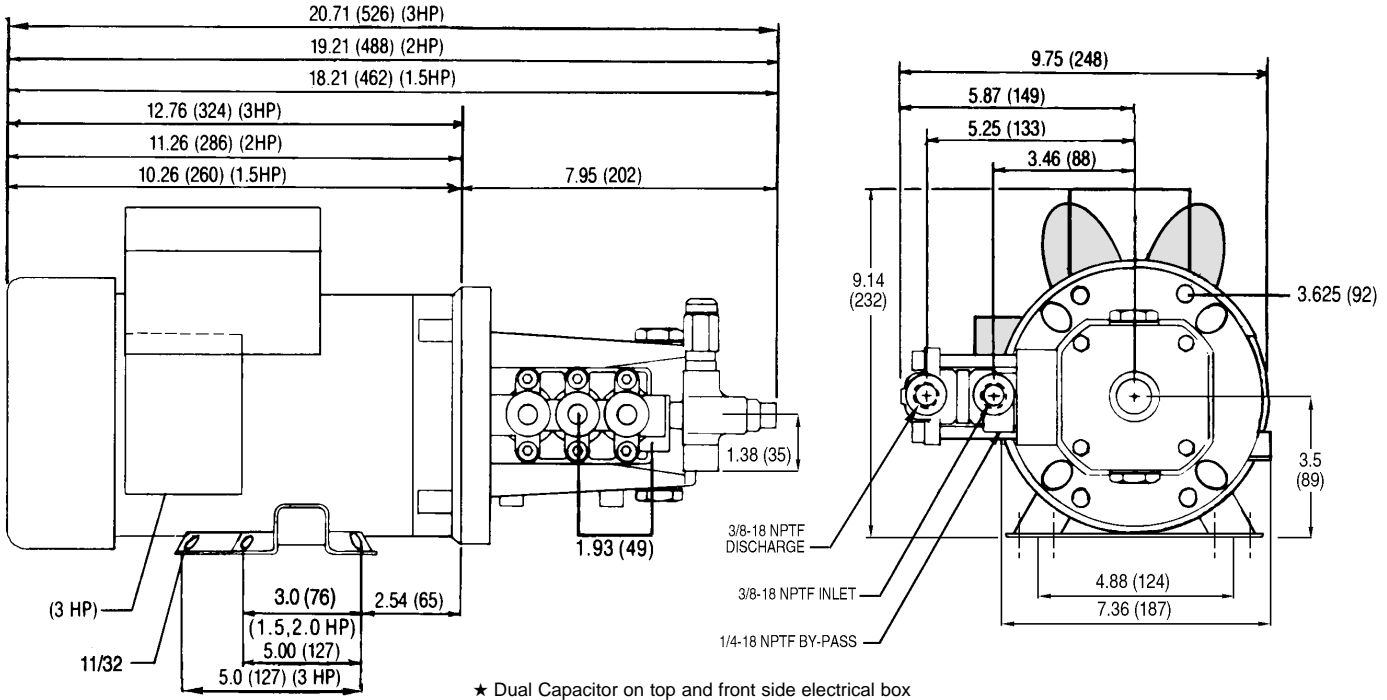

Products described hereon are covered by one or more of the following U.S. patents 3558244, 3652188, 3809508, 3920356, 3930756 and 5035580

**World Headquarters**  
**CAT PUMPS**  
 1681 - 94th Lane N.E. Minneapolis, MN 55449-4324  
 Phone (763) 780-5440 — FAX (763) 780-2958  
 e-mail: techsupport@catpumps.com  
 www.catpumps.com



**CAT PUMPS (U.K.) LTD.**  
 1 Fleet Business Park, Sandy Lane, Church Crookham  
 FLEET, Hampshire, GU52 8BF, England  
 Phone Fleet 44 1252-622031 — Fax 44 1252-626655  
 e-mail: sales@catpumps.co.uk www.catpumps.co.uk

**N.V. CAT PUMPS INTERNATIONAL S.A.**  
 Heiveldekens 6A, B-2550 Kontich, Belgium  
 Phone 32-3-450.71.50 — Fax 32-3-450.71.51  
 e-mail: cpi@catpumps.be www.catpumps.be

**CAT PUMPS DEUTSCHLAND GmbH**  
 Buchwiese 2, D-65510 Idstein, Germany  
 Phone 49 6126-9303 0 — Fax 49 6126-9303 33  
 e-mail: catpumps@t-online.de www.catpumps.de

**International Inquiries**  
 FAX (763) 785-4329  
 e-mail: intlsales@catpumps.com