

PARTS LIST

ITEM	PART NUMBER		DESCRIPTION	QTY
	310	310S		
	340	340S		
	350 MATL	350S MATL		
2	30057 STL	30057 STL	Key (M6x6x25)	1
5	92519 STZP	92519 STZP	Screw, HHC, Sems (M6x16)	8
	125824 STCP R	125824 STCP R	Screw, HHC, Sems (M6x16)	8
8	43344 AL	43344 AL	Cover, Bearing	1/2
10	43343 NBR	43343 NBR	O-Ring, Bearing Cover - 70D	2
11	43222 NBR	43222 NBR	Seal, Oil, Crankshaft - (310, 350-2) (340-1)	1/2
15	14480 STL	14480 STL	Bearing, Ball	2
20	45883 HS	45883 HS	Rod, Connecting Assy [09/05]	3
25	43342 FCM	43342 FCM	Crankshaft, Dual End - 310, 310S	1
	44945 FCM	44945 FCM	Crankshaft, Single End - 340, 340S	1
	43838 FCM	43838 FCM	Crankshaft, Dual End - 350, 350S	1
30	44949 AL	44949 AL	Cover, Blind Shaft - 340	1
31	828710 —	828710 —	Protector, Oil Cap w/Foam Gasket	1
32	43211 ABS	43211 ABS	Cap, Oil Filler	1
33	14177 NBR	14177 NBR	O-Ring, Filler Cap - 70D	1
37	92241 —	92241 —	Gauge, Oil, Bubble w/Gasket	1
38	44428 NBR	44428 NBR	Gasket, Flat, Oil Gauge - 80D	1
40	92520 STZP	92520 STZP	Screw, HHC, Sems (M6x20)	4
	126541 STCP R	126541 STCP R	Screw, HHC, Sems (M6x20)	4
48	25625 STCP	25625 STCP	Plug, Drain (1/4"x19 BSP)	1
49	23170 NBR	23170 NBR	O-Ring, Drain Plug - 70D	1
50	48772 AL	48772 AL	Cover, Rear [10/01]	1
51	48773 NBR	48773 NBR	O-Ring, Rear Cover [10/01]	1
53	48769 AL	48769 AL	Crankcase [05/02]	1
56	43355 POP	43355 POP	Pan, Oil	1
64	43351 CM	43351 CM	Pin, Crosshead	3
65	43365 ZZCP	43365 ZZCP	Rod, Plunger	3
70	43228 NBR	43228 NBR	Seal, Oil, Crankcase	3
75	43328 S	43328 S	Slinger, Barrier	3
88	45697 S	45697 S	Washer, Keyhole (M18)	3
90	43367 CC	43367 CC	Plunger (M20x72)	3
96	43235 PTFE	43235 PTFE	Back-up-Ring, Plunger Retainer	3
97	17399 NBR	17399 NBR	O-Ring, Plunger Retainer - 80D	3
	14160 FPM	14160 FPM	O-Ring, Plunger Retainer - 70D	3
	◆ 46204 EPDM	◆ 46204 EPDM	O-Ring, Plunger Retainer - 70D	3
98	45891 CU	45891 CU	Gasket	3
99	104360 S	104360 S	Retainer, Plunger w/Stud	3
100	45688 PVDF	45688 PVDF	Retainer, Seal, 2-Pc [04/06]	3
101	43302 —	43302 —	Wick, Long Tab	3
106	43305 NBR	43305 NBR	Seal, LPS w/S-Spg	3
	45153 FPM	45153 FPM	Seal, LPS w/SS-Spg	3
	◆ 48429 EPDM	◆ 48429 EPDM	Seal, LPS w/SS-Spg	3
120	45679 BB	45679 BB	Case, Seal	3
121	14200 NBR	14200 NBR	O-Ring, Seal Case - 70D	3
	11719 FPM	11719 FPM	O-Ring, Seal Case	3
	◆ 48907 EPDM	◆ 48907 EPDM	O-Ring, Seal Case	3
125	43307 SNG	43307 SNG	Seal, HPS w/S	3
	44936 FPM	44936 FPM	Seal, HPS w/SS	3
	46667 HT*	46667 HT*	Seal, HPS "Hi-Temp", 2-Pc w/S-Support	3
139	22179 BBCP	22179 BBCP	Plug, Inlet (1/2" NPT)	1
162	48361 D	48361 D	Back-up-Ring, Seat	6
163	43358 NBR	43358 NBR	O-Ring, Seat - 70D	6
	44938 FPM	44938 FPM	O-Ring, Seat - 70D	6
	◆ 48908 EPDM	◆ 48908 EPDM	O-Ring, Seat	6
164	43725 S	43725 S	Seat	6
166	43723 S	43723 S	Valve	6
167	43750 S	43750 S	Spring, Valve	6
168	44565 PVDF	44565 PVDF	Retainer, Valve Spring	6
172	17615 NBR	17615 NBR	O-Ring, Valve Plug - 75D	6
	15855 FPM	15855 FPM	O-Ring, Valve Plug -70D	6
	◆ 48431 EPDM	◆ 48431 EPDM	O-Ring, Valve Plug -75D	6
174	43849 BBCP	43849 BBCP	Plug, Valve	6
185	44837 BBCP	—	Head, Manifold	1
	—	46278 FBB	Head, Manifold, Sleeved	1
188	126520 STCP R	126520 STCP R	Screw, HSH, Sems (M10x35)	2
250	118672 STCP	118672 STCP	Protector, Shaft (Belt Drive Only)	1
255	30243 STZP	30243 STZP	Mount, Direct (Belt Drive Only)	1
260	30611 STZP	30611 STZP	Mounting, Angle Rail (Belt Drive Only)	1
265	30659 —	30659 —	Mount, Assy (Incls: 30611, 30633, 118672) (Belt Drive Only)	1
270	30633 STL	30633 STL	Assy, Pulley & Key (Incls: 30058, 30057) (Belt Drive Only)	1
275	30944 STL	30944 STL	Assy, Hub & Key (Incls: 30057, 30945) (Belt Drive Only)	1
283	34334 —	34334 —	Kit, Oil Drain (3/8" x 24")	1
298	34962 STZP	34962 STZP	Clutch Assy, Single Groove, 20mm, 12VDC	1
	34963 STZP	34963 STZP	Clutch Assy, Dual Groove, 20mm, 12VDC	1
299	810027 BBCP	816551 FBB	Head, Complete	1

EXPLODED VIEW

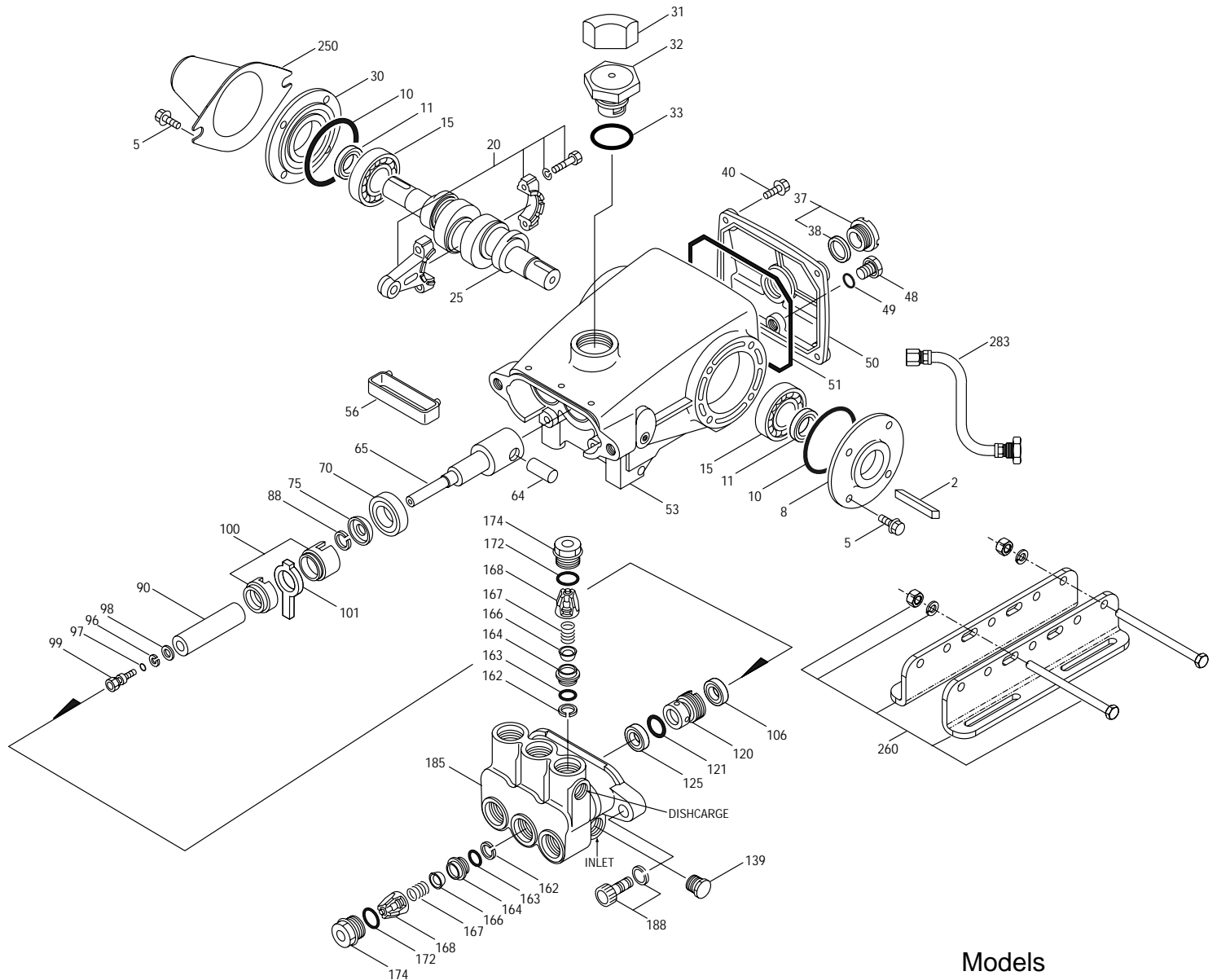

Models
 Standard - 310, 340, 350
 Sleeved - 310S, 340S, 350S
 February 2009

	310	340	350	MATL	310S	340S	350S	MATL		
300	30623	34155	33623	NBR	30623	34155	33623	NBR	Kit, Seal (Incls: 97,101,106,121,125)	1
		34155	33623	FPM	34155	34155	33623	FPM	Kit, Seal (Incls: 97,101,106,121,125)	1
			33623	HT	33623		33623	HT	Kit, Seal, "Hi-Temp" (Incls: 97,101,106,121,125)	1
	◆		31163	EPDM*	◆		31163	EPDM*	Kit, Seal (Incls: 97,101,106,121,125)	1
310			30821	NBR	30821		30821	NBR	Kit, Valve, Preassembled (Incls: 162-164,166-168,172)	2
			31821	FPM	31821		31821	FPM	Kit, Valve, Preassembled (Incls: 162-164,166-168,172)	2
	◆		31162	EPDM	◆		31162	EPDM	Kit, Valve, Preassembled (Incls: 162-164,166-168,172)	2
350			30696	STZP			30696	STZP	Plier, Reverse	1
351			33004	STZP			33004	STZP	Socket, Seal Case (1/2" Drive)	1
—			—	—			—	—	BD Motors - See Individual Data Sheet	
—			6107	—			6107	—	Oil, Bottle (21 oz.) ISO-68 Hydraulic	1
									(Fill to specified crankcase capacity prior to start-up)	

Bold print part numbers are unique to a particular pump model. Italics are optional items. ◆Silicone oil/grease required. R Components comply with RoHS Directive.
 [] Date of latest production change. *Review individual parts in each kit for material code identification.
 See Tech Bulletins 002, 003, 008, 024, 027, 032, 035, 036, 043, 045, 046, 049, 052, 053, 054, 073, 074, 077, 079, 083, 090, 105 and 106 for additional information.
 MATERIAL CODES (Not Part of Part Number): ABS=ABS Plastic AL=Aluminum BB=Brass BBCP=Brass/Chrome Plated CC=Ceramic CM=Chrome-moly CU=Copper
 D=Acetal EPDM=Ethylene Propylene Diene Monomer FBB=Forged Brass FCM=Forged Chrome-moly FPM=Fluorocarbon HS=High Strength
 HT=High Temp (EPDM Alternative) NBR=Medium Nitrile (Buna-N) POP=Polypropylene PTFE=Pure Polytetrafluoroethylene PVDF=Polyvinylidene Fluoride
 S=304SS SNG=Special Blend (Buna) STL=Steel STCP=Steel/Chrome Plated STZP=Steel/Zinc Plated ZZCP=Chrome Plated/Steel - Zamak

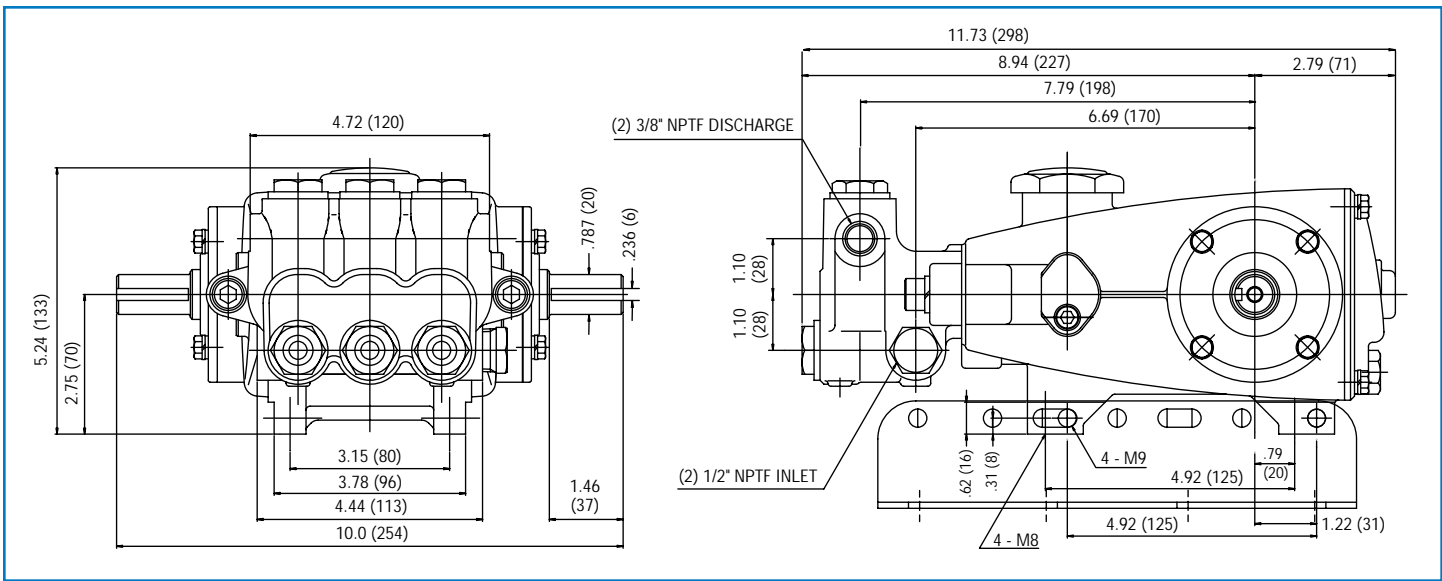

Models 310, 340, 350, 310S, 340S, 350S

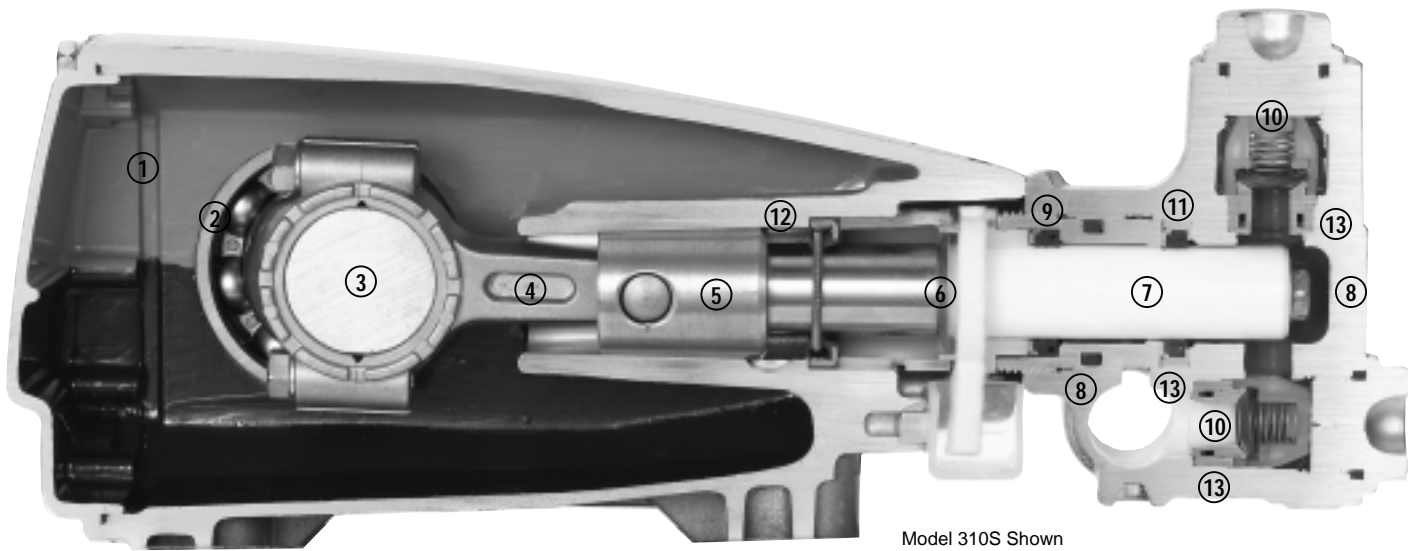

Model 310S Shown

- | | | |
|--|--|---|
| <p>1 Die cast aluminum crankcase means high strength, lightweight, and excellent tolerance control.</p> <p>2 Oversized crankshaft bearings provide extended bearing life and pump performance.</p> <p>3 Chrome-moly crankshaft provides unmatched strength and surface hardness for long life.</p> <p>4 Matched oversized high strength connecting rods noted for superior tensile strength and bearing quality.</p> <p>5 High strength plunger rods for high load bearing and longevity.</p> | <p>6 The stainless steel slinger provides back-up protection for the crankcase seal, keeping pumped liquids out of the crankcase.</p> <p>7 Special concentric, high-density, polished, solid ceramic plungers provide a true wear surface and extended seal life.</p> <p>8 Manifolds are a high tensile strength forged brass for long life, continuous duty and compatibility.</p> <p>9 100% wet seal design adds to service life by allowing pumped liquids to cool and lubricate on both sides.</p> | <p>10 Stainless steel valves, seats and springs provide corrosion-resistance, ultimate seating and extended life.</p> <p>11 Specially formulated, CAT PUMP exclusive, Hi-Pressure Seals offer unmatched performance and seal life.</p> <p>12 Crossheads are 360° supported for uncompromising alignment.</p> <p>13 Precision, press-fit, 304 stainless steel sleeves in both the seal and valve chambers provide extended life (S models only).</p> |
|--|--|---|

Products described hereon are covered by one or more of the following U.S. patents 3558244, 3652188, 3809508, 3920356, 3930756 and 5035580

World Headquarters
CAT PUMPS
 1681 - 94th Lane N.E. Minneapolis, MN 55449-4324
 Phone (763) 780-5440 — FAX (763) 780-2958
 e-mail: techsupport@catpumps.com
 www.catpumps.com

International Inquiries
 FAX (763) 785-4329
 e-mail: intlsales@catpumps.com



CAT PUMPS (U.K.) LTD.
 1 Fleet Business Park, Sandy Lane, Church Crookham
 FLEET, Hampshire, GU52 8BF, England
 Phone Fleet 44 1252-622031 — Fax 44 1252-626655
 e-mail: sales@catpumps.co.uk www.catpumps.co.uk

N.V. CAT PUMPS INTERNATIONAL S.A.
 Heiveldekens 6A, B-2550 Kontich, Belgium
 Phone 32-3-450.71.50 — Fax 32-3-450.71.51
 e-mail: cpi@catpumps.be www.catpumps.be

CAT PUMPS DEUTSCHLAND GmbH
 Buchwiese 2, D-65510 Idstein, Germany
 Phone 49 6126-9303 0 — Fax 49 6126-9303 33
 e-mail: catpumps@t-online.de www.catpumps.de