

Model 311 Shown

FEATURES

Superior Design

- Triplex plunger design gives smoother liquid flow.
- Hi-Pressure Seals are completely lubricated and cooled by the liquid being pumped.
- Inlet and discharge valve assemblies interchange for easier maintenance.
- Lubricated Lo-Pressure Seal provides double protection against external leakage.
- Oil bath crankcase assures optimum lubrication.
- Close tolerance concentricity of the ceramic plunger maximizes seal life.
- Convenient direct drive electric motor options.

Quality Materials

- Precision design 316 stainless steel valves and seats are hardened and polished for ultimate seating and extended valve life.
- 316 Stainless Steel or Nickel Aluminum Bronze manifolds for strength and corrosion resistance.
- Special concentric, high-density, polished, solid ceramic plungers provide a true wear surface and extended seal life.
- Specially formulated, CAT PUMP exclusive, Hi-Pressure Seals offer unmatched performance and seal life.
- Die cast aluminum crankcase provides high strength, minimum weight and precision tolerance control.
- Chrome-moly crankshaft gives unmatched strength and surface hardness.
- Oversized crankshaft bearings with greater loading capacity mean longer bearing life.

Easy Maintenance

- Wet-end is easily serviced without entering crankcase, requiring less time and effort.
- Valve assemblies are accessible without disturbing piping, for quick service.
- Preset packings mean no packing gland adjustment is necessary, reducing maintenance costs.

⚠ WARNING

All systems require both a primary pressure regulating device (i.e., regulator, unloader) and a secondary pressure safety relief device (i.e., pop-off valve, safety valve). Failure to install such relief devices could result in personal injury or damage to the pump or to system components. CAT PUMPS does not assume any liability or responsibility for the operation of a customer's high pressure system.

5 Frame Plunger Pump

Stainless Steel Models 311, 341, 351
Nickel Aluminum Bronze Models 317, 347, 357

SPECIFICATIONS

	U.S. Measure	Metric Measure
MODEL 311, 317		
Flow	4.0 GPM	(15 L/M)
Pressure Range	100 to 2200 PSI	(7 to 155 BAR)
RPM	950 RPM	(950 RPM)
Inlet Pressure Range	5 to 60 PSI	(-0.35 to 4 BAR)
Stroke	0.709"	(18 mm)
MODEL 341, 347 Direct Drive		
Flow	4.0 GPM	(15 L/M)
Pressure Range	100 to 1800 PSI	(7 to 125 BAR)
RPM	1725 RPM	(1725 RPM)
Inlet Pressure Range	Flooded to 60 PSI	(Flooded to 4 BAR)
Stroke	0.394"	(10 mm)
MODEL 351, 357 Direct Drive		
Flow*	5.0 GPM	(19 L/M)
Pressure Range	100 to 1500 PSI	(7 to 105 BAR)
RPM	1725 RPM	(1725 RPM)
Inlet Pressure Range	Flooded to 60 PSI	(Flooded to 4 BAR)
Stroke	0.472"	(12 mm)

*This specification for intermittent, fresh water duty.

COMMON SPECIFICATIONS

Bore	0.787"	(20 mm)
Crankcase Capacity	18 oz.	(0.55 L)
Maximum Liquid Temperature	160°F	(71°C)
Above 130°F call CAT PUMPS for inlet conditions and elastomer recommendations.		
Inlet Ports (2)	1/2" NPTF	(1/2" NPTF)
Discharge Ports (2)	3/8" NPTF	(3/8" NPTF)
Shaft Diameter	0.787"	(20 mm)
Weight	19.8 lbs.	(9 kg)
Dimensions	11.69 x 10.0 x 5.26"	(297x254 x 133.50 mm)

ELECTRIC HORSEPOWER REQUIREMENTS

MODEL	FLOW		PRESSURE					MOTOR PULLEY SIZE	
	U.S. GPM	L/M	PSI 1200	PSI 1500	PSI 1800	PSI 2000	PSI 2200	Using 1725 RPM Motor & Std. 8" Pump Pulley	
			BAR 85	BAR 105	BAR 125	BAR 140	BAR 155	RPM	Pulley O.D.
311, 317	5.0	19	4.1	5.1	N/A	N/A	N/A	1190	5.5
	4.0	15	3.3	4.1	5.0	5.5	6.0	950	4.4
	3.0	11.4	2.5	3.1	3.7	4.2	4.5	713	3.3
341, 347	4.0	15	3.3	4.1	5.0	N/A	N/A	1725	Direct Drive
351, 357	5.0	19	4.1	5.1	N/A	N/A	N/A	1725	Direct Drive

DETERMINING THE PUMP R.P.M. $\frac{\text{Rated G.P.M.}}{\text{Rated R.P.M.}}$ = "Desired" G.P.M. "Desired" R.P.M.

DETERMINING THE REQUIRED H.P. $\frac{\text{GPM} \times \text{PSI}}{1460}$ = Electric Brake H. P. Required

DETERMINING MOTOR PULLEY SIZE $\frac{\text{Motor Pulley O.D.}}{\text{Pump R.P.M.}}$ = $\frac{\text{Pump Pulley O.D.}}{\text{Motor R.P.M.}}$

See complete Drive Packages [Incls: Pulleys, Belts, Hubs, Key] Tech Bulletin 003.
 Refer to pump **Service Manual** for repair procedure, additional technical information and **pump warranty**.

"Customer confidence is our greatest asset"

PARTS LIST

ITEM	PART NUMBER		DESCRIPTION	QTY
	311	317		
	341	347		
	351	357		
	MATL	MATL		
2	30057 STL	30057 STL	Key (M6x6x25)	1
5	92538 S	92538 S	Screw, Sems HHC (M6x16)	8
8	43344 AL	43344 AL	Cover, Bearing	1/2
10	43343 NBR	43343 NBR	O-Ring, Bearing Cover	2
11	43222 NBR	43222 NBR	Seal, Oil, Crankshaft - (311, 351-2) (341-1)	1/2
15	14480 STL	14480 STL	Bearing, Ball	2
20	45883 HS	45883 HS	Rod, Connecting Assy [09/05]	3
25	43342 FCM	43342 FCM	Crankshaft, Dual End - 311, 317	1
	44945 FCM	44945 FCM	Crankshaft, Single End - 341, 347	1
	43838 FCM	43838 FCM	Crankshaft, Dual End - 351, 357	1
30	44949 AL	44949 AL	Cover, Blind Shaft - 341	1
31	828710 —	828710 —	Protector, Oil Cap w/Foam Gasket	1
32	43211 ABS	43211 ABS	Cap, Oil Filler	1
33	14177 NBR	14177 NBR	O-Ring, Filler Cap - 70D	1
37	92241 —	92241 —	Gauge, Oil, Bubble w/Gasket	1
38	44428 NBR	44428 NBR	Gasket, Flat, Oil Gauge - 80D	1
40	92542 S	92542 S	Screw, Sems HHC (M6x20)	4
48	25625 STCP	25625 STCP	Plug, Drain (1/4"x19 BSP)	1
49	23170 NBR	23170 NBR	O-Ring, Drain Plug - 70D	1
50	48772 AL	48772 AL	Cover, Rear [10/01]	1
51	48773 NBR	48773 NBR	O-Ring, Rear Cover [10/01]	1
53	48769 AL	48769 AL	Crankcase [05/02]	1
56	43355 POP	43355 POP	Pan, Oil	1
64	43351 CM	43351 CM	Pin, Crosshead	3
65	45256 SSZZ	45256 SSZZ	Rod, Plunger	3
70	43228 NBR	43228 NBR	Seal, Oil, Crankcase	3
75	43328 S	43328 S	Slinger, Barrier	3
88	45697 S	45697 S	Washer, Keyhole (M18)	3
90	43367 CC	43367 CC	Plunger (M20x72)	3
95	89653 SS	89653 SS	Stud, Plunger Retainer (M6x58)	3
96	43235 PTFE	43235 PTFE	Back-up-Ring, Plunger Retainer	3
97	17399 NBR	17399 NBR	O-Ring, Plunger Retainer - 80D	3
	14160 FPM	14160 FPM	O-Ring, Plunger Retainer - 70D	3
	◆ 46204 EPDM	◆ 46204 EPDM	O-Ring, Plunger Retainer - 70D	3
98	44041 SS	44041 SS	Gasket	3
99	44031 SS	44031 SS	Retainer, Plunger	3
100	45688 PVDF	45688 PVDF	Retainer, Seal 2-PC [04/06]	3
101	43302 —	43302 —	Wick, Long Tab	3
106	44127 NBR	44127 NBR	Seal, LPS w/SS-Spg	3
	45153 FPM	45153 FPM	Seal, LPS w/SS-Spg	3
	◆ 48429 EPDM	◆ 48429 EPDM	Seal, LPS w/SS-Spg	3
120	45680 SS	45680 SS	Case, Seal	3
121	14200 NBR	14200 NBR	O-Ring, Seal Case - 70D	3
	11719 FPM	11719 FPM	O-Ring, Seal Case - 70D	3
	◆ 48907 EPDM	◆ 48907 EPDM	O-Ring, Seal Case	3
125	44649 SNG	44649 SNG	Seal, HPS w/SS	3
	44936 FPM	44936 FPM	Seal, HPS w/SS	3
	46667 HT*	46667 HT*	Seal, HPS "Hi-Temp", 2-Pc w/S-Support	3
139	45156 SS	44563 NAB	Plug, Inlet (1/2" NPT)	1
162	48361 D	48361 D	Back-up-Ring, Seat	6
163	43358 NBR	43358 NBR	O-Ring, Seat - 70D	6
	44938 FPM	44938 FPM	O-Ring, Seat - 70D	6
	◆ 48908 EPDM	◆ 48908 EPDM	O-Ring, Seat	6
164	44128 SS	44128 SS	Seat	6
166	44057 SS	44057 SS	Valve	6
167	44056 SS	44056 SS	Spring, Valve	6
168	44565 PVDF	44565 PVDF	Retainer, Valve Spring	6
171	44832 S	44832 S	Spring, Coil	6
172	17615 NBR	17615 NBR	O-Ring, Valve Plug - 75D	6
	15855 FPM	15855 FPM	O-Ring, Valve Plug -70D	6
	◆ 48431 EPDM	◆ 48431 EPDM	O-Ring, Valve Plug -75D	6
174	49296 SS	44833 NAB	Plug, Valve [05/06]	6
185	45151 SSL	44124 NAB	Manifold Head	1
186	15847 S	15847 S	Lockwasher (M10)	2
188	87950 S	87950 S	Screw HSH (M10x35) [01/04]	2
250	118672 STCP	118672 STCP	Protector, Shaft (Belt Drive Only)	1
255	30243 STZP	30243 STZP	Mount, Direct (Belt Drive Only)	1
260	30611 STZP	30611 STZP	Mounting, Angle Rail - B (28499,30900,30910,30920) (Belt Drive Only)	1
265	30659 —	30659 —	Mount, Assy (30611,30633,118672) (Belt Drive Only)	1
270	30633 STL	30633 STL	Assy, Pulley & Key (30058,30057) (Belt Drive Only)	1
275	30944 STL	30944 STL	Assy, Hub & Key (M20 w/M6 Keyway) (Belt Drive Only)	1
			[See Drive Packages, Tech Bulletin 003]	
283	34334 —	34334 —	Kit, Oil Drain	1

EXPLODED VIEW

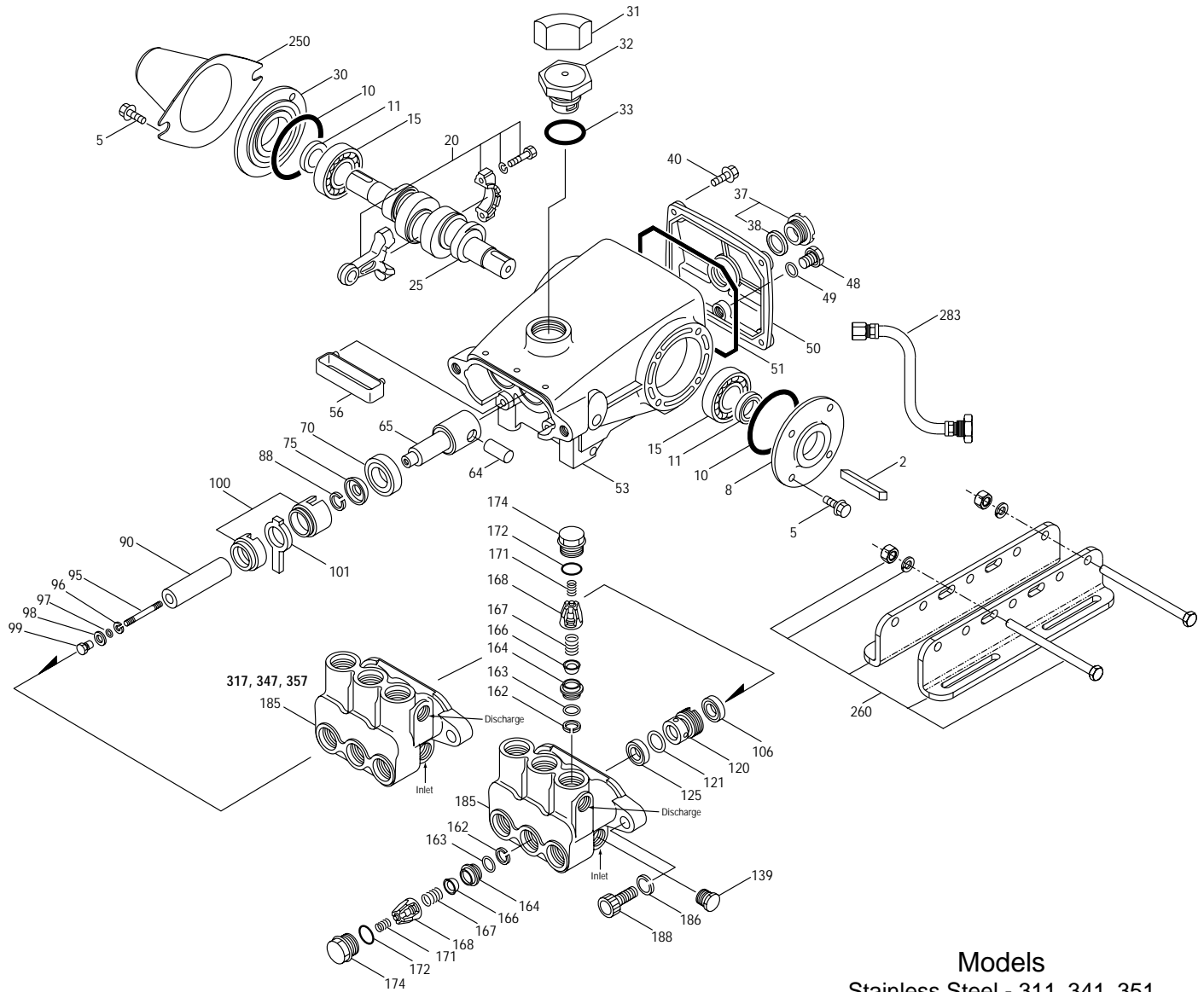

Models
 Stainless Steel - 311, 341, 351
 Nickel Aluminum Bronze - 317, 347, 357
 May 2006

	311	341	351	MATL	317	347	357	MATL		
298	34962	STZP	34962	STZP	Clutch Assy, Single Groove, 20mm, 12VDC	1				
	34963	STZP	34963	STZP	Clutch Assy, Dual Groove, 20mm, 12VDC	1				
299	812207	SS	814559	NAB	Head, Complete	1				
300	34153	NBR	34153	NBR	Kit, Seal (Incls: 97,101,106,121,125)	1				
	34155	FPM	34155	FPM	Kit, Seal (Incls: 97,101,106,121,125)	1				
	33623	HT	33623	HT	Kit, Seal, "Hi-Temp" (Incls: 97,101,106,121,125)	1				
	◆ 31163	EPDM*	◆ 31163	EPDM*	Kit, Seal (Incls: 97,101,106,121,125)	1				
310	31152	NBR	31152	NBR	Kit, Valve (Incls: 162-164,166-168,171,172)	2				
	34152	FPM	34152	FPM	Kit, Valve (Incls: 162-164,166-168,171,172)	2				
350	30696	STZP	30696	STZP	Plier, Reverse	1				
351	33004	STZP	33004	STZP	Socket, Seal Case (1/2" Drive)	1				
—	6107	—	6107	—	Oil, Bottle (21 oz.) ISO 68 Multi-viscosity Hydraulic (Fill to specified crankcase capacity prior to start-up)	1				
—	6119	—	—	—	Lubricant, Antiseize (1 oz.)	1				

Bold print part numbers are unique to a particular pump model. Italics are optional items. ◆ Silicone oil/grease required.

[] Date of latest production change. *Review material codes for individual items (HT generally may be used as alternate). Add .3000 to part numbers for Hi-Temp model. See Tech Bulletins 002, 003, 008, 024, 027, 032, 035, 036, 043, 045, 046, 049, 052, 053, 054, 073, 074, 077, 079, 083, 090 and 095 for additional information.
 MATERIAL CODES (Not Part of Part Number): ABS=ABS Plastic AL=Aluminum CC=Ceramic CM=Chrome-moly D=Acetal EPDM=Ethylene Propylene Diene Monomer FCM=Forged Chrome-moly FPM=Fluorocarbon HS=High Strength HT=High Temp (EPDM Alternative) NAB=Nickel Aluminum Bronze NBR=Medium Nitrile (Buna-N) POP=Polypropylene PTFE=Pure Polytetrafluoroethylene PVDF=Polyvinylidene Fluoride S=304SS SNG=Special Blend (Buna) SS=316SS SSL=316SS/Low Carbon SSZZ=316SS/Zamak STL=Steel STCP=Steel/Chrome Plated STZP=Steel/Zinc Plated

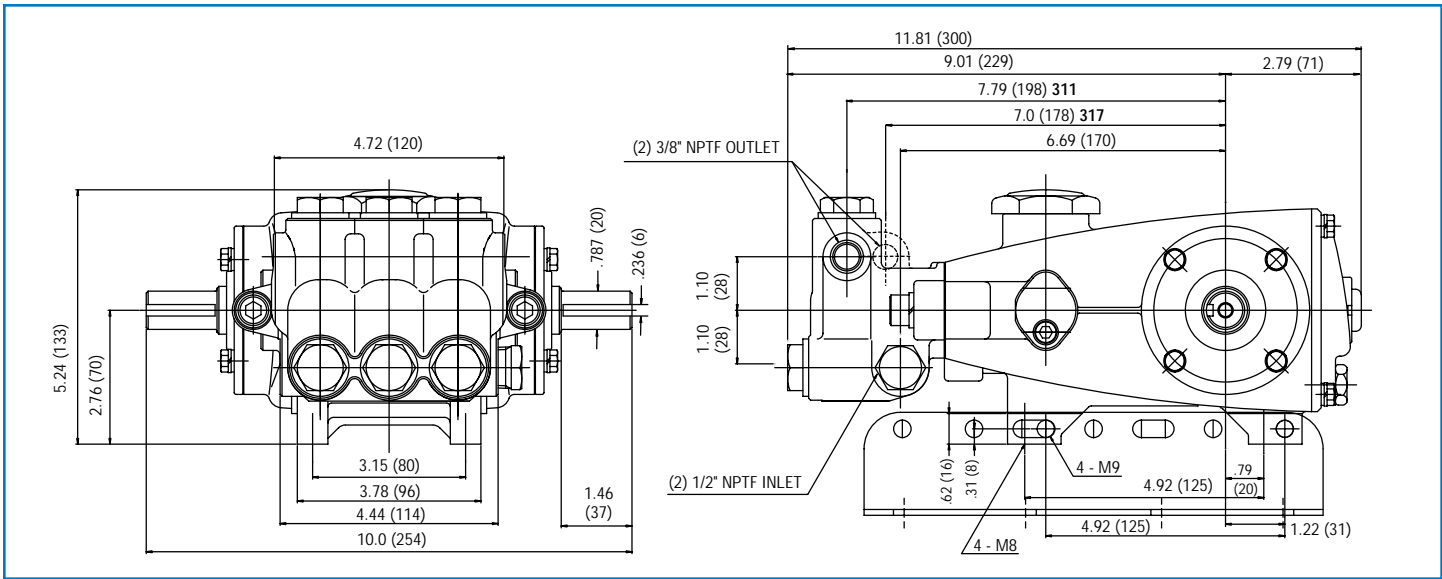

Models 311, 317, 341, 347, 351, 357

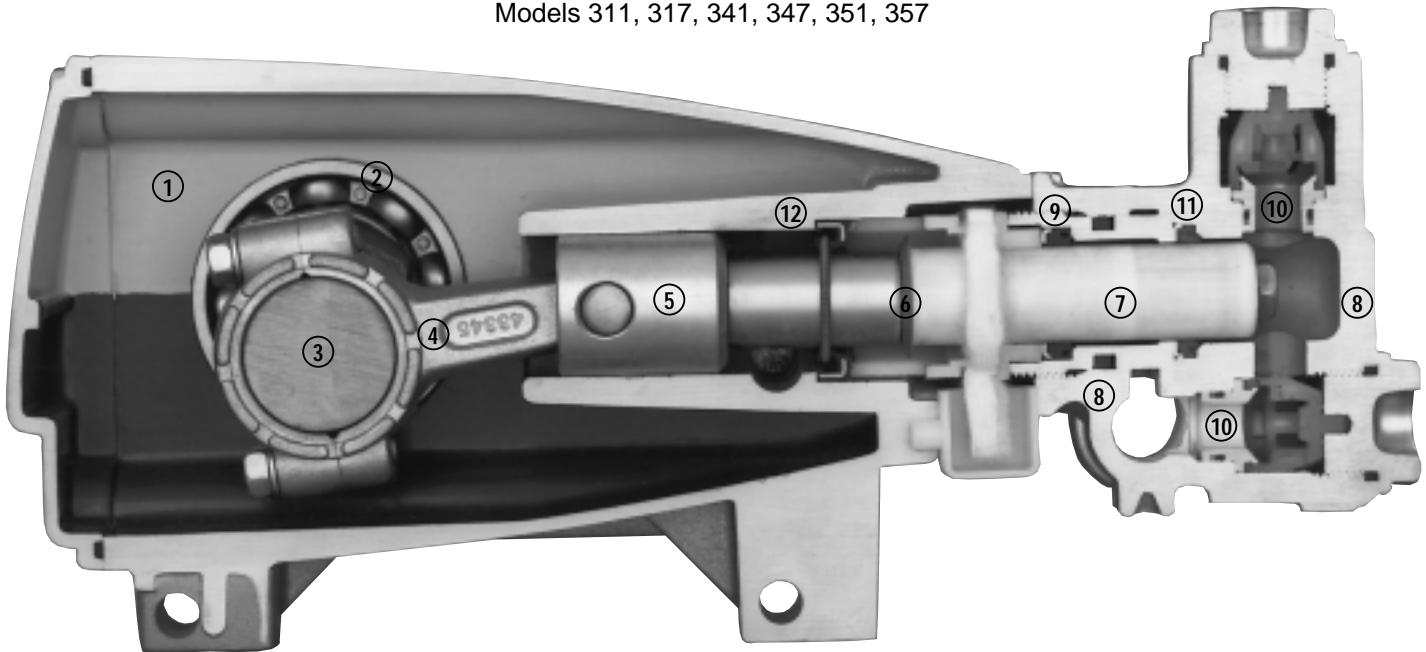

- 1 Die cast aluminum **crankcase** means high strength, lightweight, and excellent tolerance control.
- 2 Oversized crankshaft **bearings** provide extended bearing life and pump performance.
- 3 Chrome-moly **crankshaft** provides unmatched strength and surface hardness for long life.
- 4 Matched oversized high strength **connecting rods** noted for superior tensile strength and bearing quality.
- 5 Special high strength **plunger rods** with Zamak crossheads for longevity and corrosion resistant.
- 6 The stainless steel **slinger** provides back-up protection for the crankcase seal, keeping pumped liquids out of the crankcase.
- 7 Special concentric, high-density, polished, solid ceramic **plungers** provide a true wear surface and extended seal life.
- 8 **Manifolds** are a high tensile strength 316 stainless steel or nickel aluminum bronze for long life, continuous duty and compatibility.
- 9 100% wet **seal** design adds to service life by allowing pumped liquids to cool and lubricate on both sides.
- 10 Stainless steel **valves, seats and springs** provide corrosion-resistance, ultimate seating and extended life.
- 11 Specially formulated, CAT PUMP exclusive, **Hi-Pressure Seals** offer unmatched performance and seal life.
- 12 **Crossheads** are 360° supported for uncompromising alignment.

Products described hereon are covered by one or more of the following U.S. patents 3558244, 3652188, 3809508, 3920356, 3930756 and 5035580

World Headquarters
CAT PUMPS
 1681 - 94th Lane N.E. Minneapolis, MN 55449-4324
 Phone (763) 780-5440 — FAX (763) 780-2958
 e-mail: techsupport@catpumps.com
 www.catpumps.com

International Inquiries
 FAX (763) 785-4329
 e-mail: intlsales@catpumps.com



CAT PUMPS (U.K.) LTD.
 1 Fleet Business Park, Sandy Lane, Church Crookham, Fleet
 Hampshire GU52 8BF, England
 Phone Fleet 44 1252-622031 — Fax 44 1252-626655
 e-mail: sales@catpumps.co.uk

N.V. CAT PUMPS INTERNATIONAL S.A.
 Heiveldekens 6A, B-2550 Kontich, Belgium
 Phone 32-3-450.71.50 — Fax 32-3-450.71.51
 e-mail: cpi@catpumps.be www.catpumps.be

CAT PUMPS DEUTSCHLAND GmbH
 Buchwiese 2, D-65510 Idstein, Germany
 Phone 49 6126-9303 0 — Fax 49 6126-9303 33
 e-mail: catpumps@t-online.de www.catpumps.de