

## 15 Frame Plunger Pump

**Standard Brass  
Model**

**Stainless Steel  
Model**

**650**  
**651**

### FEATURES

#### Superior Design

- Triplex plunger design provides smoother liquid flow.
- V-Packings are completely lubricated and cooled by the liquid being pumped.
- Lubricated Lo-Pressure Seals provide double protection against external leakage.
- Oil bath crankcase assures optimum lubrication.
- Close tolerance concentricity of the ceramic plunger offers perfect alignment and maximizes seal life.

#### Quality Materials

- All stainless steel valves are heat treated and seats are roller burnished for a positive seal and extended valve life.
- Bronze or Duplex Stainless Steel manifolds are strong and corrosion resistance.
- Special concentric, high-density, polished, solid ceramic plungers provide true wear surface and extended seal life.
- Specially formulated, CAT PUMP exclusive, V-Packings offer unmatched performance and seal life.
- Die cast aluminum crankcase provides high strength, minimum weight and precision tolerance control.
- Chrome-moly crankshaft gives unmatched strength and surface hardness.
- Oversized crankshaft bearings with greater loading capacity mean longer bearing life.

#### Easy Maintenance

- Wet-end is easily serviced without entering crankcase, requiring less time and effort.
- Inlet and discharge valve assemblies interchange for easier maintenance without disturbing piping.
- Preset packings mean no packing gland adjustment is necessary, reducing maintenance costs.

#### **⚠ WARNING**

All systems require both a primary pressure regulating device (i.e., regulator, unloader) and a secondary pressure safety relief device (i.e., pop-off valve, safety valve). Failure to install such relief devices could result in personal injury or damage to the pump or to system components. CAT PUMPS does not assume any liability or responsibility for the operation of a customer's high pressure system.

### SPECIFICATIONS

	U.S. Measure	Metric Measure
Flow.....	7.0 GPM	(27 L/M)
Pressure Range.....	100 to 3000 PSI	(7 to 210 BAR)
RPM .....	1000 RPM	(1000 RPM)
Inlet Pressure Range.....	-5 to +60 PSI	(-0.35 to +4 BAR)
Bore.....	.787"	(20 mm)
Stroke.....	1.181"	(30 mm)
Crankcase Capacity .....	42 oz.	(1.26 L)
Maximum Liquid Temperature .....	160°F	(71°C)
Above 130°F call CAT PUMPS for inlet conditions and elastomer recommendations.		
Inlet Ports (2) .....	3/4" NPTF	(3/4" NPTF)
Discharge Ports (2).....	1/2" NPTF	(1/2" NPTF)
Pulley Mounting .....	Either Side	(Either Side)
Shaft Diameter .....	1.181"	(30 mm)
Weight.....	44 lbs.	(19.9 kg)
Dimensions.....	16.28x12.99x6.44"	(413.50x330x163.50 mm)

### ELECTRIC HORSEPOWER REQUIREMENTS

FLOW		PRESSURE			MOTOR PULLEY SIZE	
		PSI 2000	PSI 2500	PSI 3000	Using 1725 RPM Motor 10" O.D. Pump Pulley	
U.S. GPM	L/M	BAR 140	BAR 175	BAR 210	RPM	Pulley O.D.
7.0	27	9.6	12.0	14.4	1000	5.7
6.0	23	8.2	10.3	12.4	858	4.9
5.0	19	6.9	8.6	10.3	715	4.1

**DETERMINING THE PUMP R.P.M.**  $\frac{\text{Rated G.P.M.}}{\text{Rated R.P.M.}}$  = "Desired" G.P.M. / "Desired" R.P.M.

**DETERMINING THE REQUIRED H.P.**  $\frac{\text{GPM x PSI}}{1460}$  = Electric Brake H. P. Required

**DETERMINING MOTOR PULLEY SIZE**  $\frac{\text{Motor Pulley O.D.}}{\text{Pump R.P.M.}}$  =  $\frac{\text{Pump Pulley O.D.}}{\text{Motor R.P.M.}}$

See complete Drive Packages [Incls: Pulleys, Belts, Hubs, Key] Tech Bulletin 003.  
Refer to pump **Service Manual** for repair procedure, additional technical information and **pump warranty**.

*"Customer confidence is our greatest asset"*

# PARTS LIST

ITEM	PART NUMBER			DESCRIPTION	QTY	
	650	MATL	651	MATL		
2	30067	STL	30067	STL	Key (M8x7.5x25)	1
5	92519	STZP	92538	S	Screw, Sems, HHC (M6x16)	8
8	43496	AL	43496	AL	Cover, Bearing	2
9	43520	FBR	43520	FBR	Split Shim, Bearing Cover, 2 Pc.	2
	—	—	45387	S	Split Shim, Bearing Cover, 2 Pc.	2
10	11340	NBR	11340	NBR	O-Ring, Bearing Case - 70D	2
11	43495	NBR	43495	NBR	Seal, Oil, Crankshaft - 70D	2
15	39060	STL	39060	STL	Bearing, Roller	2
20	48600	TNM	48600	TNM	Rod Assy, Connecting [11/00]	3
25	43494	FCM	43494	FCM	Crankshaft - Dual End	1
31	828710	—	828710	—	Protector, Oil Cap	1
32	43211	ABS	43211	ABS	Cap, Oil Filler	1
33	14177	NBR	14177	NBR	O-Ring, Filler Cap - 70D	1
37	92241	—	92241	—	Gauge, Oil, Bubble w/Gasket - 80D	1
38	44428	NBR	44428	NBR	Gasket, Flat, Oil Gauge - 80D	1
40	92520	STZP	92542	S	Screw, Sems HH (M6x20)	4
48	25625	STCP	25625	STCP	Plug, Drain (1/4"x19BSP)	1
49	23170	NBR	23170	NBR	O-Ring, Drain Plug - 70D	1
50	43491	AL	43491	AL	Cover, Rear	1
51	44834	NBR	44834	NBR	O-Ring, Rear Cover - 70D	1
53	43488	AL	43488	AL	Crankcase w/Guide Pins	1
54	27488	S	27488	S	Pin, Guide	2
56	44664	POP	44664	POP	Pan, Oil	1
64	43507	CM	43507	CM	Pin, Crosshead	3
65	43501	SZZ	—	—	Rod, Plunger, Long	3
	—	—	48892	SSHS	Rod, Plunger, Short [3/02]	3
69	43504	STZP	43504	STZP	Washer, Seal	3
70	43500	NBR	43500	NBR	Seal, Oil, Crankcase - 80D	3
75	43506	S	43506	S	Slinger, Barrier	3
88	45675	SS	45675	SS	Washer, Keyhole	3
89	43505	BB	45880	SS	Spacer, Plunger	3
90	43300	CC	43300	CC	Plunger (M20x77)	3
95	—	—	89651	SS	Stud, Plunger Retainer (M6x70)	3
96	43235	PTFE	43235	PTFE	Back-up-Ring, Plunger Retainer	3
97	17399	NBR	17399	NBR	O-Ring, Plunger Retainer - 80D	3
	14160	FPM	14160	FPM	O-Ring, Plunger Retainer - 80D	3
	◆ 46204	EPDM	◆ 46204	EPDM	O-Ring, Plunger Retainer - 70D	3
98	45891	CU	44041	SS	Gasket, Plunger Retainer	3
99	—	—	44031	SS	Retainer, Plunger (M6)	3
	104360	S	—	—	Retainer w/stud, Plunger (M5)	3
100	43509	POP	43509	POP	Retainer, Seal	3
101	43508	—	43508	—	Wick, Long Tab	3
103	44036	S	44036	S	Ring, Retaining	3
106	44071	NBR	44071	NBR	Seal, LPS w/SS-Spg	3
	44381	FPM	44381	FPM	Seal, LPS w/SS-Spg	3
	701974	SFTB*	701974	SFTB*	Seal, LPS w/SS-Spg	3
120	46065	NAB	48465	SSNP	Case, Seal	3
121	14762	NBR	14762	NBR	O-Ring, Seal Case - 70D	3
	11737	FPM	11737	FPM	O-Ring, Seal Case - 75D	3
	◆ 46205	EPDM	◆ 46205	EPDM	O-Ring, Seal Case - 70D	3
126	43515	BB	48388	D	Adapter, Female	1
127	44607	STG*	44607	STG*	V-Packing	6
	44386	FPM	44386	FPM	V-Packing	6
128	43517	BB	44165	SS	Adapter, Male	3
139	20326	BBCP	44382	SS	Plug, Inlet (3/4" NPT)	1
162	43248	PTFE	43248	PTFE	Back-up-Ring, Seat	6
163	43249	NBR	43249	NBR	O-Ring, Seat - 80D	6
	44383	FPM	44383	FPM	O-Ring, Seat - 70D	6
	◆ 46206	EPDM	◆ 46206	EPDM	O-Ring, Seat - 70D	6
164	43722	S	44037	SS	Seat	6
166	43721	S	48793	SSL	Valve	6
167	43751	S	44039	SS	Spring	6
168	44564	PVDF	44564	PVDF	Retainer, Spring	6
172	17617	NBR	17617	NBR	O-Ring, Valve Plug - 90D	6
	11691	FPM	11691	FPM	O-Ring, Valve Plug - 90D	6
	◆ 46207	EPDM	◆ 46207	EPDM	O-Ring, Valve Plug - 70D	6
174	43851	BBCP	48463	SSNP	Plug, Valve	6
	43850	BB	—	—	Plug, Valve	6
185	45975	NAB	48780	SSD	Head, Manifold	1
187	14050	STZP	44005	S	Stud (M10x45)	4
192	12503	STZP	15847	S	Lockwasher (M10)	4
194	81048	STZP	81258	S	Nut, Hex (M10)	4
250	30764	NY	30764	NY	Protector, Shaft w/2 Screws	1
255	30264	STZP	30264	STZP	Kit, Direct Mount	1
260	30613	STZP	30613	STZP	Mount, Rail Assy - A (30635,30903,30921,30912)	1
	990550	STZP	990550	STZP	Mount, Rail (Required on Diesel/Gas)	1
269	30206	F	30206	F	Pulley (10") AB [See Drive Packages, Tech Bulletin 003]	1
274	30059	STL	30059	STL	Hub, "H" (M30) (Keyway M8) [See Drive Packages, Tech Bulletin 003]	1

# EXPLODED VIEW

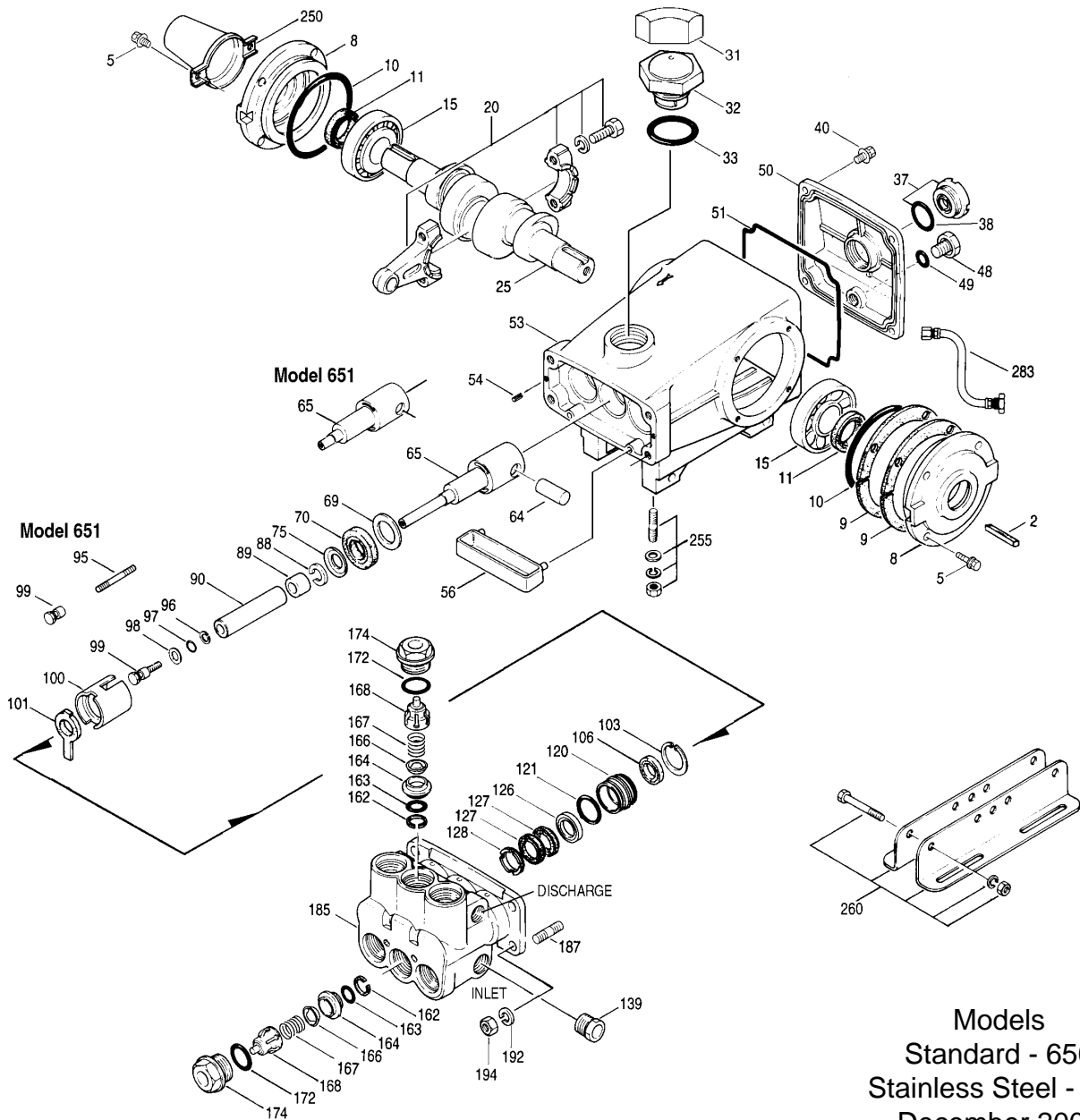

Models  
Standard - 650  
Stainless Steel - 651  
December 2008

	<b>650</b>	<b>MATL</b>	<b>651</b>	<b>MATL</b>		
283	34334	—	34334	—	Kit, Oil Drain	1
299	<b>814561</b>	<b>BB</b>	<b>816780</b>	<b>SS</b>	Head, Complete	1
300	30798	NBR*	30798	NBR*	Kit, Seal (Incls: 97,103,106,121,127)	1
	31033	FPM	31033	FPM	Kit, Seal (Incls: 97,103,106,121,127)	1
	◆ 33919	EPDM*	◆ 33919	EPDM*	Kit, Seal (Incls: 97,103,106,121,127)	1
310	<b>30820</b>	<b>NBR</b>	<b>34387</b>	<b>NBR</b>	Kit, Valve (Incls: 162,163,164,166,167,168,172)	2
	<b>31256</b>	<b>FPM</b>	<b>30987</b>	<b>FPM</b>	Kit, Valve (Incls: 162,163,164,166,167,168,172)	2
	◆ <b>31253</b>	<b>EPDM</b>	◆ <b>31258</b>	<b>EPDM</b>	Kit, Valve (Incls: 162,163,164,166,167,168,172)	2
350	30696	STZP	30696	STZP	Plier, Reverse	1
351	43523	STZP	43523	STZP	Tool, Seal Case Removal	1
	33006	STZP	33006	STZP	Socket, Seal Case 1/2" Drive	1
352	44050	STZP	44050	STZP	Tool, Oil Gauge Removal	1
—	6107	—	6107	—	Oil, Bottle (21 oz.) ISO-68 Hydraulic (Fill to specified crankcase capacity prior to start-up)	1
—	6575	—	6575	—	Plunger Pump Service DVD	

**Bold part numbers are unique to a particular pump model. Italics are optional items. [ ]** Date of latest production change.  
◆ Silicone oil/grease required. \* Review material codes for individual items (HT generally may be used as alternate).  
See Tech Bulletins 002, 003, 024, 027, 035, 036, 043, 045, 048, 049, 052, 053, 062, 074, 077 and 083 for additional information.

**C. A.T. highly recommended for pressurized inlet, R.O. and Industrial applications.**

MATERIAL CODES (Not Part of Part Number): ABS=ABS Plastic AL=Aluminum BB=Brass BBCP=Brass/Chrome Plated CC=Ceramic CM=Chrome-Moly CU=Copper  
D=Acetal EPDM=Ethylene Propylene Diene Monomer F=Cast Iron FBR=Fiber FCM=Forged Chrome-Moly FPM=Fluorocarbon NAB=Nickel Aluminum Bronze  
NBR=Medium Nitrile (Buna-N) NY=Nylon POP=Polypropylene PTFE=Pure Polytetrafluoroethylene PVDF=Polyvinylidene Fluoride S=304SS  
SFTB=Special Blend PTFE Black SS=316SS SSD=Duplex Stainless SSHS=316SS/High Strength SSL=316SS/Low Carbon SSNP=316SS/Nickel Plated  
STCP=Steel/Chrome Plated STG=Special Blend PTFE White STL=Steel STZP=Steel/Zinc Plated SZZ=304SS/Zamak TNM=Special High Strength

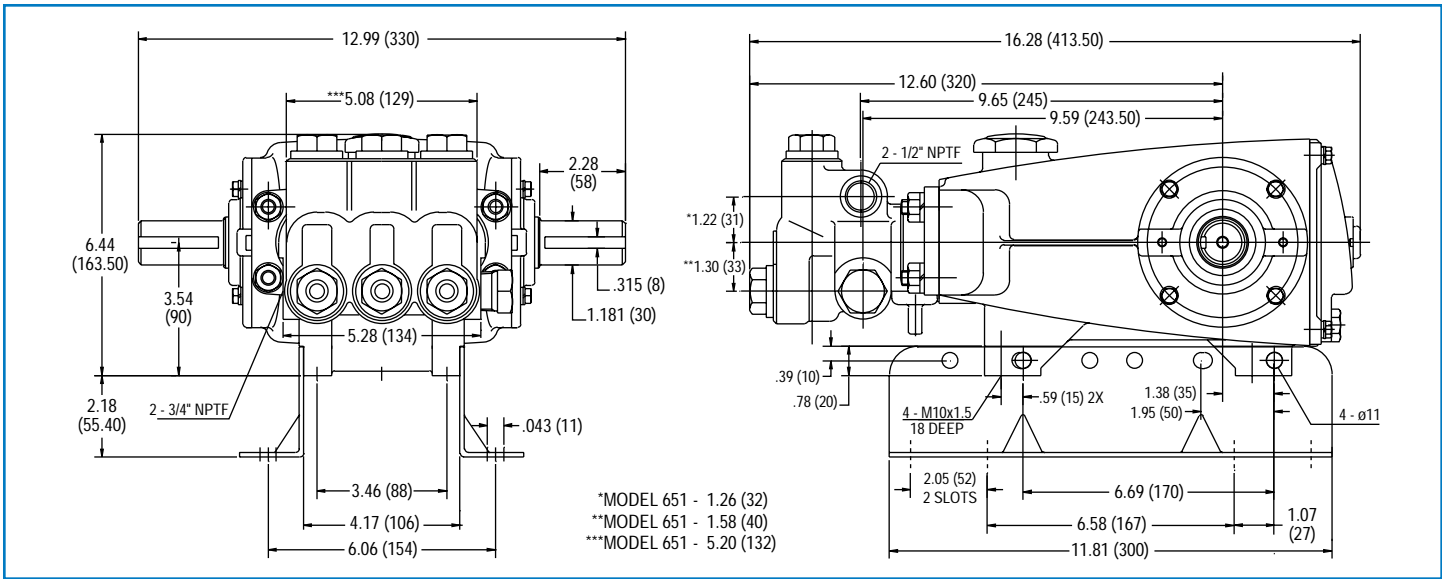

Models 650, 651

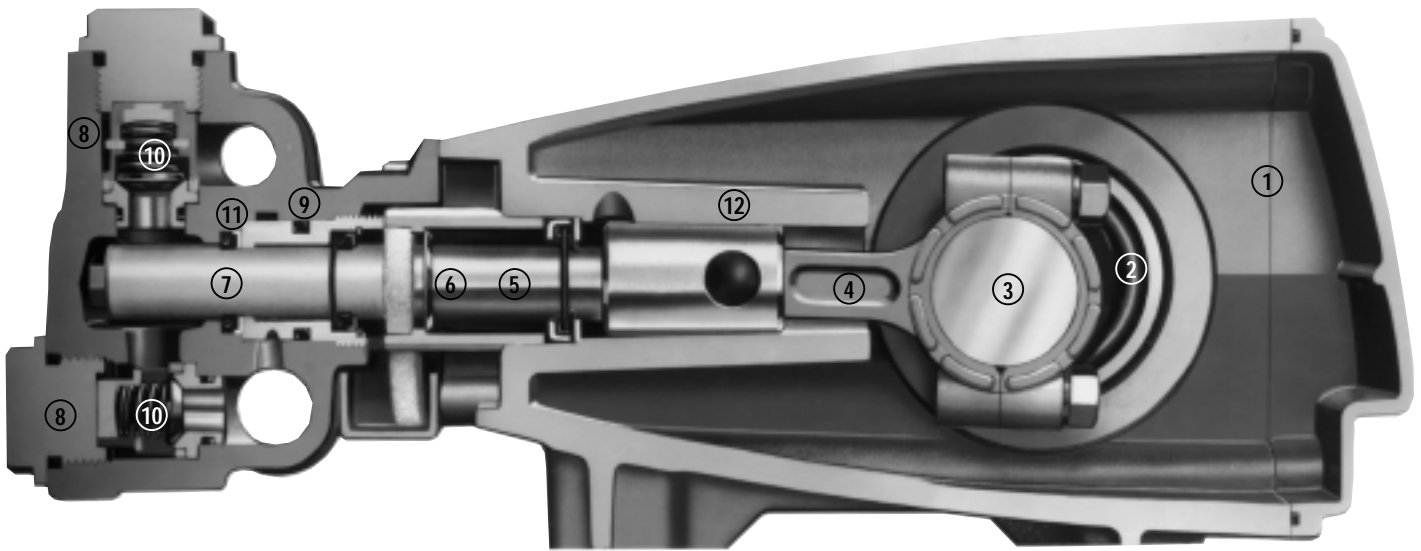

- 1 Die cast aluminum **crankcase** means high strength, lightweight, and excellent tolerance control.
- 2 Oversized crankshaft **bearings** provide extended bearing life and pump performance.
- 3 Chrome-moly **crankshaft** provides unmatched strength and surface hardness for long life.
- 4 Matched oversized high strength **connecting rods** are noted for superior strength and bearing quality.
- 5 Special stainless steel **plunger rods** with high strength crossheads for longevity and corrosion resistance.
- 6 The stainless steel **slinger** provides back-up protection for the crankcase seal, keeping pumped liquids out of the crankcase.
- 7 Special concentric, high-density, polished, solid ceramic **plungers** provide a true wear surface and extended seal life.
- 8 **Manifolds** are a high tensile strength bronze or Duplex stainless steel for long term, continuous duty and corrosion resistance.
- 9 100% wet **seal** design adds to service life by allowing pumped liquids to cool and lubricate on both sides.
- 10 Stainless steel **valves, seats and springs** provide corrosion-resistance, positive seating and long life.
- 11 Specially formulated, CAT PUMP exclusive, **V-Packings** offer unmatched performance and seal life.
- 12 **Crossheads** are 360° supported for uncompromising alignment.

Products described hereon are covered by one or more of the following U.S. patents 3558244, 3652188, 3809508, 3920356, 3930756 and 5035580

**World Headquarters**  
**CAT PUMPS**  
 1681 - 94th Lane N.E. Minneapolis, MN 55449-4324  
 Phone (763) 780-5440 — FAX (763) 780-2958  
 e-mail: techsupport@catpumps.com  
 www.catpumps.com

**International Inquiries**  
 FAX (763) 785-4329  
 e-mail: intlsales@catpumps.com



**CAT PUMPS (U.K.) LTD.**  
 1 Fleet Business Park, Sandy Lane, Church Crookham  
 FLEET, Hampshire, GU52 8BF, England  
 Phone Fleet 44 1252-622031 — Fax 44 1252-626655  
 e-mail: sales@catpumps.co.uk www.catpumps.co.uk

**N.V. CAT PUMPS INTERNATIONAL S.A.**  
 Heiveldekens 6A, B-2550 Kontich, Belgium  
 Phone 32-3-450.71.50 — Fax 32-3-450.71.51  
 e-mail: cpi@catpumps.be www.catpumps.be

**CAT PUMPS DEUTSCHLAND GmbH**  
 Buchwiese 2, D-65510 Idstein, Germany  
 Phone 49 6126-9303 0 — Fax 49 6126-9303 33  
 e-mail: catpumps@t-online.de www.catpumps.de