

SERVICE MANUAL

MOYNO[®]
2000 Pumps
G1 Flanged Models

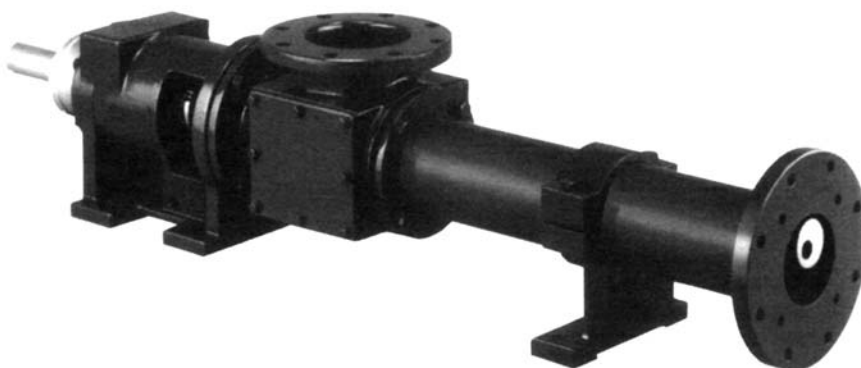

MOYNO

Always the Right Solution™

TABLE OF CONTENTS

	Page		Page
1-1. INTRODUCTION	1	4-19. Seals.....	7
1-2. GENERAL.....	1	4-20. Packing.....	7
1-3. NAMEPLATE DATA.....	1	4-21. Rotor.....	7
1-4. Pump Rotation.....	1	4-22. Stator.....	7
1-5. Model Number.....	1	4-23. All Other Parts.....	7
1-6. Frame Size Designation.....	1	4-24. ASSEMBLY	
1-7. Type Designation.....	1	4-25. Lubrication During Assembly.....	7
1-8. Trim Code.....	2	4-26. Packing Installation.....	8
1-9. Variation of Standard Parts.....	2	4-27. Bearing Housing/Suction Housing Assembly.....	8
2-1. INSTALLATION	2	4-28. Bearing/Drive Shaft Assembly.....	8
2-2. GENERAL.....	2	4-29. Rotor/Stator Assembly.....	9
2-3. PIPING.....	2	4-30. Rotor Gear Joint Assembly.....	9
2-4. Suction Piping.....	2	4-31. Rotor/Stator to Drive End Assembly.....	10
2-5. Suction Housing Rotation.....	2	4-32. Drive End Gear Joint Assembly.....	10
2-6. Discharge Piping.....	2	4-33. Stator Support/Discharge Assembly.....	11
2-7. FOUNDATION.....	3	4-34. Final Assembly.....	11
2-8. SHAFT ALIGNMENT.....	3	4-35. Packing Adjustment.....	11
2-9. On Coupling Connected Units.....	3	4-36. STORAGE	11
2-10. On Belt Drive Units.....	3	4-37. Short Term Storage.....	11
2-11. WATER FLUSH OF PACKING.....	3	4-38. Long Term Storage.....	11
3-1. OPERATION	4	4-39. PACKING SPECIFICATION	12
3-2. INITIAL CHECK.....	4	4-40. VARIATIONS OF STANDARD PARTS	12
3-3. START-UP.....	4	4-41. Rotors.....	12
3-4. PACKING LEAKAGE.....	4	4-42. Drive Shafts.....	12
4.1. MAINTENANCE	4	4-43. STANDARD HARDWARE	13
4-2. GENERAL.....	4	4-44. SELECTING THE CORRECT PART	14
4-3. PACKING ADJUSTMENT.....	4	4-45. PARTS LIST	15
4-4. PACKING REPLACEMENT.....	5	4-46. SHAFT SLEEVE ARRANGEMENT	24
4-5. LUBRICATION.....	5	4-47. Disassembly.....	24
4-6. Bearings.....	5	4-48. Assembly.....	24
4-7. Gear Joints.....	5	4-49. FIBER DEFLECTOR OPTION	
4-8. DISASSEMBLY.....	5	4-50. OPERATION.....	26
4-9. Disconnect Pump.....	5	4-51. DISASSEMBLY/ASSEMBLY.....	26
4-10. Packing Removal.....	5	4-52. PARTS LIST.....	26
4-11. Stator Removal.....	5	4-53. FLUSH GLAND OPTION	26
4-12. Drive End Gear Joint Removal.....	6	4-54. GENERAL.....	26
4-13. Rotor and Connecting Rod Removal.....	6	4-55. INSTALLATION.....	26
4-14. Drive Shaft and Bearings Removal.....	6	4-56. OPERATION.....	27
4-15. CLEANING.....	6	4-57. STANDARD HARDWARE.....	28
4-16. INSPECTION.....	7	4-58. PARTS LIST.....	28
4-17. Bearings.....	7	4-59. TROUBLESHOOTING CHART	29
4-18. Drive Shaft.....	7		

Note: This service manual outlines installation, operation and maintenance procedures for the flanged "G1" models of the Moyno 2000 pump. For information on the open throat (G2) and/or the bridge breaker (G3) models of the Moyno 2000 pump, refer to the G2/G3 Service Manual, or contact your nearest Moyno pump representative.

SERVICE MANUAL

MOYNO® 2000 PUMPS

G1 Flanged Models

1-1. INTRODUCTION

1-2. GENERAL

The Moyno® 2000 Pump is the culmination of over 70 years of experience in manufacturing and marketing fluids handling equipment. This rugged pump has been engineered to be the most reliable product ever sold under the Moyno name. The pump has been painstakingly tested to assure consistent performance in the most difficult of applications. It represents the next generation of the world's most versatile pump.

The Moyno 2000 Pump is a progressing cavity pump. A single helical rotor rolling eccentrically in the double helix of the stator creates the pumping action. The rotor in conjunction with the stator forms a series of sealed cavities 180 degrees apart. As the rotor turns, the cavities progress from the suction to the discharge. As one cavity diminishes, the opposing cavity increases at exactly the same rate. Thus the sum of the two discharges is a constant volume. The result is a pulsation-free positive displacement flow utilizing no valves.

1-3. NAMEPLATE DATA

The pump nameplate, located on the bearing housing, contains important information relating to the operation and servicing of the pump. This information includes the direction of rotation arrow and the pump model and serial numbers (see fig. 1-1). The pump model number must be used for reference when ordering spare parts.

1-4. Pump Rotation. A rotation arrow on the nameplate indicates the direction of rotation. Normal rotation of Moyno 2000 pumps is clockwise, when viewed from the driven end of the pump.

1-5. Model Number. The pump model number consists of three component parts: Frame Designation, Type Designation and a Trim Code. A typical model number for example, might be 1G065G1 CDQ AAA, as shown on the nameplate in fig. 1-1.

1-6. Frame Designation. The Moyno 2000 is modular in concept allowing for optimal matching of drive ends and pump elements (rotor and stator) to meet the requirements of the application. The seven or more characters in the frame

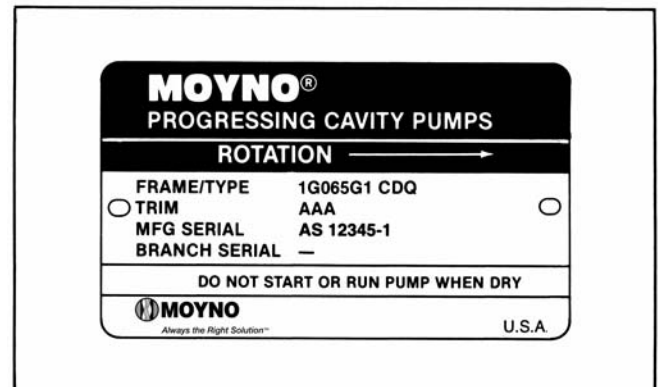

Figure 1-1. Typical nameplate showing rotation arrow, model and manufacturing serial numbers.

designation describe the particular combination of drive end and pump elements, as well as other construction details of your pump.

The first character in the frame designation, always a number, indicates the number of stages of the pumping elements.

The second character is always a letter (E through K) and indicates the drive end size.

The third, fourth and fifth characters are numbers indicating the theoretical capability of the pumping elements per 100 revolutions on water. Sometimes the fifth letter is followed by the letter "E", which denotes that the pumping element is our Ultra Pro 23 geometry.

The sixth character represents the type of universal joint utilized. The letter G indicates a gear type joint. Other configurations may be indicated by the letters P or F.

The seventh character, a number, indicates the type of suction housing. Flanged suction port pumps are designated by the numeral "1," open throat pumps by the numeral "2" and open throat pumps with a bridge breaker option by the numeral "3."

1-7. Type Designation. Following the Frame Designation is the Type Designation, a series of three letters describing the materials from which the pump is constructed.

The first letter identifies the material of the suction housing.

- C — Cast Iron
- E — Carpenter 20 Stainless Steel*
- H — Hastelloy "C" **
- M — Monel***
- S — 316 Stainless Steel
- W — Cast Steel
- X — Special to application

Note: The bearing housing of the pump is always made of cast iron.

The second letter indicates the material used in the drive shaft, connecting rod, rotor and other wettable parts.

- D — Alloy Steel
- E — Carpenter 20 Stainless Steel*
- G — 416 Stainless Steel
- H — Hastelloy "C" **
- J — 17-4 PH Stainless Steel
- M — Monel***
- S — 316 Stainless Steel
- X — Special to application

The third letter indicates the material of the stator. It identifies only the stator material and not that of the tube in which the stator is placed, which is always carbon steel. Standard stator materials used in the Moyno 2000 pump are as follows:

- B — EPDM 300, 70 Durometer
- C — Nitrile 103, 50 Durometer
- D — Tool Steel
- E — Nitrile 110, 70 Durometer
- F — Fluoroelastomer 500, 75 Durometer
- G — 416 Stainless Steel
- H — Hastelloy "C" **
- J — 17-4 PH Stainless Steel
- K — Hypalon 800, 70 Durometer †
- M — Nitrile 100M 70 Durometer
- P — Thiokol 70 Durometer ‡
- Q — Nitrile 100, 70 Durometer
- R — Natural Rubber 200, 55 Durometer
- I — Teflon 15% glass †
- U — Urethane 70 Durometer
- X — Special to application
- Z — White Nitrile 150, 70 Durometer

A typical type designation such as CDQ, would identify the following materials of construction:

- C = Cast iron suction housing
- D = Alloy steel rotor, drive shaft, connecting rod and other minor metallic parts in contact with the fluid being pumped.
- Q = Nitrile (70 durometer) stator

* Carpenter 20 is a trademark of Carpenter Technology Corp.

** Hastelloy is a trademark of Cabot Corp.

*** Monel is a trademark of INCO Alloy Corp.

† Hypalon and Teflon are trademarks of E.I. DuPont de Nemours and Company

‡ Thiokol is a trademark of Morton Thiokol Inc.

1-8. Trim Code. Also included in the Model Number is the three character Trim Code which is used to identify pump construction. The letters "AAA" signify standard construction, with letters other than "A" signifying variations. The first letter identifies sealing variations; the second, internal variations; and the third, rotor variations.

1-9. Variations of Standard Parts. Refer to Sections 4-40 through 4-42 for variations available for modifying pumps to meet specialized pumping conditions. If the trim code of your pump is other than "AAA," contact your nearest Moyno representative for clarification. Do not modify your pump with any variation unless you have determined that it is compatible with your application.

2-1. INSTALLATION

2-2. GENERAL

Moyno pumps are lubricated and tested at the factory prior to shipment and require minimum pre-start up maintenance. Packing, however, is not lubricated at the factory.

Accessibility to the pump and adequate clearance should be a prime consideration in any installation. Enough space should surround the unit so that maintenance can be carried out with ease.

2-3. PIPING

2-4. Suction piping should be as short as possible. Normally, the suction line should be the same size as the pump suction; however, conditions, such as high viscosity or flow velocities, may dictate otherwise. Long-sweep 90-degree elbows or 45-degree elbows should be used instead of standard elbows. Piping configurations, which trap air, should be avoided.

2-5. Suction housing rotation to any position 360° about the centerline of the pump is possible. To rotate, loosen the hex head bolts holding the clamp ring to the bearing housing. Remove the packing gland halves and the packing studs. Loosen the stator support cap and rotate the suction housing, stator and discharge flange together. Replace the packing gland studs in the threaded hole provided.

CAUTION: Rotating the suction flange by any other method may tear the stator gaskets causing a leak. Once the gaskets have been compressed, it is virtually impossible to rotate any one of the two compressing surfaces without tearing the gasket.

2-6. Discharge piping diameter should generally be as large as the pump ports unless fluid conditions indicate otherwise.

An easily removable section of piping one-to-two times longer than the connecting rod should be mated to the discharge port. This will allow the stator to be removed without having to disassemble the complete pump.

2-7. FOUNDATION

Each unit should be mounted on a strong, fabricated-steel base plate. The base plate should be mounted on a concrete foundation. The foundation should be approximately 4" to 8" longer and wider than the base for which it is built. (See fig. 2-1.) Anchor bolts for the base plate should be located in the foundation.

Figure 2-1. Typical Foundation Example

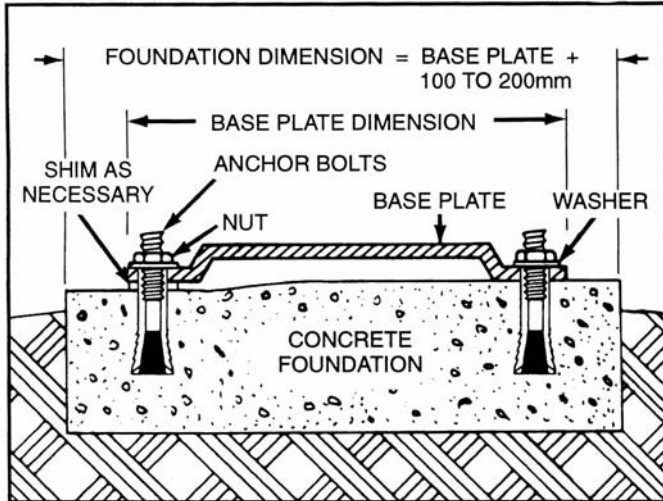

Check the base plate surface with a carpenter's level and place shims under the base plate at the places necessary to make it level. Then check the pump, driver shaft and the pump ports to ensure that they are level. Complete base mounted units supplied by Moyno including pump and driver are leveled with respect to the base at the factory. Shifting may occur during shipment. The pump and driver should be realigned. Care should be exercised to ensure that all components are level and mounted in a direct line.

For maximum rigidity and lower noise levels the base plate should be grouted to the foundation after the anchor bolts have been evenly tightened. A good grade of non-shrink grout is recommended. The spaces between the base plate and the foundation around the shims should also be filled with grout. Allow the grout to dry according to manufacturer's instructions, then fully tighten the anchor bolts.

2-8. SHAFT ALIGNMENT

Although the base-mounted units supplied by Moyno are leveled with respect to the base before shipment, most of the larger pump and driver units are shipped with the flexible coupling disconnected.

After the base has been bolted down to the foundation, check the following conditions:

2-9. On coupling connected units, be sure that the pump and driver shafts are realigned before the coupling is connected. Care should be exercised to ensure that all components are level and mounted in a direct line.

Check gap between coupling halves (refer to coupling manufacturers recommendations). Adjustment can usually be accomplished by loosening the mounting bolts on either the pump or driver and moving the loosened component into alignment with the fixed component. On couplings with equal diameter hubs, it may be possible to lay a straight edge axially across the coupling halves to check alignment.

2-10. On belt drive units, check to ensure that sheaves or sprockets are in alignment. Check belts for proper tension. Tension requirements will vary with type of belt, center distances, and belt speeds. Consult belt manufacturer for specific recommendation.

2-11. WATER FLUSH OF PACKING

The packing may be either grease lubricated through a grease fitting in the stuffing box or have plumbing connected to the housing to allow for water flushing.

Packing is not grease lubricated at the factory prior to shipping.

When the material being pumped is abrasive, water flushing the packing is recommended to extend shaft life.

Clean water can be injected through a 1/8" NPT hole that normally houses the grease fitting for lubricating the packing. The water should be permitted to leak axially along the shaft and be removed from the second tapped hole in the stuffing box. The discharge from the stuffing box should be throttled slightly to maintain 10-15 PSI higher pressure in the stuffing box than is present in the suction housing. (See fig. 2-2.) Flow rate should be approximately 1/2-2 gpm.

If a mechanical seal is used, consult the seal manufacturers' instructions for seal flush requirements.

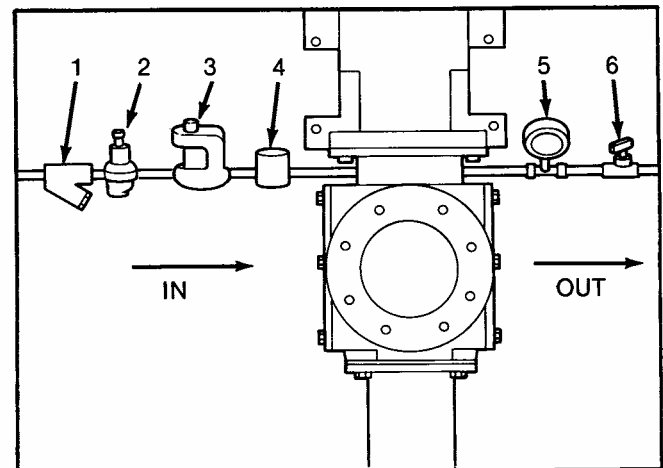

Figure 2-2. Typical water flush arrangement for units with packing includes strainer valve (1), pressure regulating valve (2), sight flow meter (3), solenoid valve (4), pressure gauge (5), and needle valve (6).

3-1. OPERATION

3-2. INITIAL CHECK

Before putting the pump into operation, the following items should be checked to ensure that each piece of equipment is installed correctly:

- Pump, driver, coupling or sheave alignment.
- Electrical connections.
- Gauges and other instruments.
- Water flush connection to the stuffing box.
- Pump rotation. Normal rotation is indicated on the nameplate on the bearing housing.
- All valves should be open on both suction and discharge sides of pump.

CAUTION: This is a positive displacement pump. Do not operate it against a closed valve.

3-3. START-UP

CAUTION: DRY OPERATION IS HARMFUL TO THE PUMP! Never allow the pump to operate without liquid, as dry operation will cause premature wear of the stator and possible damage. The stator is lubricated by the liquid, which is pumped.

1. Before operating the pump for the first time, fill it with liquid (the drain plug hole on the suction housing may be used for filling). If the liquid to be pumped is highly viscous, dilute it before filling the pump. The liquid fill-up will lubricate the stator for the initial start-up.

2. Once the pump has been filled with liquid, check for direction of pump rotation by momentarily starting and stopping the drive. Check rotation arrow on pump nameplate for correct rotation.

3. In suction lift applications, when water flush is not utilized it may be necessary to replace the zerk fittings at the stuffing box (in suction housing) with pipe plugs to prevent loss of prime due to air leakage.

4. If applicable, turn on the water to the packing.

5. Start pump.

3-4. PACKING LEAKAGE

A packed stuffing box is designed to control leakage, not stop it completely. Leakage is generally necessary to reduce friction and dissipate heat. The amount of leakage necessary will depend on the fluid pumped, the installation, and pump speed and type. Refer to Section 4-3 for packing adjustment.

Moyno 2000 pumps have been designed for minimum stuffing box leakage when properly maintained. If leakage cannot be tolerated, then a mechanical seal should be used.

4-1. MAINTENANCE

Note: In this section, the first reference to each pump part will be followed by a number or a letter in parentheses (). These numbers and letters are those used to identify the pump parts and hardware items in the fold-out Exploded View (Figure 4-8).

4-2. GENERAL

The Moyno 2000 pump has been designed for a minimum of maintenance, the extent of which is routine adjustment and lubrication of packing. The pump is one of the easiest to work on, in that the main elements are very accessible and require few tools to disassemble.

4-3. PACKING ADJUSTMENT

Packing gland nuts should be evenly adjusted so they are little more than finger tight. (See fig. 4-1.) Over-tightening the packing gland may result in premature packing failure and possible damage to the shaft and gland.

When packing is new, frequent minor adjustments during the first few hours of operation are recommended in order to compress and seat each ring of packing evenly.

1. Upon initial start-up of the pump, adjust the gland nuts for a leakage rate of 1-2 drops per second until the packing has seated and adjusted to the operating temperature (approximately 10-15 minutes).

2. If leakage is excessive after 15 minutes of operation, tighten the gland nuts until a desired leakage rate is obtained.

CAUTION: Do not tighten until zero leakage is obtained. Over-tightening of the packing gland may result in accelerated wear on the packing and damage to the shaft. In those situations where no packing leakage can be tolerated, consult your Moyno Authorized Service Representative.

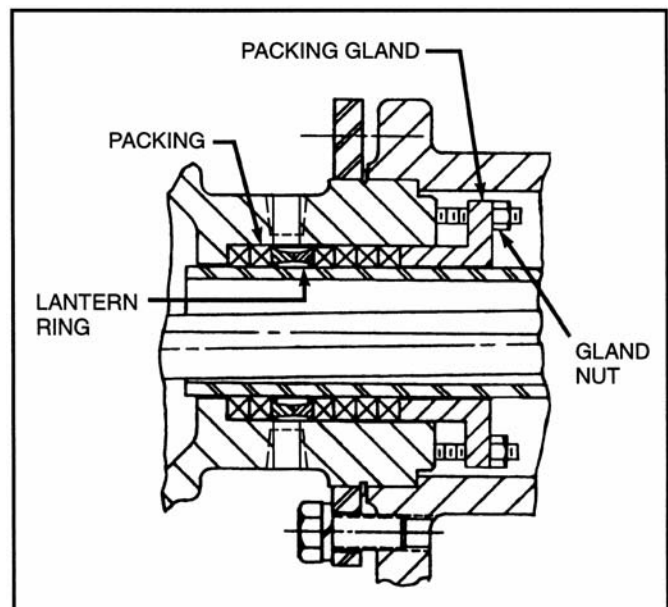

Figure 4-1. Cross Section of Stuffing Box

4-4. PACKING REPLACEMENT

When leakage can no longer be regulated by tightening the gland nuts, remove and replace the packing. Replace as follows:

1. Remove packing gland nuts (F), and slide gland (21) and slinger ring (20) back along drive shaft (14).
2. Remove packing gland studs.
3. Use a pair of packing extractors (Figure 4-2) to remove four packing rings (22), lantern ring halves (23) and two additional packing rings (22).

Figure 4-2. Packing Removal Tool



3. Inspect surface of drive shaft for wear or grooves. If shaft is worn through the chrome plating into the base metal, or is badly scored or grooved it should be replaced.

4. If drive shaft is not worn, install two rings of packing, the lantern ring halves, and four more rings of packing; lubricating them before installation with a good grade of packing grease. Be sure to stagger the packing ring joints at 90° increments. (See Section 4-26.)

CAUTION: Always use a proper packing tamper tool to install packing. Do not use a pointed or sharp tool, as damage to the packing material or drive shaft could result. To assure proper shaft lubrication, never use a one-piece spiral wrap packing.

5. Replace packing gland (21) and secure with packing gland nuts. (See fig. 4-1.)

6. Adjust packing per Section 4-3.

4-5. LUBRICATION

4-6. Bearings. The bearings are lubricated at the factory and will only need to be re-lubricated when the shaft/bearing assembly is removed from the pump.

4-7. Gear Joints. Both gear joints are packed with lubricant during assembly, and will only need to be re-lubricated when gear joints are disassembled.

4-8. DISASSEMBLY

Note: The following instructions cover ONE procedure for disassembling all pump components. Major pump components can be disassembled in various ways since specific installation location limitations will determine method of component removal.

4-9. Disconnect Pump

1. Flush the pump (preferably with clean water) to remove the pumpage from the unit.

2. Shut off pump.
3. Close suction and discharge valves.
4. Turn off flush water to packing or mechanical seal, if used.
5. Disconnect power source.
6. Drain any fluid in pump by removing the drain plug or inspection plate.
7. Remove inspection plate (32) and gasket (33).

4-10. Packing Removal

1. Shut off pump.
2. Complete Section 4-9, steps 3 - 6.
3. Remove gland adjustment nuts (F), gland studs (H) and gland halves (21) from stuffing box.
4. Remove packing rings (22). This is best done by using flexible packing extractors (see fig. 4-2). Use two extractors simultaneously on opposite sides of each ring. Pull evenly.
5. Remove lantern rings (23) in similar fashion. Twist split rings to remove from shaft.
6. Remove additional packing rings.

4-11. Stator Removal

1. Complete Section 4-9.
2. Remove section of discharge pipe attached to discharge flange (37).
3. Remove top half of stator support (31).
4. Unbolt stator clamp ring (36A) from suction housing (29). Pull stator off rotor (see note below). Remove stator gasket (34). Use a screwdriver tip to carefully remove stator retaining ring (35). (See fig. 4-3.) Remove stator clamp ring (36) from stator (30).



Figure 4.3. Typical Retaining Ring Removal

NOTE: On multiple stage pumps, or when cleaning, checking or changing stator (30), rotor (40), and/or gear joint assembly, one of the following procedures is suggested for removing the stator.

Method 1: Utilize Moyno's Hydraulic Stator Removal Device (SRD). See separate SRD service manual or contact the local Moyno distributor for further information on this new product.

Method 2: Use winch-type device anchored directly opposite stator end. Attach cable to discharge flange (37) to pull stator (30) off rotor (40).

Method 3: Remove stator (30), rotor (40) and connecting rod (38) as a single unit (See Section 4-13). Place the stator (30) in an upright position on the discharge flange (37). Remove rotor (40) and connecting rod (38) from the stator (30). It may be necessary to use a chain or sling with a lifting device. Anchor discharge flange (37) securely to the floor before lifting.

Method 4: Hold stator (30) with pipe or strap wrench and turn drive shaft had (4) clockwise to unscrew stator (30) from rotor (40).

5. Remove discharge flange by unbolting from stator clamp ring (36B) and remove stator gasket (34). Remove stator retaining ring (35) and stator clamp ring from stator (30).

6. Check rotor (40) and stator (30) for wear. See Sections (4-21) and (4-22) for instructions.

4-12. Drive End Gear Joint Removal

1. Complete Section 4-9.

2. Remove drive coupling or V-belts and pulley from drive shaft head (4).

3. Remove vent plugs (C) from drive shaft head (4) and drive shaft (14). Remove set screw (D) from drive shaft (14). Remove six socket head screws (E) from drive shaft head (4) and remove drive shaft head. Remove primary thrust plate (6) from drive shaft head and remove two keys (7).

4. Remove lock nut (9) from end of connecting rod (38). Remove ring gear (8), gear ball (10), secondary thrust plate (11), seal support (12), and gear joint seal (13).

Note: It is recommended that each time the drive end gear joint is disassembled, the drive shaft O-ring (5) and gear joint seal (13) should be replaced.

4-13. Rotor and Connecting Rod Removal

1. Complete Sections 4-9, 4-11 and 4-12.

2. Pull the rotor/connecting rod assembly from the pump. Remove the vent plug (C) and set screw (S) from the gear joint shell (39).

3. Remove six socket head screws (T) from head ring (42) and remove head ring and O-ring (41). Slide connecting rod/gear joint assembly off rotor head. Remove gear joint keys (7) and primary thrust plate (6) from rotor (40).

4. Slide gear joint shell (39) off gear ball/connecting rod assembly. Slide ring gear (8) off gear ball (10).

5. Clamp connecting rod (38) in vice or hold with pipe wrench and remove lock nut (9). Remove gear ball (10), secondary thrust plate (11), seal support (12), and gear joint seal (13) from connecting rod.

Note: It is recommended that each time the rotor end gear joint is disassembled, the rotor head O-ring (41) and gear joint seal (13) should be replaced.

4-14. Drive Shaft and Bearings Removal

Note: If the space immediately in front of the pump is unobstructed for a distance equal to the length of the drive shaft, follow steps 1 through 3.

1. Complete Sections 4-9 and 4-12.

2. Remove six hex head screws (A) from bearing cover plate (2). Slide bearing cover plate (2) with radial grease seal (1) and O-ring (3) off drive shaft.

3. Pull drive shaft/bearing assembly out of bearing housing, taking steps to support the weight of the assembly as the bearings clear the housing. Remove grease seal (19) from the bearing housing.

Note: If the space in front of the pump is obstructed, and the obstruction is not easily moveable, follow steps 4 through 6.

4. Complete Sections 4-10 and 4-11, and pull the rotor/connecting rod assembly from the pump.

5. Remove the four cap screws (0) from the clamp ring (28), and the four cap screws fastening the bearing Housing (26) to the base. Slide the bearing housing/shaft assembly out of the suction housing until the quill clears the stuffing box. Assembly may now be turned or removed to an area where sufficient space is available to permit removal of the shaft/bearing assembly.

Note: Some pumps have a sleeve installed on the drive shaft to receive any possible wear caused by the packings. (See fig. 4-10.) To remove sleeve, refer to Section 4-47.

CAUTION: The bearings are pressed on the shaft during assembly. Care must be taken during disassembly to avoid damaging the bearings or shaft.

6. Remove bearing lock screw (17) from bearing nut (18). Using suitable spanner wrench or soft punch and hammer, thread lock nut off drive shaft. Do not use a pipe wrench to remove the lock nut.

7. Remove both halves of bearing spacer (16) from shaft, and using suitable bearing press and adapters, press bearings off shaft.

4-15. CLEANING

Clean all parts in a suitable cleaning solvent being careful to observe all safety precautions regarding the use of solvent.

4-16. INSPECTION

4-17. Bearings. After cleaning, rotate bearings very slowly under hand pressure to feel for smoothness and even action. Never spin a dry bearing. Check for cracks, galling, pitting, burrs, etc. Replace bearing if there is any doubt concerning complete serviceability.

4-18. Drive Shaft. Inspect drive shaft (14) for scoring, burrs, cracks, etc. Replace as necessary.

4-19. Seals. It is sound practice to always replace grease seals (1 and 19) whenever drive shaft and tapered roller bearings are removed. Apply Locktite 690 to outside diameter of both grease seals.

4-20. Packing. It is sound practice to always replace packing (22) whenever the pump bearing housing is disassembled.

4.21. Rotor.

1. To check for excessive wear of rotor (40), measure the rotor crest-to-crest diameter (see fig. 4-4) and compare with the following chart:

Rotor Capacity	Standard *Crest to Crest Dia. (inches)
008	2.772 + .000/— .004
012	2.676 + .000/— .004
022	3.425 + .000/— .004
036	4.015 + .000/— .004
050	4.015 + .000/— .004
065	4.906 + .000/— .004
090	4.906 + .000/— .004
115	5.709 + .000/— .004
175	6.584 + .000/— .004
335	5.800 + .000/— .005
345	7.260 + .000/— .004
620	7.128 + .000/— .005
800	7.658 + .000/— .004

* These dimensions are applicable for AAA trim codes only.

Note: The rotor is designated by the third, fourth and fifth numbers in the Model Number, i.e., 1G065G1.

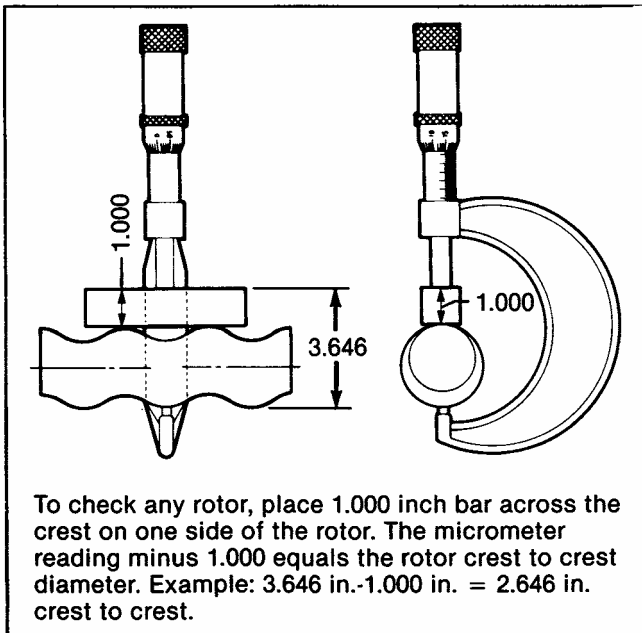

Figure 4-4. Measuring Rotor Dimension

2. If the measured crest to crest diameter is within 0.010 inch of the standard value and is free of deep nicks, gouges, or other surface defects, the rotor is re-usable.

3. Rotors with crest to crest values 0.011 to 0.050 inch under the standard values should be replaced. These rotors can be renewed by chrome plating to standard dimensions provided that:

a. The key slots are not excessively worn.

b. The rotor surface is not cracked, pitted or deeply grooved (1/32 inch or more).

c. The base surface metal is not pitted or corroded.

4. Rotors may be sent to Moyno or any other competent plating shop. Rotors should be stripped and replated to standard dimensions, then buffed.

4-22. Stator. A worn stator may appear pitted and gouged, or may appear smooth similar to when new. Performance is the best measure of rotor to stator fit. If unable to measure performance adequately, suspected stator wear can be evaluated by a Moyno sales or factory representative.

4-23. All Other Parts. Check for cracks, excessive wear, damage to threaded holes, burrs, etc. Replace as necessary. Replace O-rings and all gaskets at each disassembly and reassembly.

4-24. ASSEMBLY

The Moyno 2000 pumps are reassembled in the reverse order of dismantling. The following suggestions are offered:

1. While pump is dismantled, check all gaskets, seals, packing, and O-rings. Replace all worn items. It is recommended that the gear joint seals (13), gear joint O-ring (41), and drive shaft O-ring (5) be replaced each time either of the gear joints is disassembled.

2. During the assembly process, cleanliness is important. To avoid premature failure, bearings and gear joint components must be handled with care and kept clean.

4-25. Lubrication During Assembly

Note: The bearings are lubricated at the factory, and will only need to be re-lubricated when the shaft/bearing assembly is completely removed from pump.

1. Bearings. Pack bearings after installation on shaft (Section 4-28). Lubricant should be packed around all of the rollers and should completely cover the faces of the races. The void inside the spacer between the bearings should be filled approximately half way with lubricant.

2. Gear Joints. Both gear joints should be packed with lubricant during assembly (Sections 4-30 and 4-32). DO NOT use zerk fittings to lubricate gear joints after assembly. The pipe plugs (C) in the drive shaft head, drive shaft, and gear joint shell are vent plugs and MUST BE REMOVED during assembly of the gear joints to allow excess lubricant to vent from the gear joints.

3. Packing. Lubricate packing rings during assembly. Additional grease can be added after assembly through the zerk fittings installed in the side of the stuffing box.

4. Approved lubricants:

CAUTION: Do not mix different brands of lubricants for the same application.

Area to Lubricate	Approved Lubricant or Equivalent
Bearings, Gear Joints & Packing	ACG-2 (Dubois Chemical, Inc.)

4-26. Packing Installation

1. The standard packing set (22) consists of six braided packing rings. Lantern ring halves (23) must be ordered separately.

2. Install packing and lantern ring halves into the stuffing box area of the suction housing (29) in the following sequence:

- a. Wipe a film of lubricant on each packing ring and install two rings. Push each ring firmly in place.

Note: Install the packing rings with the splits staggered at 90 degrees to the adjacent ring of packing. On initial assembly, one ring of packing may not fit in stuffing box. This final ring of packing should be installed after pump is started and packing is seated.

CAUTION: Always use a proper packing tamper tool to install packing. Do not use a pointed or sharp tool, as damage to the packing material or drive shaft could result. To assure proper shaft lubrication, never use a one-piece spiral wrap packing.

- b. Install the two lantern ring halves with the flat side against the packing.

- c. Install final four packing rings, firmly pushing each ring into place.

3. Install packing gland studs (H), packing gland halves (21), and gland adjusting nuts (F). Tighten nuts finger tight at this time.

4-27. Bearing Housing/Suction Housing Assembly. This procedure may be performed now or after the bearing/drive shaft assembly is installed in the bearing housing.

1. Place clamp ring (28) on suction housing (29) and install retaining ring (27) in groove on suction housing.

2. Slide turned diameter of suction housing into bore on end of bearing housing (26). Align holes in clamp ring (28) with four threaded holes in bearing housing (26) and thread four hex head screws (0) with lock washers into threaded holes. Tighten finger tight.

3. Rotate suction flange to desired position (if not already fastened to piping) and tighten four hex head screws (0).

Note: Refer to Torque Guidelines Chart (page 12) for the proper torque requirement for all threaded fasteners.

4-28. Bearing/Drive Shaft Assembly

1. Bearings must be pressed on the shaft in the following sequence: [Larger units (G drive end and larger) require heating of the bearings to 250° F before assembly.]

- a. Press bearing cone on shaft (14), making sure rollers face in proper direction to receive cup (step b). Cone should be pressed firmly against shoulder on shaft.

- b. Place cup on rollers.

- c. Place bearing spacer (16) halves on cup.

- d. Place second cup on spacers.

- e. Press second bearing cone on shaft with rollers facing seat in cup. Cone should be pressed on until face of cone is flush or even with shoulder on shaft.

CAUTION: Do not press second cone past shoulder on shaft.

2. Thread bearing nut (18) on shaft (14) and tighten until it rests against the shoulder on the drive shaft. Install brass tip set screw (17) in bearing nut and tighten.

Note: The tapered bearings are designed such that when properly installed there may be a very slight end play in the bearings (bearing spacer halves may slip freely out of place) or they may have a slight pre-load (bearing spacer halves held tightly in place and bearings do not turn freely).

3. Remove bearing spacer halves (16). Thoroughly pack lubricant around rollers and on bearing races. Install one half of bearing spacer. Fill area between bearings half full of lubricant, and install other half of bearing spacer.

Note: Assuming the bearings are not too hot, an alternate method of lubricating bearings is as follows: Pack the rollers of the first cone immediately after it is pressed on shaft. Lubricate race of first cup before it is installed. Place bearing spacer halves in place and fill it full of lubricant. Lubricate race of second bearing cup and place on spacer. Pack rollers of second cone with lubricant, and press on shaft until flush with shoulder.

Note: If too much grease is packed into the bearings during assembly, it may seep from the grease seals during the first few hours of operation until the proper lubricant level is achieved. This lubricant should be wiped from the seal area, when the pump is not operating, to prevent contaminants from collecting in the seal area.

4. Install (light press) grease lip seals (1 and 19) into bearing cover plate (2) and bearing housing (26) with Loctite. The lip of the radial grease seal (1) should be facing outward with spring visible. The lip of the seal (19) should be facing the bearings. The lips of both seals should be wiped with grease.

5. Install drive shaft with bearings in bearing housing, being careful to avoid damaging the grease seal (19).

6. Place O-ring (3) on bearing cover plate and bolt bearing cover plate to bearing housing using six hex head screws (A) and lock washers. The six screws should be tightened evenly, and care should be taken to insure the O-ring becomes seated in the step in the bearing housing. When the bearing cover plate is fully secured to the bearing housing, a small gap of 0.010 to 0.020 inch will exist between the bearing cover plate and the bearing housing.

Note: Some pumps have a sleeve installed on the drive shaft to receive any possible wear caused by the packing. (See fig. 4-10.) If the sleeve is used, install at this time. Refer to Section 4-48 for details.

4-29. Rotor/Stator Assembly

1. Slide head ring (42) over rotor (40) contour to the rotor head. The side of the head ring with the smallest diameter holes should be facing the rotor head.

Note: On some models the head ring is a two-piece component which eliminates this step.

2. Slide stator clamp rings (36) on both ends of the stator (30) and secure in position with retaining rings (35).

3. On F012, G022, H036, H050 and K115 models, place one stator gasket (34) in recess of adapter flange (25A), and fit adapter flange with gasket to end of stator.

4. Coat the rotor (40) contour with waterless hand cleaner, glycol or other lubricant compatible with the stator elastomer. Insert rotor into stator so that rotor head is at the specified distance from the end of the stator (Dimension "A," fig. 4-5). On F012, G022, H036, and K115 models, be sure the rotor is inserted in the end of the stator fitted with the adapter flange (25A) and gasket (34).

Note: Rotor can also be inserted in the stator utilizing Moyno's Hydraulic Stator Removal Device (SRD). See separate SRD service manual or contact the local Moyno distributor for further [information on this new product](#).

Note: Turning the rotor counterclockwise while inserting into stator will ease assembly.

4-30. Rotor Gear Joint Assembly

1. Slip O-ring (41) over the rotor head and allow to hang loose with head ring. Insert primary thrust plate (6) into rotor head, flat side first. Thrust plate and rotor head surfaces must be flush to assure proper assembly and operation of the pump. (See fig. 4-6.)

2. Assemble the rotor end gear joint by first fitting a gear joint seal (13) onto the connecting rod assembly (38). The seal must be positioned so that the flat face of the seal neck fits into the seal retainer component of the connecting rod assembly. Apply a small coating of approved gear joint lubricant to the inside surfaces of the seal.

3. Apply a small amount of lubricant to the flat face of the seal support (12) and slide it onto the connecting rod so that the flat face and radius of the support is against the seal.

4. Grease the concave spherical surface of the rear thrust plate (11) and position thrust plate against the seal (13) with the lip on the outside diameter of the seal fitting the step on the back side of the thrust plate.

Frame Designation	A (inches)	Frame Designation	A (inches)
1E008G1	4.06	1H065G1	6.25
2E008G1	4.06	2H065G1	6.25
4E008G1	4.06	4H065G1	6.25
6E008G1	4.06	2H090G1	6.25
1E012G1, 1E018EG1	4.06	4H090G1	6.25
2E012G1, 2E018EG1	4.06	6H036G1	6.62
4E012G1	4.06	6H050G1	6.62
1E022G1, 1E033EG1	3.62	1H115G1	6.25
2E022G1, 2E033EG1	3.62	2H115G1	6.25
1E036G1	4.56	1H175G1	6.75
1F022G1	4.62	1J115G1	6.84
2F022G1	4.62	2J115G1	6.84
4F022G1	4.62	4J115G1	6.84
6F01231	5.00	6J065G1	6.84
1F036G1, 1F0543G1	4.00	6J090G1	6.84
2F036G1, 2F054EG1	4.00	1J175G1	7.00
1F050G1, 1F075EG1	4.00	2J175G1	7.00
2F050G1, 2F075EG1	4.00	1J335G1	7.19
4F050G1	4.00	1K175G1	8.70
1F065G1	4.75	2K175G1	8.70
1G036G1	5.68	4K175G1	8.70
2G036G1	5.68	6K115G1	9.20
4G036G1	5.68	1K335G1	8.70
4G050G1	5.68	2K335G1	8.70
6G050G1	5.68	3K335G1	8.75
6G022G1	6.06	1K345G1	8.75
1G065G1, 1G098EG1	6.06	2K345G1	8.75
2G065G1, 2G098EG1	6.06	3K345G1	8.75
1G090G1	6.06	1K620G1	8.75
2G090G1	6.06	2K620G1	8.75
1G115G1	6.19	1K800G1	7.50
		2K800G1	7.50

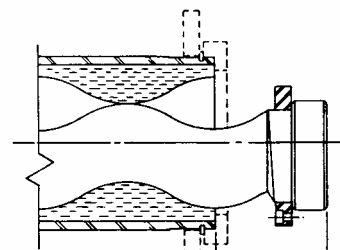

Fig. 4-5. Rotor Installation

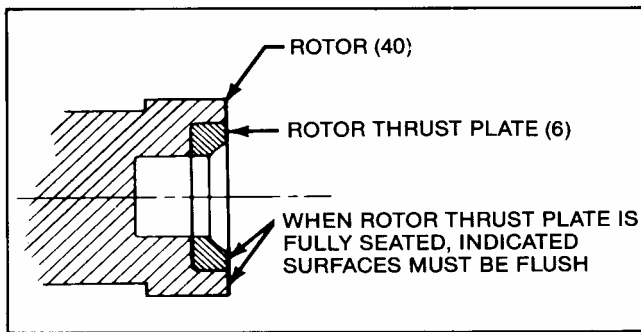

Figure 4-6. Rotor Thrust Plate Seating Detail

5. Apply a film of grease to the splines on the inside of the gear ball (10). Install gear ball on connecting rod (38), with counter-bored end (end without splines) first on connecting rod. Gear ball should slide freely against shoulder on connecting rod. Place lock nut (9) on connecting rod and tighten against gear ball. Apply grease to spherical surfaces and teeth of gear ball.

6. Apply grease to the teeth of the ring gear (8), and slide ring gear onto the gear ball. When ring gear is in place, keyways should be facing the lock nut end of connecting rod.

7. Apply a thin coating of grease to the spherical surface of the thrust plate (6) already installed in the rotor head. Fill the recessed area in the rotor head with grease.

8. Slide the gear joint shell (39) over the connecting rod and assembled gear joint components, being careful to seat the outside diameter of the gear joint seal (13) in the end of the gear joint shell (39). The two tapped holes in the gear joint shell should be in line with one of the keyways in the ring gear.

9. Place keys (7) in the keyways in the ring gear. Check to insure the tapped holes in the side of the gear joint shell are aligned with one of the keyways.

10. Align the keys in the ring gear with the keyways in the rotor head. Slide assembled gear joint shell onto the rotor head, checking to be sure the keys are properly engaged in the rotor head and ring gear. The shallow hole in the rotor head should be aligned with the first threaded hole in the outside of the gear joint shell. Thread the setscrew (S) into the threaded hole in the shell until light contact is made with the hole in the rotor head.

11. Place O-ring (41) into step in gear joint shell. Align holes in head ring (42) with six threaded holes in end of gear joint shell and install stainless socket head screws (T). Tighten the six socket head screws evenly, checking to insure O-ring (41) remains in place. When tightened properly, a small gap of a few thousandths of an inch may exist between the shell (39) and head ring (42).

12. Excess grease in the assembly will be purged from the vent hole while the socket head screws are tightened. Tighten the setscrew (S) in the shell. Move the free end of the connecting rod in a circular motion to assure that the joint is free and assembled properly. This will also help to purge excess grease from the assembly.

13. Install the stainless steel pipe plug (C) in the second hole in the shell and tighten.

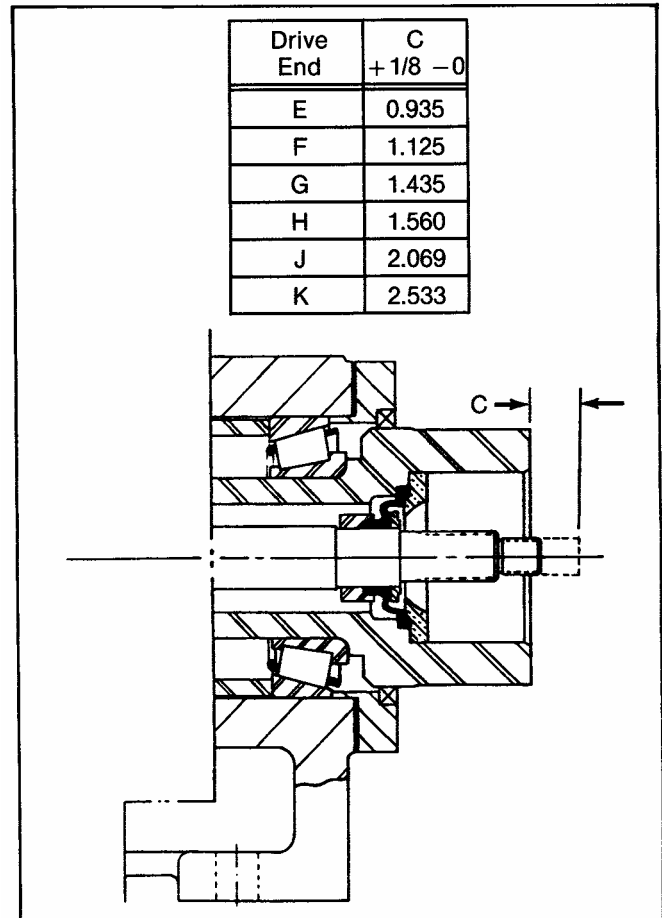

Figure 4-7. Gear Joint Installation

4-31. Rotor/Stator to Drive End Assembly

1. If not already in place, slip stator clamp rings (36) on both ends of stator (30), and install retaining rings (35) in grooves provided on both ends of stator.

2. Place stator gasket (34) in recess in end of suction housing:

a. On J335 model, stator gasket (34) will be installed in recess in adapter housing (25B).

b. On F012, G022, H036, and K115 models, stator gasket (34) will fit recess in adapter flange (25A) and adapter flange gasket (24A) will fit recess in suction housing.

3. Move the rotor/stator/connecting rod assembly in position, and insert connecting rod through the suction housing and drive shaft. Align stator with bore in suction housing, and slide stator in place, checking to insure that stator gasket (34) remains properly positioned.

4. Check the dimension "C" between the end of the connecting rod and face of the drive shaft as shown in fig. 4-7. For proper assembly of the drive end gear joint, this dimension should be no less than that shown in column C, and should not exceed the amount in column C by more than 1/8 inch. Reposition rotor/stator assembly in or out of suction housing as required to achieve the proper dimension.

5. If the stator is firmly seated against stator gasket in suction housing recess, and connecting rod extends beyond face of drive shaft by specified amount, stator may be secured to suction housing. If the specified dimension cannot be maintained with stator firmly seated, do not perform the following step 6 until the drive end gear joint is properly assembled.

6. Align holes in clamp ring (36A) with threaded holes in suction housing, and thread four hex head screws (R) with lockwashers through holes in clamp ring into threaded holes in suction housing. Tighten hex head screws evenly.

4-32. Drive End Gear Joint Assembly

1. Check to see that connecting rod extends beyond face of drive shaft by amount specified in column C of fig. 4-7. (See Section 4-31, step 4.)

2. Fit the gear joint seal (13) on the connecting rod (38). Push the seal firmly in place on the connecting rod so that the neck on the seal seats in the recess in the seal retainer component of the connecting rod.

3. Apply a film of gear joint grease to the inside of the gear joint seal and to the flat face of the seal support (12). Slide the seal support (12) onto the connecting rod such that the flat face fits against the seal.

4. Apply a film of grease to the concave spherical surface of the secondary thrust plate (11), and slowly push the thrust plate into the drive shaft until it rests firmly against the seal.

5. Apply a film of grease to the gear ball (10) splines and spherical surfaces, and install gear ball on connecting rod, counter-bored end first (end without splines). Gear ball should slide freely on rod until it contacts shoulder on rod. Install connecting rod lock nut (9) and tighten against gear ball. While tightening lock nut, prevent connecting rod from turning by carefully holding with pipe wrench or vise grips through inspection ports in suction housing.

6. Apply liberal amount of grease to gear ball teeth and ring gear (8) teeth, and slide ring gear into the drive shaft assembly. Keyways in ring gear should be facing out, and one of the keyways should be aligned with drilled and tapped holes in outside diameter of drive shaft.

7. Place keys (7) in keyways of the ring gear. A small amount of grease may be used to hold the keys in place. The flat face of the ring gear should be approximately flush with the face of the drive shaft.

8. Place primary thrust plate (6) in drive shaft head (4), aligning slot in outside diameter of thrust plate with pin in drive shaft head. When the thrust plate is properly seated, the face of the thrust plate should be flush with the face of the drive shaft head.

9. Lubricate the spherical surface of the thrust plate and fill the recess in the drive shaft head with grease.

10. Place O-ring (5) in the groove on drive shaft head (4). Align the keyways in the drive shaft head with the keys in the ring gear, and insert the head into the drive shaft assembly.

Note: If the threaded holes in the drive shaft do not align with the holes in the drive shaft head, a strap wrench or pipe wrench may be used to turn the drive shaft slightly.

11. Thread the six socket head screws (E) through the drive shaft head into the drive shaft. Tighten them evenly until face of drive shaft head is tight against face of drive shaft. Excess grease in the gear joint assembly will be purged from the holes in the drive shaft and drive shaft head.

Note: If the standard socket head screws are not long enough initially to engage the threads in the drive shaft, two longer screws may be used 180 degrees apart to pull the drive shaft head close enough to the drive shaft to engage the standard screws.

12. After the six socket head screws (E) are secured and the grease has been purged from the assembly, install the pipe plugs (C) in the drive shaft head and drive shaft. Also install the locking set screw (D) in the drive shaft in the threaded hole nearest the bearing housing.

13. If the stator was not previously tightened to the suction housing (Section 4-31, step 5), it should be tightened at this time.

4-33. Stator Support/Discharge Assembly

1. Place top of stator support(s) (31) over stator and fasten to bottom half of stator supports using hex head screws (L).

2. Place stator gasket (34) in recess in discharge flange (37) and position discharge flange on end of stator. Align holes in stator clamp ring (36B) with threaded holes in discharge flange, and install and tighten hex head screws (M).

4-34. Final Assembly

1. Install inspection plates (32) to suction housing (29) with gaskets (33), using hex head screws (P) and lockwashers.

2. Install pipe plugs (Q and J) and zerk fittings (K) in appropriate threaded holes in suction housing. Install pipe plugs (N) in threaded holes in bearing housing, or attach drain lines if preferred.

3. Connect power source. Turn on flush water to packing if used. Open suction and discharge valves, and start pump.

4-35. Packing Adjustment

For packing adjustment, refer to Section 4-3.

4-36. STORAGE

4-37. Short Term Storage. Storage of 6 months or less will not damage the pump. However, to insure the best possible protection, the following is advised:

1. Store pump inside whenever possible or cover with some type of protective covering. Do not allow moisture to collect around pump.

2. Remove drain plug and inspection plates to allow the pump body to drain and dry completely. Replace inspection plates.

3. Loosen the packing gland and inject a liberal amount of grease into the stuffing box. Tighten the gland nuts only hand tight. When water flush systems are to be used, do not use grease. A small amount of light oil is recommended.

4. See drive manufacturer's instructions for motor and/or drive storage.

5. See OPERATION Sections 3-1 through 3-4 before startup. Be sure all lubricants are in good condition.

4-38. Long Term Storage. If pump is to be in storage for more than 6 months, perform the above short term storage procedures plus the following:

1. Occasionally rotate the pump manually a few revolutions to avoid a "set" condition of rotor in stator elastomer. This will prevent hard starting and excessive torque requirements when pump is again put into operation.
2. Apply rust inhibitor to all unpainted cast iron and machined carbon steel surfaces.
3. Remove drive belts if applicable.

4-39. PACKING SPECIFICATION

Standard packing on all Moyno 2000 pumps consists of braided PTFE fibers impregnated with ultra-fine graphite. Optional types of packing are available for food, high temperature and other types of service. Consult your nearest Moyno representative.

4-40. VARIATIONS OF STANDARD PARTS

The following are variations available for modifying pumps to meet specialized pumping conditions. If the trim code of your pump is other than "AAA," contact your nearest Moyno representative for clarification. Do not modify your pump with any variation unless you have determined that it is compatible with your application.

The three-character trim code is designed as follows. The first character identifies any sealing variations, the second character identifies any internal variations, and the third character identifies any rotor variations.

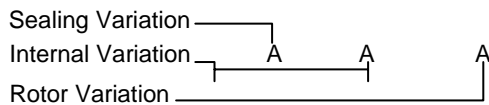

The trim code "AAA" represents a pump with standard features. Deviations from standard are to be indicated by changing the appropriate character from the choices listed. When two or more letters are combined, dashes are used to separate the three areas of the trim code for clarity.

SEALING VARIATIONS

- A — BRAIDED TEFLON & GRAPHITE PACKING, (Black) Standard to all lines except Quick Disassembly pumps. Optional on Quick Disassembly pumps.
- C — BRAIDED TEFLON PACKING, (White) Optional packing on all lines.
- D — DOUBLE MECHANICAL SEAL, Optional on all lines. Not offered on #2 "L" frame.
- F — BRAIDED TEFLON FOOD GRADE PACKING, (White) Standard on all Quick Disassembly pumps. Optional on all other lines.
- G — 100% GRAPHITE PACKING, (Gray) Optional to all lines.
- H — FLUSH PACKING GLAND
- S — SINGLE MECHANICAL SEAL, Optional on all lines.
- W — WATER FLUSH, Optional on all lines.
- X — Special to application

INTERNAL VARIATIONS

- A — Standard plated shaft
- B — Non-plated shaft
- C — Solid drive shaft configuration
- E — Extension tube with extended auger
- F — Extended drive shaft (for back stop or large pulley)
- G — Ceramic coated drive shaft
- K — Tungsten carbide coated drive shaft
- M — Chromium carbide coated drive shaft
- R — Fiber deflector
- S — Shaft sleeve
- X — Special to application

ROTOR VARIATIONS

- A — Standard size with chrome plating
- B — Non-plated (no plating)
- C — Standard undersize
- E — Standard oversize
- G — Ceramic coating
- K — Tungsten carbide coating
- M — Chromium carbide coating
- X — Special to application

4-41. Rotors identified on parts listing are standard size with hard chrome plated surface. Other variations of rotor size and finish may be ordered by selecting the standard rotor part number and changing the last digit of the rotor number as follows:

- 2 = Standard size, non-plated
- 3 = Undersize, chrome-plated
- 4 = Undersize, non-plated
- 5 = Oversize, chrome-plated

Do not change rotor sizes without consulting your local Moyno Sales Office. These variations are used for certain specialized pumping conditions only.

4-42. Drive Shafts shown have hard-chrome plating on the packing wear area. If non-plated drive shafts are required, select the standard part number and change the last digit to next higher number; example: PE0261 to PE0262. If the optional shaft sleeve is used, refer to Table 4-13 and 4-14 for appropriate part numbers.

TORQUE GUIDELINES CHART

Stainless Steel Bolts		Carbon Steel Bolts	
Size	Max. Torque	Size	Max. Torque
N0. 10-24	22.8 in. lb.	5/16-18	10 ft. lb.
1/4-20	75.2 in. lb.	3/8-16	21.7ft. lb.
5/16-18	132 in. lb.	1/2-13	43.5ft. lb.
3/8-16	236 in. lb.	5/8-11	86 ft. lb.
1/2-13	517 in. lb.	3/4-10	152 ft. lb.

Connecting Rod Lock Nuts		
Drive End	Nut Size	Max. Torque
E	9/16-18	25ft.lb.
F	3/4-16	35 ft. lb.
G,H	7/8-14	50ft.lb.
J	1 1/4-12	85 ft. lb.
K	1 1/2-12	110 ft. lb.

Note: Torque values are from the Industrial Fasteners Institute and Craftsman Corp.

4-43. STANDARD HARDWARE

Ref. No.	Description	Drive End											
		E	Qty	F	Qty	G	Qty	H	Qty	J	Qty	K	Qty
A	Hex Head Screw Lock Washer	3/8-16 x 1-3/4	6	1/2-13 x 1-3/4	6	1/2-13 x 2	6	5/8-11 x 2	6	5/8-11 x 2-1/4	6	3/4-10 x 2-3/4	8
		3/8	6	1/2	6	1/2	6	5/8	6	5/8	6	3/4	8
B	Shaft Key	1/2 x 1/2 x 3-3/4	1	1/2 x 1/2 x 3-3/4	1	5/8 x 5/8 x 3-1/2	1	3/4 x 3/4 x 3-1/4	1	7/8 x 7/8 x 4-1/4	1	1 x 1 x 4	1
C	Pipe Plug (stainless steel)	1/8 NPT	3	1/8 NPT	3	1/8 NPT	3	1/8 NPT	3	1/8 NPT	3	1/8 NPT	3
D	Set Screw (with thread sealing compound)	Not Required		5/16-18 x 3/4	1	3/8-16 x 1	1	3/8-16 x 1	1	3/8-16 x 1	1	3/8-16 x 1	1
E	Socket Head Screw	3/8-16 x 3/4	6	1/2-13 x 1	6	1/2-13 x 1-1/4	6	5/8-11 x 1-1/4	6	3/4-10 x 1-1/2	6	3/4-10 x 1-1/2	6
F	Hex Nut, Packing	3/8-16	2	3/8-16	2	1/2-13	2	5/8-11	2	5/8-11	2	3/4-10	2
G	Hex Head Screw Lock Washer	Not Required		Not Required		Not Required		Not Required		J335 3/4-10 x 2-3/4	8	Not Required	
H	Stud, Packing	3/8-16 x 2-1/2	2	3/8-16 x 2-1/2	2	1/2-13 x 3-1/2	2	5/8-11 x 4	2	5/8-11 x 4	2	3/4-10 x 4-1/2	2
J	Pipe Plug	1/8 NPT	1	1/8 NPT	1	1/8 NPT	1	1/8 NPT	1	1/8 NPT	1	1/8 NPT	1
K	Zerk Fitting	1/8 NPT	1	1/8 NPT	1	1/8 NPT	1	1/8 NPT	1	1/8 NPT	1	1/8 NPT	1
L	Hex Head Bolt	E008G1, E012G1, E022G1	4	F012G1, F022G1	6	G022G1, H115G1, H175G1	4	H065G1, H090G1, H115G1, H175G1	6	J065G1, J090G1, J115G1, J175G1, J335G1, J220	6	K115G1, K175G1, K335G1, K345G1	2
		5/8-11 x 3-1/4	4	5/8-11 x 3-1/4	6	5/8-11 x 3-1/4	4	3/4-10 x 4-1/2	6	3/4-10 x 4-1/2	6	5/8-11 x 4	2
	Hex Head Bolt	E036G1, E050G1	2	F036G1, F050G1	4	G036G1, G050G1	6	H065G1, H090G1	6	J065G1, J090G1	6	K115G1, K175G1	2
		3/4-10 x 3-1/2	2	3/4-10 x 3-1/2	4	3/4-10 x 3-1/2	6	3/4-10 x 3-1/2	6	3/4-10 x 3-1/2	6	5/8-11 x 4	2
	Hex Head Bolt	F065G1, F090G1	2	G065G1, G090G1, G115G1	2	H065G1, H090G1, G115G1	2	J065G1, J090G1, G115G1	2	K115G1, K175G1, K335G1, K345G1	2	5/8-11 x 4	2
		3/4-10 x 4-1/2	2	3/4-10 x 4-1/2	2	3/4-10 x 4-1/2	2	3/4-10 x 4-1/2	2	3/4-10 x 4-1/2	2	5/8-11 x 4	2
M	Hex Head Screw Lock Washer	1 & 2E008G1, 1 & 2E012G1, 1, 2 & 4E022G1	4	1 & 2F022G1	4	1 & 2G036G1, 1 & 2G050G1	4	1 & 2H065G1, 1 & 2H090G1, 2 & 4H115G1	6	1 & 2J115G1	6	1 & 2K175G1, 1K335G1, 1K345G1	8
		5/8-11 x 1-1/2	4	5/8-11 x 1-1/2	4	3/4-10 x 1-3/4	4	3/4-10 x 2	6	3/4-10 x 2	6	3/4-10 x 2	8
	Hex Head Screw Lock Washer	1 & 2E050G1, 4E012G1	8	1 & 2F090G1, 4 & 6F022G1	12	1 & 2G115G1, 6G022G1, 6G036G1, 6G050G1	12	6H036G1, 6H050G1, 4 & 6H065G1, 4 & 6H090G1	12	6J065G1, 6J090G1, 4 & 6J115G1	12	6K115G1, 4K175G1, 2 & 3K335G1, 2 & 3K345G1	12
		3/4-10 x 1-3/4	8	3/4-10 x 2	12	3/4-10 x 2	12	3/4-10 x 2	12	3/4-10 x 2	12	3/4-10 x 2-1/2	12
	Hex Head Screw Lock Washer	3/4	8	3/4	12	3/4	12	3/4	12	3/4	12	3/4	12
		3/4-10 x 1-3/4	4	3/4-10 x 1-3/4	4	3/4-10 x 2	6	3/4-10 x 2	8	3/4-10 x 2	8	7/8-9 x 2-1/2	12
	Hex Head Screw Lock Washer	1 & 2E036G1	4	1, 2 & 4F036G1, 1, 2 & 4F050G1	4	4G036G1, 4G050G1, 1 & 2G090G1	6	1 & 2H175G1	8	1 & 2J345G1, 1 & 2J175G1, 1 & 2J335G1	8	1 & 2K800	12
		3/4-10 x 1-3/4	4	3/4-10 x 1-3/4	4	3/4-10 x 2	6	3/4-10 x 2	8	3/4-10 x 2	8	7/8-9 x 2-1/2	12
	Hex Head Screw Lock Washer	3/4	4	3/4	4	3/4	6	3/4	8	3/4	8	7/8	12
		3/4-10 x 1-3/4	4	3/4-10 x 1-3/4	4	3/4-10 x 2	6	3/4-10 x 2	8	3/4-10 x 2	8	7/8-9 x 2-1/2	12
	Hex Head Screw Lock Washer	6F012G1	8	3/4-10 x 2	8	3/4	8	J220	8	3/4-10 x 2	8	3/4	8
		3/4-10 x 2	8	3/4	8	3/4	8	3/4	8	3/4	8	3/4	8
	Hex Head Screw Lock Washer	1 & 2F065G1	6	3/4-10 x 2	6	3/4	6	3/4	6	3/4	6	3/4	6
		3/4-10 x 2	6	3/4	6	3/4	6	3/4	6	3/4	6	3/4	6
N	Pipe Plug	3/4 NPT	2	3/4 NPT	2	3/4 NPT	2	3/4 NPT	2	3/4 NPT	2	3/4 NPT	2
O	Hex Head Screw Lock Washer	5/8-11 x 1-3/4	4	3/4-10 x 2	4	3/4-10 x 2	6	3/4-10 x 2	6	3/4-10 x 2-1/4	6	3/4-10 x 2-1/2	8
		5/8	4	3/4	4	3/4	6	3/4	6	3/4	6	3/4	8
P	Hex Head Screw Lock Washer	5/16-18 x 1	16	3/16 x 1	16	3/8-16 x 1	16	3/8-16 x 1	16	1/2-13 x 1-1/4	16	1/2-13 x 1-1/4	16
		5/16	16	3/8	16	3/8	16	3/8	16	1/2	16	1/2	16
Q	Pipe Plug	3/4 NPT	1	3/4 NPT	1	3/4 NPT	1	3/4 NPT	1	3/4 NPT	1	3/4 NPT	2
		3/4 NPT	1	3/4 NPT	1	3/4 NPT	1	3/4 NPT	1	3/4 NPT	1	3/4 NPT	2
R	Hex Head Screw Lock Washer	E008G1, E012G1, E022G1	4	F012G1	4	G022G1	4	H036G1, H050G1	6	J065G1, J090G1, J115G1	6	K175G1, K335G1, K345G1	8
		5/8-11 x 1-1/2	4	5/8-11 x 2	4	3/4-10 x 2-1/2	4	3/4-10 x 2-1/2	6	3/4-10 x 2	6	3/4-10 x 2-1/2	8
	Hex Head Screw Lock Washer	5/8	4	5/8	4	3/4	4	3/4	6	3/4	6	3/4	8
		3/4-10 x 2	4	5/8-11 x 1-1/2	4	3/4-10 x 2	4	3/4-10 x 2	6	3/4-10 x 2	6	3/4-10 x 2-3/4	8
	Hex Head Screw Lock Washer	E036G1	4	F022G1	4	G036G1, G050G1	4	H065G1, H090G1, H115G1	6	J175G1, J335G1, J345G1	6	K115G1	8
		3/4	4	5/8	4	3/4	4	3/4	6	3/4	6	3/4	8
	Hex Head Screw Lock Washer	F036G1, F050G1	4	G065G1, G090G1	4	H065G1, H090G1	6	H175G1	8	J220	8	1 & 2K800	12
		3/4-10 x 2-1/4	4	3/4-10 x 2-1/4	4	3/4-10 x 2	6	3/4-10 x 2	8	3/4-10 x 2	8	7/8-9 x 3	12
	Hex Head Screw Lock Washer	F065G1	6	3/4-10 x 2-1/4	6	3/4	6	3/4	8	3/4	8	7/8	12
		3/4-10 x 2-1/4	6	3/4	6	3/4	6	3/4	8	3/4	8	7/8	12
S	Set Screw (stainless steel with thread sealing compound)	5/16-18 x 5/8	1	5/16-18 x 5/8	1	5/16-18 x 5/8	1	5/16-18 x 5/8	1	3/8-16 x 3/4	1	3/8-16 x 3/4	1
T	Socket Head Screw	10-24 x 1/2	6	1/4-20 x 5/8	6	1/4-20 x 3/4	6	5/16-18 x 3/4	6	3/8-16 x 1	6	1/2-13 x 1-1/4	6
U	Set Screw	5/16-18 x 1/4	4	5/16-18 x 1/4	4	5/16-18 x 1/4	4	5/16-18 x 1/4	6	5/16-18 x 3/8	6	5/16-18 x 3/8	6

4-44. SELECTING THE CORRECT PART FOR YOUR MOYNO 2000 PROGRESSING CAVITY PUMP

PUMP MODEL DESIGNATION

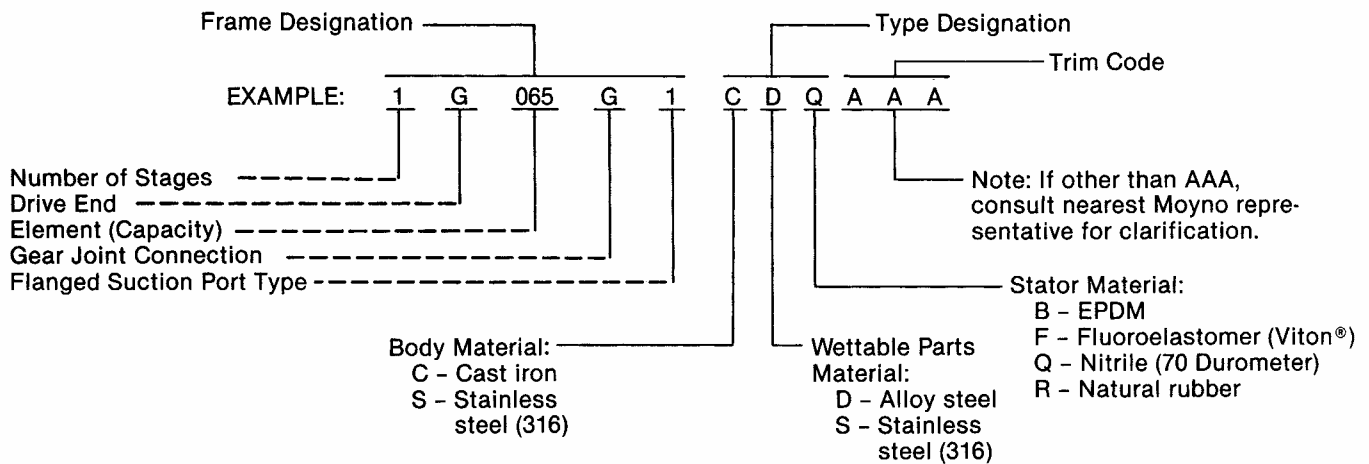

- Table 4-1** (Page 15) **Basic Drive End Parts:** Select Reference Number part by Drive End (1G065G1 CDQ AAA) and Type Designation (1G065G1 CDQ AAA) where listed.
- Table 4-2** (Page 16) **Wettable Castings (CD & CS):** Select Reference Number part by Drive End and Element (1G065G1 CDQ AAA) if Type Designation begins with CD or CS (1G065G1 CDQ AAA).
- Table 4.3** (Page 17) **Wettable Castings (SS):** Select Reference Number part by Drive End and Element (1G065G1 SSQ AAA) if Type Designation begins with SS (1G065G1 SSQ AAA).
- Table 4-4** (Page 17) **Stators:** Select Stator part number by Drive End and Element (1G065G1 CDQ AAA), and number of stages (1G065G1 CDQ AAA). The last letter of the Type Designation (1G065G1 CDQ AAA) must be added as the sixth digit of the part number.
- Table 4-5** (Page 18) **Stator Gaskets:** Select Stator Gasket part number by Drive End and Element (1G065G1 CDQ AAA), and Type Designation (1G065G1 CDQ AAA).
- Table 4-6** (Page 18) **Stator Clamp Rings:** Select Stator Clamp Ring part number by Drive End and Element (1G065G1 CDQ AAA), and number of stages (1G065G1 CDQ AAA).
- Table 4-7** (Page 19) **Connecting Rods:** Select Connecting Rod part number by Drive End and Element (1G065G1 CDQ AAA), and Type Designation (1G065G1 CDQ AAA).
- Table 4-8** (Page 19) **Discharge Flanges (CD):** Select Discharge Flange part number by Drive End and Element (1G065G1 CDQ AAA), and number of stages (1G065 CDQ AAA), if Type Designation begins with CD.
- Table 4-9** (Page 20) **Discharge Flanges (CS & SS): Select Discharge Flange** part number by Drive End and Element (1G065G1 CSQ AAA), and number of stages (1G065 CSQ AAA), if Type Designation begins with CS or SS.
- Table 4-10** (Page 20) **Rotors (CD):** Select Rotor part number by Drive End and Element (1G065G1 CDQ AAA), and number of stages (1G065 CDQ AAA), if Type Designation begins with CD.
- Table 4-11** (Page 22) **Rotors (CS & SS):** Select Rotor part number by Drive End and Element (1G065G1 CSQ AAA), and number of stages (1G065 CSQ AAA), if Type Designation begins with CS or SS.
- Table 4-12** (Page 22) **Head Rings:** Select Head Ring part number by Drive End and Element (1G065G1 CDQ AAA), and Type Designation (1G065G1 CDQ AAA).
- Table 4-13** (Page 21) **Shaft Sleeve (CD):** Select Reference Number part by Drive End and Element (1G065 CDQ AAA) if Type Designation begins with CD (Shaft Sleeve Option only).
- Table 4-14** (Page 21) **Shaft Sleeve (CS & SS):** Select Reference Number part by Drive End and Element (1G065 CSQ AAA) if Type Designation begins with CS or SS (Shaft Sleeve Option only).

		DRIVE END SIZE					
REF. NO.	DESCRIPTION	E	F	G	H	J	K
1	Radial Grease Seal	AG0611	PF0611	PG0611	PH0611	PJ0611	PK0611
2	Bearing Cover Plate	PE0341	PF0341	PG0341	PH0341	PJ0341	PK0341
3	O-Ring	PE110Q	BJ112Q	BK113Q	PH110Q	BH114Q	PK110Q
4	Drive Shaft Head	PE0971	PF0971	PG0971	PH0971	PJ0971	PK0971
5	O-Ring Shaft Head:	BE111Q	BE113Q	BG114Q	BH111Q	TJ111Q	BK114Q
6	Primary Thrust Plate	PE0981	PF0981	PG0981	PH0981	PJ0981	PK0981
7	Key	RE0761	RF0761	RG0761	RH0761	RJ0761	RK0761
8	Ring Gear	AE0952	AF0952	AG0952	AH0952	AJ0952	AK0952
9	Lock Nut	RE0581	RF0581	RG0581	RH0581	RJ0581	RK0581
10	Gear Ball	AE0951	AF0951	AG0951	AH0951	AJ0951	AK0951
	Gear Joint Kit (See Note C)	KPE951	KPF951	KPG951	KPH951	KPJ951	KPK951
11	Secondary Thrust Plate	PE0982	PF0982	PG0982	PH0982	PJ0982	PK0982
12	Seal Support	PE0891	PF0891	PG0891	PH0891	PJ0891	PK0891
13	Gear Joint Seal:						
	CDQ, CSQ, SSQ, CDR, CSR, SSR	PE087Q	PF087Q	PG087Q	PH087Q	PJ087Q	PK087Q
	CDB, CSB, SSB, CDF, CSF, SSF	PE087F	PF087F	PG087F	PH087F	PJ087F	PK087F
	Gear Joint Seal Kit (See Note D):						
	CDQ, CSQ, SSQ, CDR, CSR, SSR	KPE87Q	KPF87Q	KPG87Q	KPH87Q	KPJ87Q	KPK87Q
	CDB, CSB, SSB, CDF, CSF, SSF	KPE87F	KPF87F	KPG87F	KPH87F	KPJ87F	KPK87F
14	Drive Shaft:						
	CDQ, CDR, CDB, CDF	PE0261	PF0261	PG0261	PH0261	PJ0261	PK0261
	CSQ, CSR, CSB, CSF, SSQ, SSR, SSB, SSF	PE0266	PF0266	PG0266	PH0266	PJ0266	PK0266
15	Tapered Roller Bearing	PE0311	PF0311	PG0311	PH0311	PJ0311	PK0311
	Bearing Kit (See Note B)	KPE291	KPF291	KPG291	KPH291	KPJ291	KPK291
16	Bearing Spacer	PE0331	PF0331	PG0331	PH0331	PJ0331	PK0331
17	Bearing Lock Plug	P10762	P10762	P10762	P10762	P10762	P10762
18	Bearing Lock Nut	PE0581	PF0581	PG0581	PH0581	PJ0581	PK0581
19	Thrust Grease Seal	AK0621	XK0621	PG0621	PH0621	AI4611	PK0621
20	Slinger Ring	PE0771	PF0771	PG0771	PH0771	PJ0771	PK0771
21	Packing Gland Half (See Note A):						
	CDQ, CDR, CDB, CDF, CSQ, CSR, CSB, CSF	PE041D	PF041D	PG041D	PH041D	PJ041D	PK041D
	SSQ, SSR, SSB, SSF	PE041S	PF041S	PG041S	PH041S	PJ041S	PK041S
22	Packing (See Note A)	PE0423	PF0423	PG0423	PH0423	PJ0423	PK0423
23	Lantern Ring Half (See Note A)	AE0571	PF0571	PG0571	PH0571	AJ0571	PK0571
24A	Adapter Gasket:						
	CDB, CSB, SSB	----	BF085B	BG085B	BH085B	----	BK085B
	CDQ, CDR, CSQ, CSR, SSQ, SSR	----	BF085Q	BG085Q	BH085Q	----	BK085Q
	CDF, CSF, SSF	----	BF085F	BG085F	BH085F	----	BK085F
24B	Adapter Gasket:						
	CDB, CSB, SSB	----	----	----	----	BK085B	----
	CDQ, CDR, CSQ, CSR, SSQ, SSR	----	----	----	----	BK085Q	----
	CDF, CSF, SSF	----	----	----	----	BK085F	----
25A	Adapter Bushing—See Tables 4-2 and 4-3						
25B	Adapter Bushing—See Tables 4-2 and 4-3						
26	Bearing Housing	PE0051	PF0051	PG0051	PH0051	PJ0051	PK0051
27	Retaining Ring	AF0085	AG0085	PG0085	AH0085	PJ0085	PK0085
28	Clamp Ring	AF0932	AG0932	PG0932	AH0932	PJ0932	PK0932
29	Suction Housing—See Tables 4-2 and 4-3						
30	Stator—See Table 4-4						
31	Stator Support—See Tables 4-2 and 4-3						
32	Inspection Plate:						
	CDQ, CDR, CDB, CDF, CSQ, CSR, CSB, CSF	BE0171	BF0171	BF0171	BF0171	BH0171	BJ0171
	SSQ, SSR, SSB, SSF	BE0176	BF0176	BF0176	BF0176	BH0176	BJ0176
	-K800 CDQ, CDR, CDB, CDF, CSQ, CSR, CSB, CSF	----	----	----	----	----	BJ0172
	SSQ, SSR, SSB, SSF	----	----	----	----	----	BJ0177
33	Inspection Plate Gasket:						
	CDB, CSB, SSB	BE079B	BF079B	BF079B	BF079B	BH079B	BJ079B
	CDQ, CDR, CSQ, CSR, SSQ, SSR	BE079Q	BF079Q	BF079Q	BF079Q	BH079Q	BH079Q
	CDF, CSF, SSF	BE079F	BF079F	BF079F	BF079F	BH079F	BH079F
34	Stator Gasket—See Table 4-5						
35	Retaining Ring—See Tables 4-2 and 4-3						

4-45. PARTS LIST (Cont.)

Table 4-1. Parts List (Cont.)

REF. NO.	DESCRIPTION	DRIVE END SIZE					
		E	F	G	H	J	K
36A	Stator Ring Clip—See Table 4-6						
36B	Stator Clamp Ring—See Table 4-6						
37	Discharge Flange—See Table 4-8						
38	Connecting Rod—See Table 4-7						
39	Gear Joint Shell:						
	CDQ, CDR, CDB, CDF	PE0911	PF0911	PG0911	PH0911	PJ0911	PK0911
	CSQ, CSR, CSB, CSF, SSQ, SSR, SSB, SSF	PE0916	PF0916	PG0916	PH0916	PJ0916	PK0916
40	Rotor—See Tables 4-10 and 4-11						
41	O-ring:						
	CDQ, CDR, CSQ, CSR, SSQ, SSR ..	PE113Q	PF113Q	PG113Q	PH113Q	PJ113Q	PK113Q
	CDB, CSB, SSB	PE113B	PF113B	PG113B	PH113B	PJ113B	PK113B
	CDF, SCF, SSF	PE113F	PF113F	PG113F	PH113F	PJ113F	PK113F
42	Head Ring—See Table 4-12						
43	Shaft Sleeve Kit—See Table 4-13						

Note A: For pumps with shaft sleeve, see pages 21, 24 and 25.

Note B: Bearing Kit includes items 1, 15(2), 19.

Note C: Gear Joint Kit includes items 6, 7(2), 8, 10, 11, 12.

Note D: Gear Joint Seal Kit includes items 5, 13, 41.

Table 4-2. Parts List —Type Designation Begins with CD or CS

REF. NO. →	25A ADAPTOR BUSHING	25B STATOR ADAPTOR	29 SUCTION HOUSING	31 STATOR SUPPORT	35 RETAINING RING (2)
E008	----	----	PE0021	BE0381	AE0085
E012, E018E	----	----	PE0021	BE0381	AE0085
E022, E033E	----	----	PE0022	BE0382	AF0085
E036	----	----	PE0031	PE0381	AG0085
E050	----	----	PE0031	PE0381	AG0085
F012	BF0511	----	PF0021	BF0383	AE0085
F022	----	----	PF0021	BF0381	AF0085
F036, F054E	----	----	PF0022	BF0382	AG0085
F050, F075E	----	----	PF0022	BF0382	AG0085
F065	----	----	PF0031	PF0381	AH0085
F090	----	----	PF0031	PF0381	AH0085
G022	BG0511	----	PG0021	BG0383	AF0085
G036	----	----	PG0021	BG0381	AG0085
G050	----	----	PG0021	BG0381	AG0085
G065, G098E	----	----	PG0022	BG0382	AH0085
G090	----	----	PG0022	BG0382	AH0085
G115	----	----	PG0031	BG0382	AH0085
H036	BH0511	----	PH0021	BH0382	AG0085
H065	----	----	PH0021	BH0381	AH0085
H090	----	----	PH0021	BH0381	AH0085
H115	----	----	PH0021	BH0381	AH0085
H175	----	----	PH0031	BJ0381	AK0084
J065	----	PJ0511	PJ0021	BH0381	AH0085
J090	----	----	PJ0021	BH0381	AH0085
J115	----	----	PJ0021	BH0381	AH0085
J175, J220	----	----	PJ0022	BJ0381	AK0084
J335	----	----	PJ0022	BH0381	AK0084
J345	----	----	PJ0022	BH0381	AK0084
K115	BK0511	----	PK0021	BK0382	AH0085
K175	----	----	PK0021	BK0381	AK0084
K335	----	----	PK0021	BK0381	AK0084
K345	----	----	PK0021	BK0381	AK0084
K620	----	----	PK0021	BK0381	AK0084
K800	----	----	PK0022	BK0383	AK0085

Table 4-3. Parts List —Type Designation Begins with SS

REF. NO: →	25A ADAPTOR BUSHING	25B STATOR ADAPTOR	29 SUCTION HOUSING	31 STATOR SUPPORT	35 RETAINING RING (2)
E008	----	----	PE0026	BE0381	AE0085
E012, E018E	----	----	PE0026	BE0381	AE0085
E022, E033E	----	----	PE0027	BE0382	AF0085
E036	----	----	PE0032	BE0381	AG0085
E050	----	----	PE0032	BE0381	AG0085
F012	BF0516	----	PF0026	BF0383	AE0085
F022	----	----	PF0026	BF0381	AF0085
F036, F054E	----	----	PF0027	BF0382	AG0085
F050, F075E	----	----	PF0027	BF0382	AG0085
F065	----	----	PF0032	PF0381	AH0085
F090	----	----	PF0032	PF0381	AH0085
G022	BG0516	----	PG0026	BG0383	AF0085
G036	----	----	PG0026	BG0381	AG0085
G050	----	----	PG0026	BG0381	AG0085
G065, G098E	----	----	PG0027	BG0382	AH0085
G090	----	----	PG0027	BG0382	AH0085
G115	----	----	PG0032	BG0382	AH0085
H036	BH0516	----	PH0026	BH0382	AG0085
H065	----	----	PH0026	BH0381	AH0085
H090	----	----	PH0026	BH0381	AH0085
H115	----	----	PH0026	BH0381	AH0085
H175	----	----	PH0032	BJ0381	AK0084
J065	----	----	PJ0026	BH0381	AH0085
J090	----	----	PJ0026	BH0381	AH0085
J115	----	----	PJ0026	BH0381	AH0085
J175, J220	----	----	PJ0027	BJ0381	AK0084
J335	----	PJ0516	PJ0027	BH0381	AK0084
J345	----	----	PJ0032	BH0381	AK0084
K115	BK0516	----	PK0026	BK0382	AH0084
K175	----	----	PK0026	BK0381	AK0084
K335	----	----	PK0026	BK0381	AK0084
K345	----	----	PK0026	BK0381	AK0084
K620	----	----	PK0026	BK0381	AK0084
K800	----	----	PK0027	BK0383	AK0085

Table 4-4. Stator (Ref. No. 30) Part Number

MODEL	STAGES					
	1	2	3	4	6	9
E008	C3108†	C3208†	----	C3408†	C3608†	----
E012	C310E†	C320E†	----	C340E†	C360E†	----
E018E	E3118†	E3218†	----	----	----	----
E022	C310F†	C320F†	----	C340F†	----	----
E033E	E3133†	E3233†	----	----	----	----
E036	C310G†	C320G†	----	----	----	----
E050	C3150†	C3250†	----	----	----	----
F012	----	----	----	----	C360E†	C390E†
F022	C310F†	C320F†	----	C340F†	C360F†	----
F036	C310G†	C320G†	----	C340G†	----	----
F050	C3150†	C3250†	----	C3450†	----	----
F054E	E3154†	E3254†	----	----	----	----
F065	C310H†	C320H†	----	----	----	----
F075E	E3175†	E3275†	----	----	----	----
F090	C3190†	C3290†	----	----	----	----
G022	----	----	----	----	C360F†	C390F†
G036	C310G†	C320G†	----	C340G†	C360G†	----
G050	----	C3250†	----	C3450†	C3650†	----
G065	C310H†	C320H†	----	C340H†	----	----
G090	C3190†	C3290†	----	C3490†	----	----
G098E	E3198†	E3298†	----	----	----	----
G115	C310J†	C320J†	----	----	----	----
H036	----	----	----	----	C360G†	C390G†
H065	C310H†	C320H†	----	C340H†	C360H†	----
H090	----	C3290†	----	C3490†	C3690†	----
H115	C310J†	C320J†	----	C340J†	----	----
H175	C310K†	C320K†	----	----	----	----
J065	----	----	----	----	C360H†	C390H†
J090	----	----	----	----	C3690†	----
J115	C310J†	C320J†	----	C340J†	C360J†	----
J175	C310K†	C320K†	----	C340K†	----	----
J220	C3120H	C3220H	----	----	----	----
J335	C3123†	C3223†	----	----	----	----
J345	C3145†	C3245†	----	----	----	----
K115	----	----	----	----	C360J†	C390J†
K175	C310K†	C320K†	----	C340K†	C360K†	----
K335	C3123†	C3223†	C3323†	----	----	----
K345	C3145†	C3245†	C3345†	----	----	----
K620	C3162†	C3262†	----	----	----	----
K800	C3180†	C3280†	----	----	----	----

† Add third letter of Type Designation to complete the part number; i.e., for Type CDQ, add Q to basic number of stator.

Table 4-7. Connecting Rod (Ref. No. 38) Part Number

MODEL	TYPE DESIGNATION	
	CDQ, CDR, CDB, CDF	CSQ, CSR, CSB, CSF, SSQ, SSR, SSB, SSF
E008, E012, E018E, E022, E033E E036	PE0251 PE0252	PE0256 PE0257
F012, F022, F033E, F036, F050, F054E, F075E F065	PF0251 PF0252	PF0256 PF0257
G022, G036, G050, G054E, G065, G075E, G090, G098E G115	PG0251 PG0252	PG0256 PG0257
H036, H065, H090, H115 H175	PH0251 PH0252	PH0256 PH0257
J065, J090, J115, J175, J345, J220 J335	PJ0251 PJ0252	PJ0256 PJ0257
K115, K175, K335, K345, K620 K800	PK0251 PK0252	PK0256 PK0257

Table 4-8. Discharge Flange (Ref. No. 37) for Type Designations Beginning with CD

MODEL	STAGES			
	1, 2, AND 3	4	6	9
E008	BE0121	BE0122	BE0122	----
E012, E018E	BE0121	BE0122	BE0122	----
E022, E033E	BF0121	BF0121	----	----
E036	BG0121	----	----	----
F012	----	----	BF0120	BF0120
F022, F033E	BF0121	BF0122	BF0122	----
F036, F054E	BG0121	BG0121	----	----
F050, F075E	BG0121	BG0121	----	----
F065	BH0121	----	----	----
G022	----	----	BG0120	BG0120
G036, G054E	BG0121	BG0122	BG0122	----
G050, G075E	BG0121	BG0122	BG0122	----
G065, G098E	BH0121	BH0121	----	----
G090	BH0121	BH0121	----	----
G115	BJ0121	----	----	----
H036	----	----	BH0120	BH0120
H065	BH0121	BH0122	BH0122	----
H090	BH0121	BH0122	BH0122	----
H115	BH0121	BH0121	----	----
H175	BK0121	----	----	----
J065	----	----	BJ0120	BJ0120
J090	----	----	BJ0120	----
J115	BH0121	BH0122	BH0122	----
J175	BK0121	BK0121	----	----
J335, J220	BK0121	----	----	----
K115	----	----	BJ0120	BJ0120
K175	BK0121	WK0121	WK0121	----
1K335	BK0121	----	----	----
2K335	WK0121	----	----	----
3K335	WK0121	----	----	----
1K345	BK0121	----	----	----
2K345	WK0121	----	----	----
3K345	WK0121	----	----	----
1K620	WK0121	----	----	----
2K620	WK0121	----	----	----
1K800	WK0122	----	----	----
2K800	WK0122	----	----	----

Table 4-9. Discharge Flange (Ref. No. 37) for Type Designations Beginning with CS or SS

MODEL	STAGES			
	1, 2, AND 3	4	6	9
E008, E012, E018E	6E0126	BE0127	BE0127	----
E022, E033E	BF0126	BF0126	----	----
E036, E050	BG0126	----	----	----
F012	----	----	BF0125	BF0125
F022, F033E	BF0126	BF0127	BF0127	----
F036, F050, F054E	BG0126	BG0126	----	----
F065, F090	BH0126	----	----	----
G022	----	----	BG0125	BG0125
G036, G050, G054E	BG0126	BG0127	BG0127	----
G065, G090, G098E	BH0126	BH0126	----	----
G115	BJ0126	----	----	----
H036	----	----	BH0125	BH0125
H065, H090	BH0126	BH0127	BH0127	----
H115	BH0126	BH0126	----	----
H175	BK0126	----	----	----
J065, J090	----	----	BJ0125	BJ0125
J115	BH0126	BH0127	BH0127	----
J175	BK0126	BK0126	----	----
J335, J345, J220	BK0126	----	----	----
K115	----	----	BJ0125	BJ0125
K175	BK0126	WK0126	WK0126	----
1k335, K345	BK0126	----	----	----
2K335, K345	WK0126	----	----	----
3K335, K345	WK0126	----	----	----
1K620	BK0126	----	----	----
2K620	WK0126	----	----	----
1K800	WK0127	----	----	----
2K800	WK0127	----	----	----

Table 4-10. Rotor (Ref. No. 40) for Type Designations Beginning with CD

MODEL	STAGES					
	1	2	3	4	6	9
E008	C71E81	C72E81	----	C74E81	C76E81	----
E012	C71EE1	C72EE1	----	C74EE1	C76EE1	----
E018E	E71E181	E72E181	----	----	----	----
E022	C71EF1	C72EF1	----	C74EF1	----	----
E033E	E71E331	E72E331	----	----	----	----
E036	C71EG1	C72EG1	----	----	----	----
E050	C71E51	C72E51	----	----	----	----
F012	----	----	----	----	C76FE1	C79FE1
F022	C71FF1	C72FF1	----	C74FF1	C76FF1	----
F033E	E71F331	E72F331	----	----	----	----
F036	C71FG1	C72FG1	----	C74FG1	----	----
F050	C71F51	C72F51	----	C74F51	----	----
F054E	E71F541	E72F541	----	----	----	----
F065	C71FH1	C72FH1	----	----	----	----
F075E	E71F751	E72F751	----	----	----	----
F090	C71F91	C72F91	----	----	----	----
G022	----	----	----	----	C76GF1	C79GF1
G036	C71GG1	C72GG1	----	C74GG1	C76GG1	----
G050	----	C72G51	----	C74G51	C76G51	----
G054E	E71G541	E72G541	----	----	----	----
G065	C71GH1	C72GH1	----	C74GH1	----	----
G075E	E71G751	E72G751	----	----	----	----
G090	C71G91	C72G91	----	C74G91	----	----
G098E	E71G981	E72G981	----	----	----	----
G115	C71GJ1	C72GJ1	----	----	----	----
H036	----	----	----	----	C76HG1	C79HG1
H065	C71HH1	C72HH1	----	C74HH1	C76HH1	----
H090	----	C72H91	----	C74H91	C76H91	----
H115	C71HJ1	C72HJ1	----	C74HJ1	----	----
H175	C71HK1	C72HK1	----	----	----	----
J065	----	----	----	----	C76JH1	C79JH1
J090	----	----	----	----	C76J91	----
J115	C71JJ1	C72JJ1	----	C74JJ1	C76JJ1	----
J175	C71JK1	C72JK1	----	C74JK1	----	----
J220	C71J21	C72J21	----	----	----	----
J335	C71J31	C72J31	C73J31	----	----	----
J345	C71J41	C72J41	----	----	----	----
K115	----	----	----	----	C76KJ1	C76KJ1
K175	C71KK1	C72KK1	----	C74KK1	C76KK1	----
K335	C71231	C72231	C73231	----	----	----
K345	C71341	C72341	C73341	----	----	----
K620	C71621	C72621	----	----	----	----
K800	C71801	C72801	----	----	----	----

Table 4-11. Rotor (Ref. No. 40) for Type Designations Beginning with CS or SS

MODEL	STAGES					
	1	2	3	4	6	9
E008	C81E81	C82E81	----	C84E81	C86E81	----
E012	C81EE1	C82EE1	----	C84EE1	C86EE1	----
E018E	E81E181	E82E181	----	----	----	----
E022	C81EF1	C82EF1	----	C84EF1	----	----
E033E	E81E331	E82E331	----	----	----	----
E036	C81EG1	C82EG1	----	----	----	----
E050	C81E51	C82E51	----	----	----	----
F012	----	----	----	----	C86FE1	C89FE1
F022	C81FF1	C82FF1	----	C84FF1	C86FF1	----
F033E	E81F331	E82F331	----	----	----	----
F036	C81FG1	C82FG1	----	C84FG1	----	----
F050	C81F51	C82F51	----	C84F51	----	----
F054E	E81F541	E82F541	----	----	----	----
F065	C81FH1	C82FH1	----	----	----	----
F075E	E81F751	E82F751	----	----	----	----
F090	C81F91	C82F91	----	----	----	----
G022	----	----	----	----	C86GF1	C89GF1
G036	C81GG1	C82GG1	----	C84GG1	C86GG1	----
G050	----	C82G51	----	C84G51	C86G51	----
G054E	E81G541	E82G541	----	----	----	----
G065	C81GH1	C82GH1	----	C84GH1	----	----
G075E	E81G751	E82G751	----	----	----	----
G090	C81G91	C82G91	----	C84G91	----	----
G098E	E81G981	E82G981	----	----	----	----
G115	C81GJ1	C82GJ1	----	----	----	----
H036	----	----	----	----	C86HG1	C89HG1
H065	C81HH1	C82HH1	----	C84HH1	C86HH1	----
H090	----	C82H91	----	C84H91	C86H91	----
H115	C81HJ1	C82HJ1	----	C84HJ1	----	----
H175	C81HK1	C82HK1	----	----	----	----
J065	----	----	----	----	C86JH1	C89JH1
J090	----	----	----	----	C86J91	----
J115	C81JJ1	C82JJ1	----	C84JJ1	C86JJ1	----
J175	C81JK1	C82JK1	----	C84JK1	----	----
J220	C81J21	C82J21	----	----	----	----
J335	C81J31	C82J31	C83J31	----	----	----
J345	C81J41	C82J41	----	----	----	----
K115	----	----	----	----	C84KJ1	C86KJ1
K175	C81KK1	C82KK1	----	C84KK1	C86KK1	----
K335	C81231	C82231	C83231	----	----	----
K345	C81341	C82341	C83341	----	----	----
K620	C81621	C82621	----	----	----	----
K800	C81801	C82801	----	----	----	----

Table 4-12. Head Ring (Ref. No. 42) Part Number

MODEL	TYPE DESIGNATION	
	CDQ, CDR, CDB, CDF	CSQ, CSR, CSB, CSF, SSQ, SSR, SSB, SSF
E008, E012, E018E, E022, E033E, E036, E050,	PE033D PE034D	PE033S PE034S
F012, F022, F036, F050 F033E, F054E, F065, F075E, F090	PF033D PF034D	PF033S PF034S
G022, G036, G050, G054E, G065, G075E, G090, G098E, G115	PG033D PG034D	PG033S PG034S
H036, H065, H090, H115, H175	PH033D PH034D	PH033S PH034S
J065, J090, J115, J175, J335, J345, J220	PJ033D PJ034D	PJ033S PJ034S
K115, K175, K335, K345, K620, K800	PK033D	PK033S

SEE PG. 23 FOR EXPLODED VIEW OF PUMP

Table 4-13. Shaft Sleeve Arrangement

REF. NO:	43 SHAFT SLEEVE KIT*			22A PACKING	23A LANTERN RING HALF	21A PACKING GLAND HALF		29A SUCTION HOUSING	
	CDO, CSR CDR, SSQ CSQ, SSR	CDB CSB SSB	CDF CSF SSF	ALL MODELS	ALL MODELS	CD CS	SS	CD CS	SS
MODEL									
E008, E012, E018E	KE003Q	KE003B	KE003F	PF0423	PF0571	PE042D	PE042S	PE0024	PE0029
E022, E033E	KE003Q	KE003B	KE003F	PF0423	PF0571	PE042D	PE042S	PE0028	PE0030
E036, E050	KE003Q	KE003B	KE003F	PF0423	PF0571	PE042D	PE042S	PE0033	PE0034
F012, F022, F033E	KF003Q	KF003B	KF003F	PF1423	PF1571	PF042D	PF042S	PF0024	PF0029
F036, F050, F054E	KF003Q	KF003B	KF003F	PF1423	PF1571	PF042D	PF042S	PF0028	PF0030
F065, F090	KF003Q	KF003B	KF003F	PF1423	PF1571	PF042D	PF042S	PF0033	PF0034
G022, G036, G050, G054E, G075E	KG003Q	HG003B	KG003F	PH0423	PH0571	PG042D	PG042S	PG0024	PG0029
G065, G090, G098E	KG003Q	KG003B	KG003F	PH0423	PH0571	PG042D	PG042S	PG0028	PG0030
G115	KG003Q	KG003B	KG003F	PH0423	PH0571	PG042D	PG042S	PG0033	PG0034
H036, H065, H090, H115	KH003Q	KH003B	KH003F	PH1423	PH1571	PH042D	PH042S	PH0024	PH0029
H175	KH003Q	KH003B	KH003F	PH1423	PH1571	PH042D	PH042S	PH0033	PH0034
J065, J090, J115	KJ003Q	KJ003B	KJ003F	PJ1423	PJ1571	PJ042D	PJ042S	PJ0024	PJ0029
J175, J335	KJ003Q	KJ003B	KJ003F	PJ1423	PJ1571	PJ042D	PJ042S	PJ0028	PJ0030
J345	KJ003Q	KJ003B	KJ003F	PJ1423	PJ1571	PJ042D	PJ042S	PJ0033	PJ0034
K115, K175, K335 K345, K620	KK003Q	KK003B	KK003F	PK1423	PK1571	PK042D	PK042S	PK0024	PK0029
K800	KK003Q	KK003B	KK003F	PK1423	PK1571	PK042D	PK042S	PK0030	PK0031

*Kit includes Shaft Sleeve (Ref. No. 45), Set Screws (Ref. No. 46), and 2 O-Rings (Ref. No. 44).

Table 4.14. Shaft Sleeve Conversion Kit**

MODEL	CDQ CDR	CDF	CDB	CSQ, SSQ CSR, SSR	CSB SSB	CSF SSF
E	KE009Q	KE009F	KE009B	KE015Q	KE015B	KE015F
F	KF009Q	KF009F	KF009B	KF015Q	KF015B	KF015F
G	KG009Q	KG009F	KG009B	KG015Q	KG015B	KG015F
H	KH009Q	KH009F	KH009B	KH015Q	KH015B	KH015F
J	KJ009Q	KJ009F	KJ009B	KJ015Q	KJ015B	KJ015F

**Kit includes Shaft Sleeve Kit (Ref. No. 43), Packing (Ref. No. 22A), 2 Lantern Ring Halves (Ref. No. 23A), and 2 Packing Gland Halves (Ref. No. 21A).

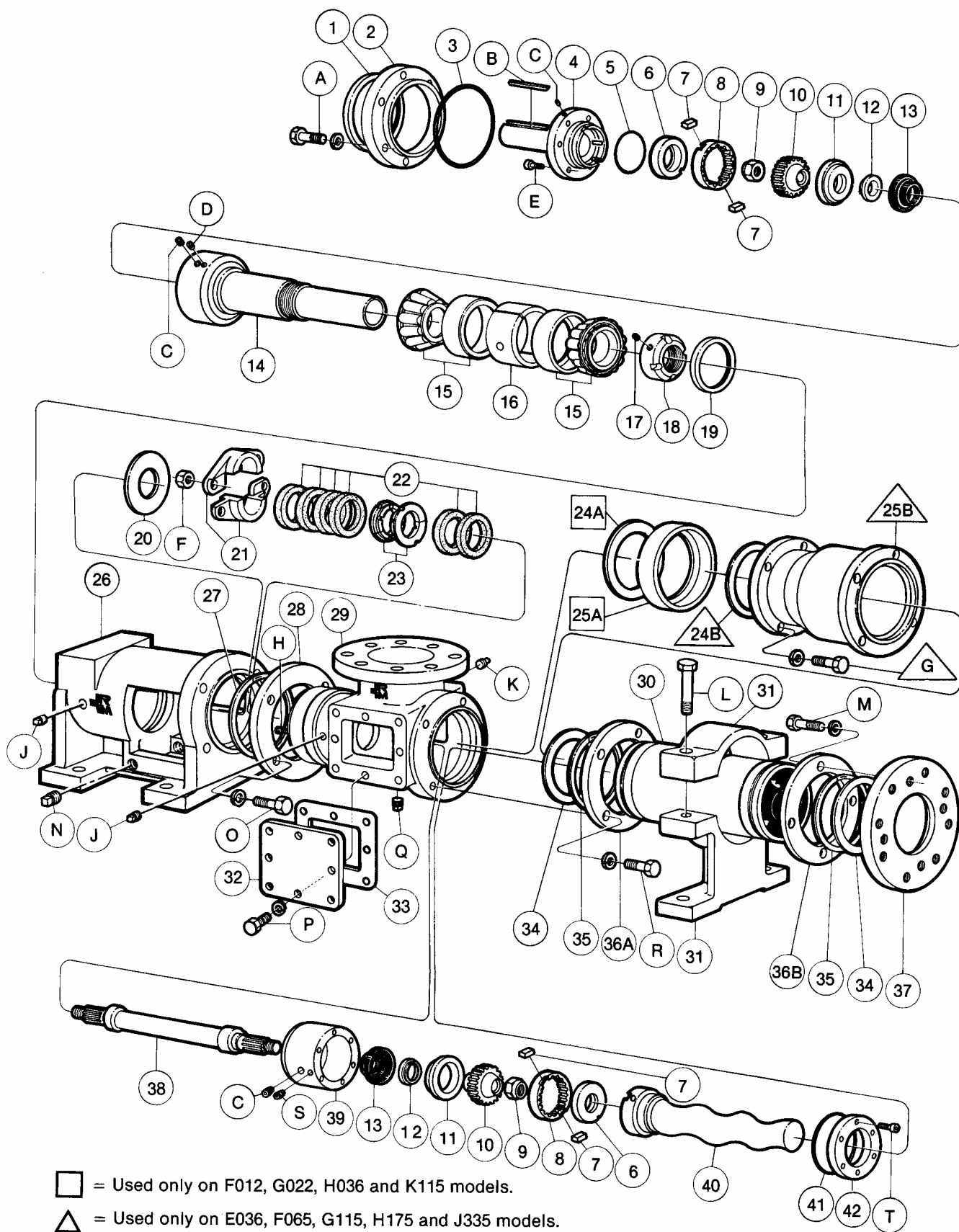

Figure 4-8. Pump Exploded View

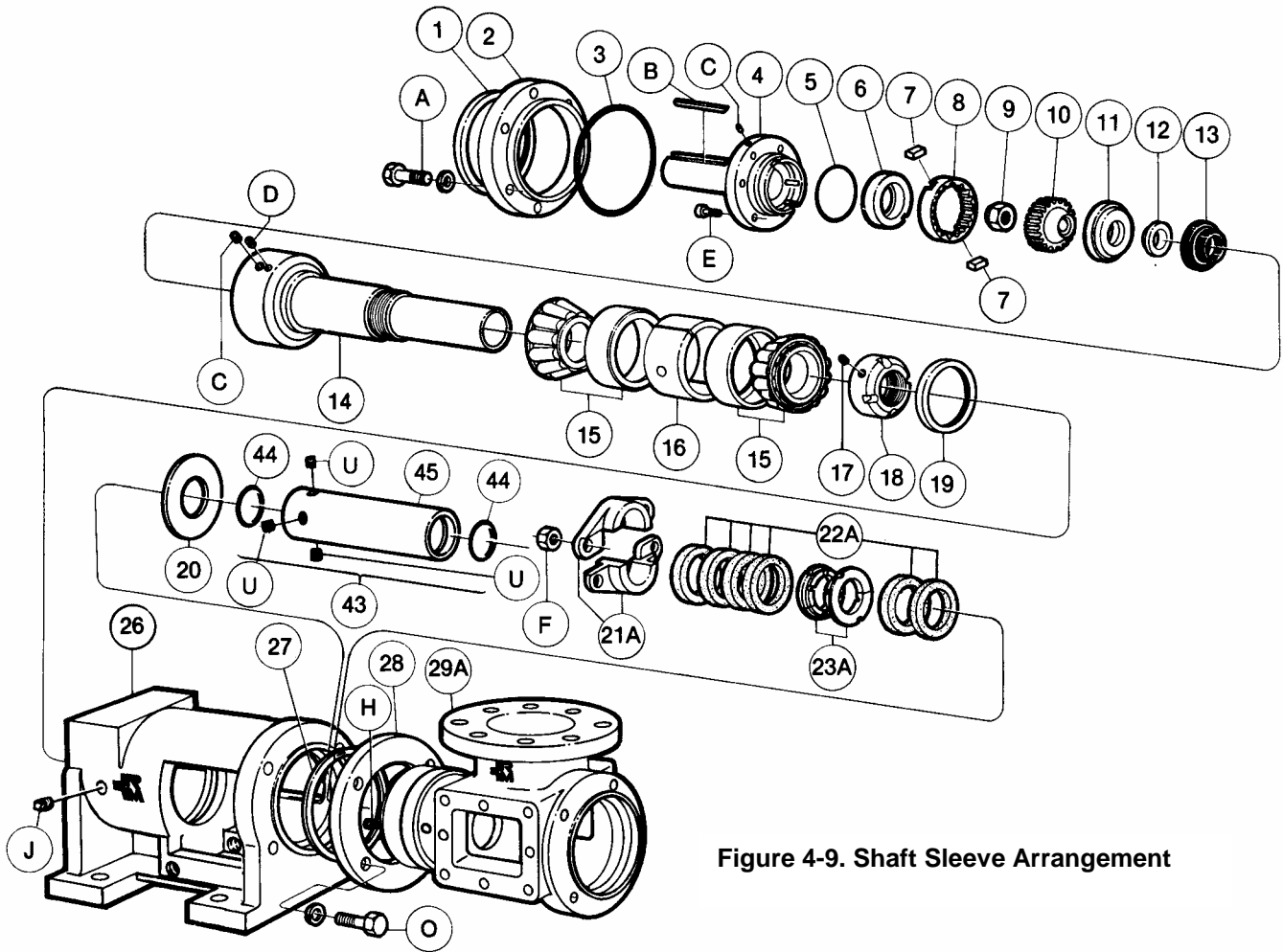

Figure 4-9. Shaft Sleeve Arrangement

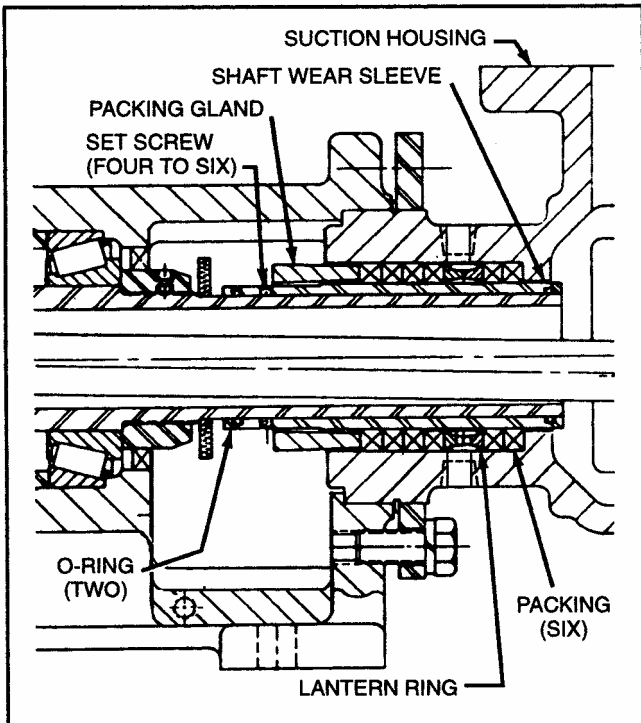

Figure 4-10. Pump with Shaft Wear Sleeve

4-46. SHAFT SLEEVE ARRANGEMENT

Some pumps have a sleeve installed on the drive shaft to receive any possible wear caused by the packing. See sleeve kit (fig. 4-9), and the cross section illustration (fig. 4-10).

4-47. Disassembly (see fig. 4-9). After separation of bearing housing (26) from suction housing (29A), and removal of packing gland and packings, remove sleeve as follows:

1. Loosen four to six set screws (U) in sleeve (45), and pull sleeve off shaft (14).
2. Remove two O-rings (44) from interior of sleeve.

4-48. Assembly. Assemble pump to the point where slinger ring (20) is installed on drive shaft (14), then install sleeve kit (43) as follows:

1. Lubricate two O-rings (44) and insert in grooves in interior of sleeve (45). Loosely install four to six set screws (46) in sleeve, but be sure they do not protrude into interior of sleeve.
2. Install sleeve unit (44, 45, U) over drive shaft (14) so that set screw end of sleeve is in toward slinger ring (20).
3. Adjust sleeve to be flush with end of drive shaft, and tighten the four to six set screws (U).

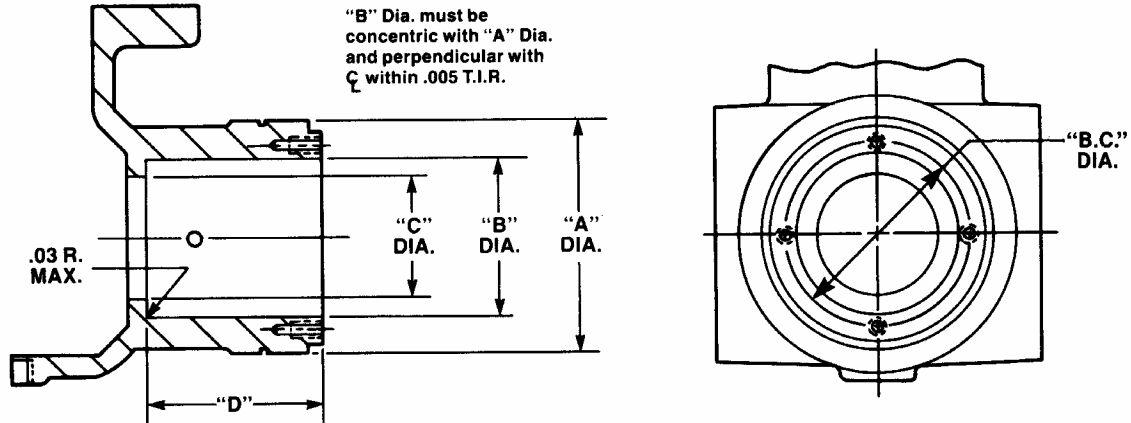

Figure 4-11. Stuffing Box.

Drive End Size	Dimensions with shaft sleeve (inches)					
	A ^{+ .000} / _{- .003}	B ^{+ .005} / _{- .00} (1)	C ^{± .03} (1)	D ^{+ .05} / _{- .00}	B.C.	Shaft O.D.
E	5.500	3.750	2.81	4.19	4.37	2.750
F	6.589	4.250	3.31	4.44	5.00	3.250
G	7.498	5.000	3.81	4.94	5.87	3.750
H	8.589	5.500	4.31	4.94	6.50	4.250
J	9.500	6.750	5.31	5.75	7.75	5.250
K	11.000	7.750	6.06	6.81	9.00	6.000

(1) If you already have a suction housing machined for use without a shaft sleeve, these dimensions must be reworked in order to install a shaft sleeve in your pump.

Drive End Size	Dimensions without shaft sleeve (inches)					
	A ^{+ .000} / _{- .003}	B ^{+ .005} / _{- .00} (1)	C ^{± .03} (1)	D ^{+ .05} / _{- .00}	B.C.	Shaft O.D.
E	5.500	3.250	2.31	4.19	4.37	2.250
F	6.589	3.750	2.81	4.44	5.00	2.750
G	7.498	4.500	3.31	4.94	5.87	3.250
H	8.589	5.000	3.86	4.94	6.50	3.750
J	9.500	6.000	4.56	5.75	7.75	4.500
K	11.000	7.000	5.31	6.81	9.00	5.250

4-49. FIBER DEFLECTOR OPTION

4-50. OPERATION

The Moyno Fiber Deflector is designed to prevent an accumulation of rags and stringy material around the connecting rod and rotor head area of your Moyno 2000 pump. The Fiber Deflector eliminates the potential for equipment damage and downtime due to blockage.

The Fiber Deflector operates in a similar way to an end face-type mechanical seal. The stationary lip of the deflector cover rides against a polished disk rotating with the gear joint shell. The deflector cover does not seal fluid from entering the drive shaft; it only shields debris from wrapping around the connecting rod.

4-51. DISASSEMBLY/ASSEMBLY

A Moyno 2000 pump purchased from the factory and equipped with a fiber deflector needs no adjustments. When service becomes necessary, however, and you must disassemble the pump, follow these steps for dismantling the fiber deflector:

1. Remove the inspection plate and gasket.
2. Pull back the end of the deflector cover exposing the two machine screws holding the face ring to the support ring.

Note: The two machine screws will be facing one of the two inspection plates.

3. Loosen the machine screws and slide the face ring and deflector cover away from the gear joint shell.
4. Disassemble the rest of the pump as described in this manual.
5. After you completely reassemble the pump, slide the face ring and deflector cover toward the gear joint shell until the rubber lip of the deflector cover contacts the disk on the gear joint.

6. Tighten the two machine screws and fold the end of the deflector cover over the machine screws.

7. Reassemble the inspection plate gasket and inspection plate.

4-52. PARTS LIST

Drive End	Size Deflector Cover
E	PE0595
F	PF0595
G	PG0595
H	PH0595
J	PJ0595
K	PK0595

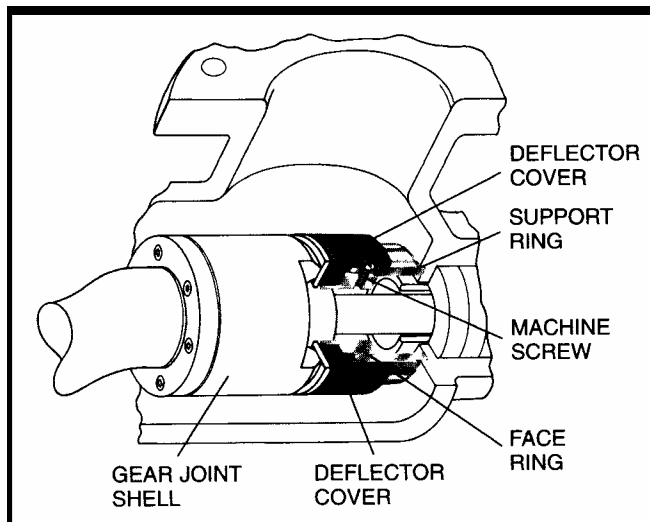

Figure 4-12. Fiber Deflector

4-53. FLUSH GLAND OPTION

4-54. GENERAL

The flushable packing gland allows packing leakage to be conveniently flushed away from the pump, providing a clean, safe environment and preventing potential damage to seals and bearings. The gland is used in many waste treatment and paper industry applications, where process fluid leakage past compression packing and settling around the pump unit cannot be tolerated.

Compression packing is designed to permit a controlled leakage of process or flush fluid, not to stop it completely. Leakage is necessary to reduce shaft friction and dissipate heat. The flushable gland has inlet and outlet connections that can be plumbed to a flush medium supply and flush medium drain. As packing leakage enters the gland it is flushed away to the drain.

The flushable packing gland is available for Moyno 2000 pumps, both in the "G1" flanged models and "G2" open throat models. It can be installed on pumps with or without shaft sleeves.

4-55. INSTALLATION

When retrofitting a pump that already has a standard gland, follow these steps:

1. Remove the original packing gland halves.
2. Remove the packing and lantern rings.
3. Remove the gland studs.
4. Clean the surfaces of the drive shaft and stuffing box.
5. Install a new set of packing rings. See the following table for the proper number of packing rings for your pump size.

NOTE: Standard packing set includes 6 rings of packing. If lantern ring is not used, 2 sets of standard packing are needed to meet the packing quantity guidelines.

6. Wipe a small amount of grease in the groove of the flush gland halves.

7. Work the split lip seal into the groove of one of the gland halves.

8. Position the split such that it is away from the gland, allowing the assembly to be placed around the drive shaft. The lip of the seal should face away from the pump's bearings.

9. Work the lip seal into the groove of the remaining gland half.

PACKING QUANTITY GUIDELINES

Drive End Size	No. of Packing Rings	
	Without Lantern Ring	With Lantern Ring
E	8	6
F	9	6
G	7	6
H	7	6
J	7	6
K	7	6

10. With the seal in position and the gland halves held together, install the two stainless steel cap screws.

11. Install the gland studs.

12. Slide the gland assembly onto the gland studs finger tight.

13. Thread the appropriate hex bushing (depending on flush gland inlet size) into the flush gland.

14. Thread the pressure regulator and pressure gauge assembly into the hex bushing.

Note: The pressure regulator will reduce inlet water to below 8 psig, protecting the flush gland lip seal. Failure to utilize the pressure regulator may result in premature pump failure.

4-56. OPERATION

A flushable packing gland can be operated in one of two ways:

- If the process fluid is relatively clean (non-abrasive) and cannot be diluted by water flushing, allow it to leak along the shaft, to provide both lubrication and heat dissipation. The leakage will spill into the gland and be flushed to the drain. No lantern rings are required, only the number of packing rings listed in the above table. If the gland is operated this way, pipe plugs should be installed in the 1/8-inch NPT holes in the stuffing box.

- For applications involving abrasive fluids that can be diluted somewhat with flush water, it is recommended that you equip the stuffing box with lantern rings and install a water flush line in the 1/8-inch NPT hole. Excess water spilling into the gland can be plumbed to the drain. Install a pipe plug, instead of a water supply line, in the flush gland inlet.

Having determined the best alternative for your application, install all hardware, leaving the flush gland drain unconnected for now. Packing gland nuts should be evenly adjusted so they are a little more than finger tight. Overtightening the packing may result in premature packing failure and possible damage to the drive shaft.

1. Start the pump and water flush the stuffing box if applicable (do not start the water flush in the gland at this point).

2. Adjust the gland nuts until you obtain a leakage rate of 1-2 drops per second. The flush gland drain must be disconnected to adjust the rate.

3. Allow the pump to run, checking the leakage rate every 15 minutes. If leakage becomes excessive, tighten the gland nuts until the leakage amount is acceptable.

CAUTION: Do not tighten the gland nuts to the point of zero leakage from the stuffing box.

4. Once the packing has seated and the leakage rate has stabilized, the flush gland drain can be connected and flush water can be run into the top side of the gland. Do not place a throttling valve on the drain side of the flush gland. Do not produce back pressure by any other way. Back pressure is not necessary and is detrimental to the function of the gland.

5. Adjust flush water flow rate to an acceptable rate.

4-57. STANDARD HARDWARE

Ref. No.	Description	Qty.	Drive End					
			E	F	G	H	J	K
A	Hex Head Screw	2	¼-20 x 2" Lg	¼-20 x 2" Lg	5/16-18 x 2¼" Lg	3/8-16 x 2 ¾" Lg	3/8-16 x 2¼" Lg	½-13 x 3¼" Lg

Note: All screws are 18-8 stainless steel.

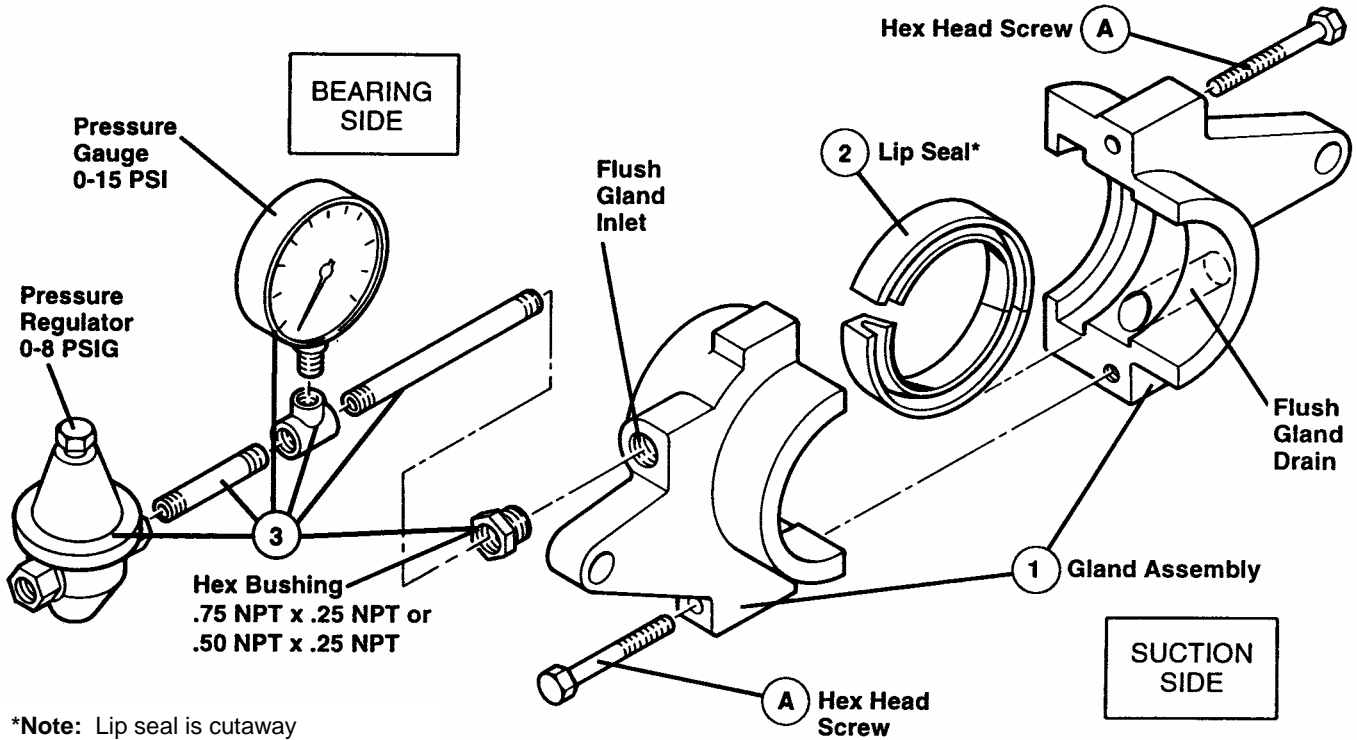

Figure 4-13. Flush Gland

4-58. PARTS LIST

Drive End Size	With Shaft Sleeve			Without Shaft Sleeve		
	Gland Assembly (Ref. No. 1)	Lip Seal (Ref. No.2)	Flush Assembly (Ref. No.3)	Gland Assembly (Ref. No. 1)	Lip Seal (Ref. No.2)	Flush Assembly (Ref. No.3)
E	PE044D	PF0591		PE043D	PE0591	
F	PF044D	PG0591		PF043D	PF0591	
G	PG044D	PH0591		PG043D	PG0591	
H	PH044D	PH0592	PFA001	PH043D	PH0591	PFA001
J	PJ044D	PK0591	(all sizes)	PJ043D	PJ0591	(all sizes)
K	PK044D	PK0592		PK043D	PK0591	

4-59. TROUBLESHOOTING CHART

PUMP PROBLEMS

Pump does not rotate.															
Pump does not discharge.															
Discharge output low.															
Discharge output fluctuates.															
Pump drive overloaded.															
Pump noisy.															
Shaft seal leaks.															
Stator wears too fast.															
Rotor wears too fast.															
PROBABLE CAUSE AND REMEDY															
Incorrect power supply; drive not properly wired. <i>Check motor nameplate data; test voltage, phase, & frequency.</i>												•	•	•	
Foreign matter in pump. <i>Remove foreign matter.</i>												•	•	•	•
If pump or stator is new, too much static friction. <i>Fill with liquid, and hand turn.</i>															•
Stator swells due to chemical attack. <i>Change stator material.</i>											•				•
Stator swells due to high liquid temp. <i>Reduce liquid temp. or use an undersized rotor.</i>											•				•
Blockage due to solids in liquid. <i>Decrease solids-to-liquid ratio.</i>											•	•	•	•	•
Liquid settles and hardens after pump shut down. <i>Clean and rinse pump after each use.</i>											•	•	•	•	•
Suction pipe not submerged. <i>Reposition suction pipe.</i>												•	•	•	•
Air in suction pipe. <i>Tighten connections to stop leaks.</i>												•	•	•	•
Pump speed too low. <i>Increase drive speed.</i>														•	•
Suction lift too high (cavitation). <i>Reduce suction losses; move pump to lower elevation; increase pipe size.</i>												•	•	•	•
Pump running dry; no prime. <i>Fill pump with liquid; relocate suction piping.</i>												•	•	•	•
Stator worn excessively. <i>Replace stator & inspect rotor.</i>													•	•	•
Rotor worn excessively. <i>Replace rotor.</i>													•	•	•
Wrong direction of rotation. <i>Reverse drive motor polarity.</i>													•		•
Discharge pressure too high. <i>Open discharge valve; reduce discharge pipe length; remove obstruction, increase pipe size.</i>													•	•	•
Suction pipe leaks. <i>Tighten pipe connections.</i>													•	•	•
Shaft packing leaks. <i>Tighten packing gland; replace packing; lubricate packing.</i>														•	•
Stator material brittle. <i>Replace stator.</i>													•		•
Pump speed too high. <i>Reduce drive speed.</i>													•	•	•
Liquid viscosity or specific gravity too high. <i>Measure and compare with specification.</i>														•	•
Packing too tight. <i>Loosen gland nuts, & lubricate packing.</i>														•	•
Bent drive shaft. <i>Replace drive shaft.</i>													•	•	
Drive and pump misaligned. <i>Re-align drive and pump.</i>														•	•
Flexible drive coupling worn. <i>Repair or replace coupling.</i>														•	
Drive shaft bearings worn. <i>Replace bearings.</i>													•	•	
Incorrect packing. <i>Change packing material.</i>													•		
Packing too loose. <i>Tighten gland nuts, & lubricate.</i>													•		
Incorrect parts. <i>If pump has been rebuilt, check to verify original Moyno parts used.</i>														•	•

NOTE: If further troubleshooting procedural information is needed, please contact your authorized Moyno Pump distributor.