

SPECIFICATION DATA  
**MOYNO® 500 PUMPS**  
300 SERIES MOTORIZED  
331, 332, 333, 344, 356 AND 367 MODELS

331, 332, 333, 344 MODELS

**DIMENSIONS**

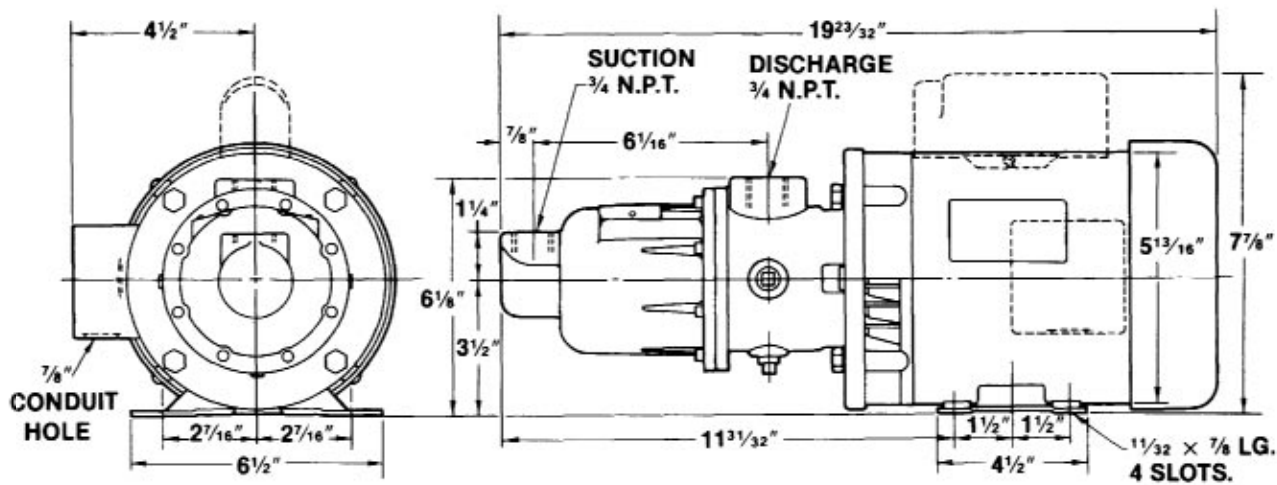

**MATERIALS OF CONSTRUCTION**

COMPONENT	MODELS			
	33159, 33259 33359, 34459	33160, 33260 33360, 34460	33152, 33252 33352, 34452	33150, 33250 33350, 34450
Housing	Cast iron	Cast iron	316SS	316SS
Rotor	416 SS/CP	416 SS/CP	316 SS/CP	316 SS/CP
Stator	NBR (Nitrile)	NBR (Nitrile)	NBR (Nitrile)	NBR (Nitrile)
Motor Data	1/2 HP, 1 PH 115/230 VAC 60 HZ TEFC	1/2 HP, 3 PH 230/440 VAC 60 HZ TEFC	1/2 HP, 1 PH 115/230 VAC 60 HZ TEFC	1/2 HP, 3 PH 230/440 VAC 60 HZ TEFC
Weight (lbs)	41	41	41	41

CP = Chrome plated

## PERFORMANCE (Water at 70°F)

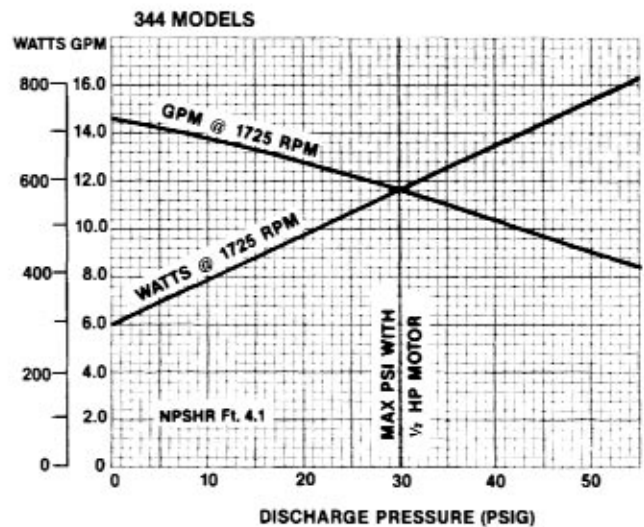
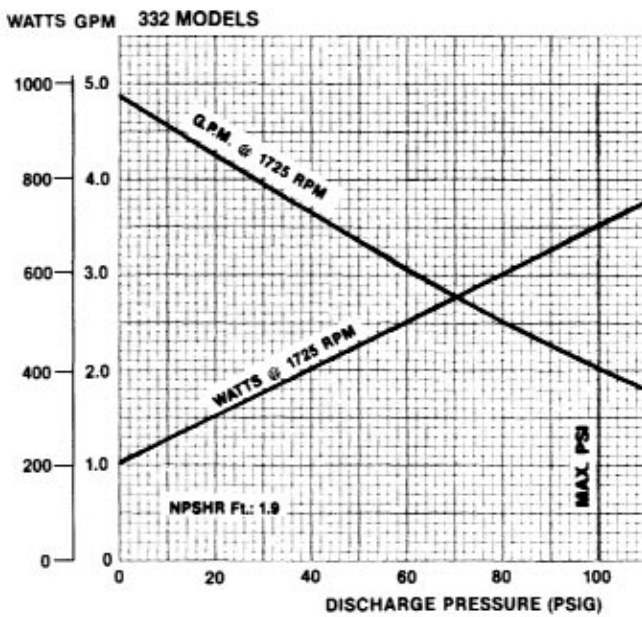
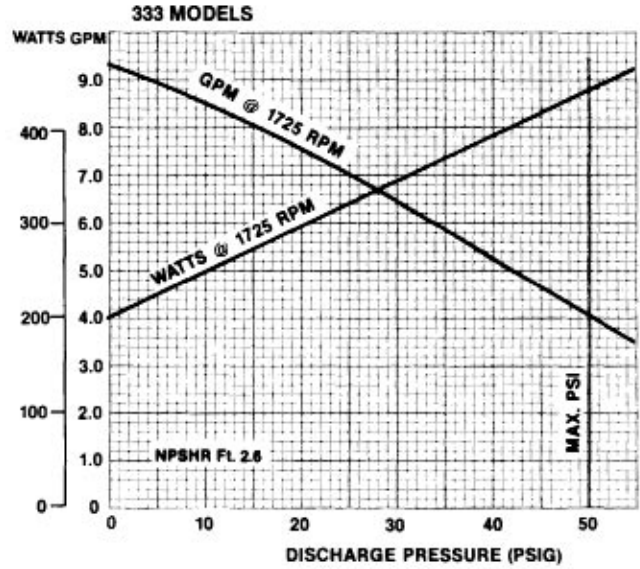
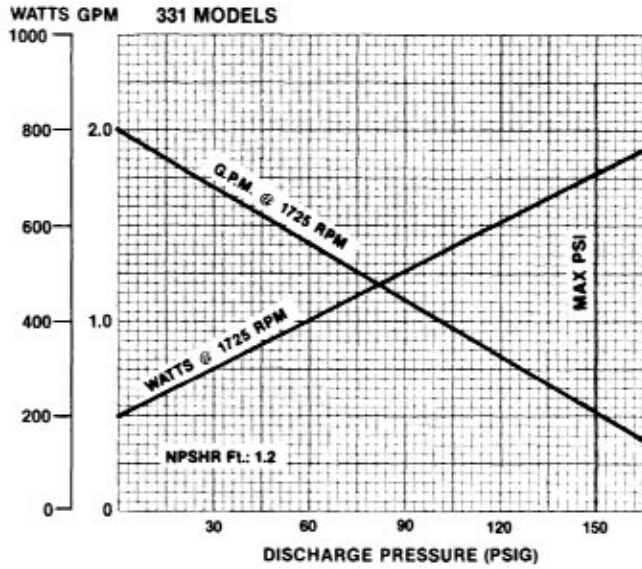

NOTE: With the standard 1/2 HP motor, maximum fluid viscosity is 100 CP (500 SSU).

## 356 AND 367 MODELS DIMENSIONS

### Model 35651

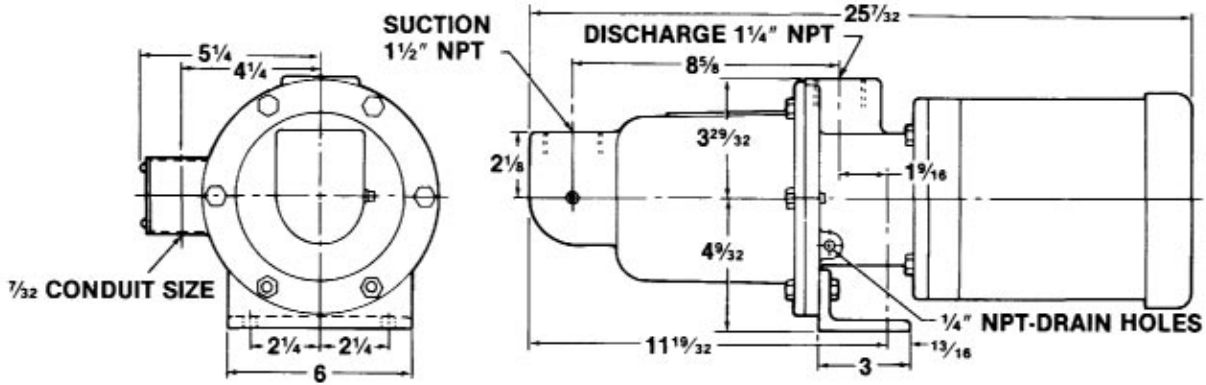

### Model 36751

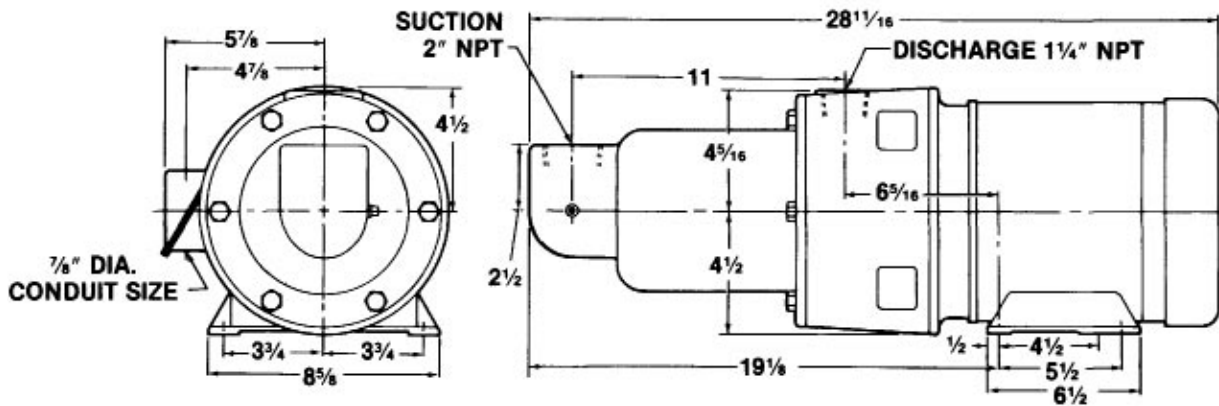

All dimensions are in inches.  
Specifications subject to change without notice.

## MATERIALS OF CONSTRUCTION

COMPONENT	MODELS					
	35651	36751	35650	35652	36750	36752
Housing	Cast iron	Cast iron	316 SS	316 SS	316 SS	316 SS
Rotor	416 SS/CP	416 SS/CP	316 SS/CP	316 SS/CP	316 SS/CP	316 SS/CP
Stator	NBR (Nitrile)	NBR (Nitrile)	NBR (Nitrile)	NBR (Nitrile)	NBR (Nitrile)	NBR (Nitrile)
Motor Data	1-1/2 HP, 3 PH 208/230/440 VAC 60 HZ TEFC	2 HP, 3 PH 230/440 VAC 60 HZ TEFC	1-1/2 HP, 3 PH 230/460 VAC 60 HZ TEFC	1-1/2 HP, 1 PH 115/230 VAC 60 HZ TEFC	2HP, 3 PH 230/460 VAC 60 HZ TEFC	2 HP, 1 PH 115/230 VAC 60 HZ TEFC
Weight (lbs)	68	115	68	68	115	115

CP = Chrome plated

# PERFORMANCE (Water at 70°F)

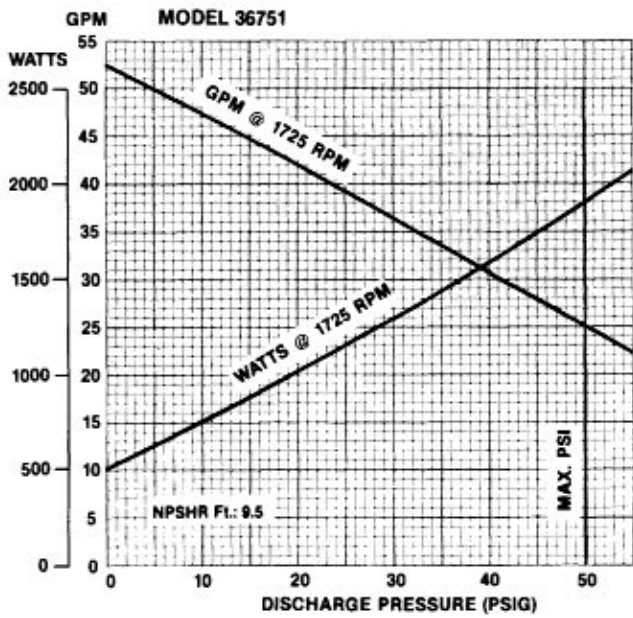
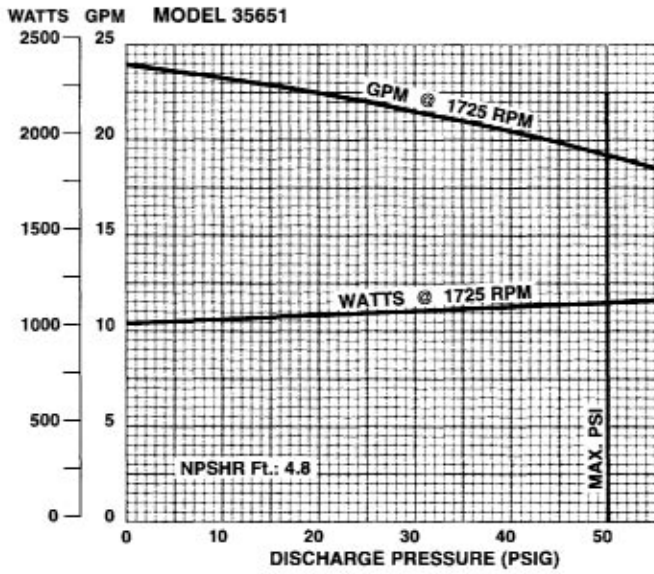

**NOTE:** With the standard  
1 1/2 HP (Model 35651)  
2 HP (Model 36751)  
motor, maximum fluid  
viscosity is 100 CP  
(500 SSU).