

SERVICE MANUAL MOYNO® 500 PUMPS

200 SERIES

20302, 20402, 20501, 20502, 22001, 22002, 23201, AND 23203 MODELS

DESIGN FEATURES

Housing: Stainless steel or aluminum
 Pump Rotor: Phenolic & AISI 316 stainless steel
 Pump Stator: NBR (Nitrile)
 Shaft: AISI 316 stainless steel
 Bearings: Prelubricated, fully sealed ball bearings
 Seal: Mechanical (carbon/ceramic)



Note: Alternate elastomers available. Refer to Repair/Conversion kit numbers, page 3.

INSTALLATION

Mounting Position. Pump may be mounted in any position. When mounting vertically, it is necessary to keep bearings above seals to prevent possible seal leakage into bearings.

Pre-Wetting. Prior to connecting pump, wet pump elements and mechanical seal by adding fluid to be pumped into suction and discharge ports. Turn shaft over several times in a clockwise direction to work fluid into elements.

Piping. Piping to pump should be self-supporting to avoid excessive strain on pump housings; 3/8" NPT pipe used on 203, 204, 205 and 220 Models, and 1/2" NPT pipe used on 232 Models. Use pipe "dope" or tape to facilitate disassembly and to provide seal.

Drive. On belt driven units, adjust belt tension to point of non-slip. Do not overtighten. On direct drive units, coupling components should be aligned and spaced at least 1/16" apart.

Pump rotation must be clockwise when facing shaft to prevent rotor unscrewing from shaft. Check direction of rotation before startup.

Maximum speed is 1750 rpm.

OPERATION

Self-Priming. With wetted pumping elements, the pump is capable of 25 feet of suction lift when operating at 1750 rpm with pipe size equal to port size. Be sure suction lines are air tight or pump will not self-prime.

Note: Self-priming capabilities will vary depending on fluid viscosity.

DO NOT RUN DRY. Unit depends on liquid pumped for lubrication. For proper lubrication, flow rate should be at least 10% of rated capacity at a given rpm.

Pressure and Temperature Limits. Maximum discharge pressure is 40 psig. Unit is suitable for service at temperatures shown in Table 1.

Storage. Always drain pump for extended storage periods using pipe plug in pump body.

Table 1. Temperature Limits

Elastomer	Temperature Limits
*NBR	10°-160°F
*EPDM	10°-210°F
*FPM	10°-240°F

*NBR = Nitrile

EPDM = Ethylene-Propylene-Diene Terpolymer

FPM = Fluoroelastomer

TROUBLE SHOOTING

WARNING: Before making adjustments, disconnect power source and thoroughly bleed pressure from system. Failure to do so could result in electric shock or serious bodily harm. Replace belt or coupling guards before reconnecting power.

Failure To Pump.

1. Belt or coupling slip: Adjust belt tension or tighten set screw on coupling.
2. Stator torn; possibly excessive pressure: Replace stator. Check pressure at discharge port.
3. Wrong rotation: Rotation must be clockwise when facing shaft.
4. Threads in rotor or on shaft stripped: Replace part. Check for proper rotation.
5. Excessive suction lift or vacuum.

Pump Overloads.

1. Excessive discharge pressure: Check discharge pressure for 40 psig maximum or obstruction in discharge line.
2. Fluid viscosity too high: Limit fluid viscosity to 20,000 CP or 100,000 SSU.
3. Suction pressure should never be greater than discharge pressure.

Viscosity CP	Limit RPM
1-300	1750
300-1,000	1200
1,000-2,000	700
2,000-5,000	350
5,000-10,000	180
10,000-20,000	100

4. Insufficient motor HP: Check HP requirement.

Noisy Operation.

1. Starved suction: Check fluid level, size of piping, and obstructions in pipe.
2. Bearings worn: Replace parts.
3. Insufficient mounting: Mount securely. Reduce vibration induced noise by using a short section of hose on discharge piping.

Seal Leakage.

1. Leakage at startup: If leakage is slight, allow pump to run several hours to let faces run in.
2. Persistent seal leakage: Faces may be cracked from freezing or thermal shock. Replace seal.

Pump Will Not Prime.

1. Air leak on suction side: Check pipe connections.

PUMP DISASSEMBLY

WARNING: Before disassembling pump, disconnect power source and thoroughly bleed pressure from system. Failure to do so could result in electric shock or serious bodily harm.

1. Disconnect suction and discharge piping.
2. Remove screws (9) which secure suction housing (2) to pump body (1). Remove suction housing (2) and stator (3).
3. Rotor (4) is removed from shaft (5) by turning in a counterclockwise direction (R H thread).
4. If any parts of the mechanical seal (8) are worn or broken, the complete seal assembly should be replaced. Seal components are matched parts and are not interchangeable.

5. The bearings (6) and shaft (5) assembly can be removed from the pump body (1) after the snap ring (7) has been removed. To remove the assembly, tap the shaft at the threaded end using a block of wood to protect the threads. Pull slinger ring (11) from shaft. The bearings (6) may then be pressed off the shaft.

Note: When replacing bearings, always press on the inner race when assembling to shaft, and on the outer race when pressing bearings into the housings to prevent damage to the races.

PUMP ASSEMBLY

1. Press inboard bearing on shaft using inner race. Install slinger ring (11) on shaft. Press inboard bearing & shaft into pump body using outer race. Press outboard bearing on shaft and into pump body using both races. Secure with snap ring (7).
2. Install mechanical seal (8) using the following procedure:
 - a. Clean and oil sealing faces using clean light oil (not grease).
 - b. Oil the outer surface of the seal seat, and push the assembly into the bore in the pump body (1), seating it firmly and squarely.
 - c. After cleaning and oiling the shaft, slide the seal body along the shaft until it meets the seal seat.
 - d. Install seal spring and spring retainer on shaft.
3. Screw rotor (4) on shaft (5) in a clockwise direction (R H thread).
4. Secure stator (3) and suction housing (2) to pump body (1) with screws (9).
5. Connect suction and discharge piping and proceed as outlined in installation instructions.

WARNING: Replace belt or coupling guards before reconnecting power.

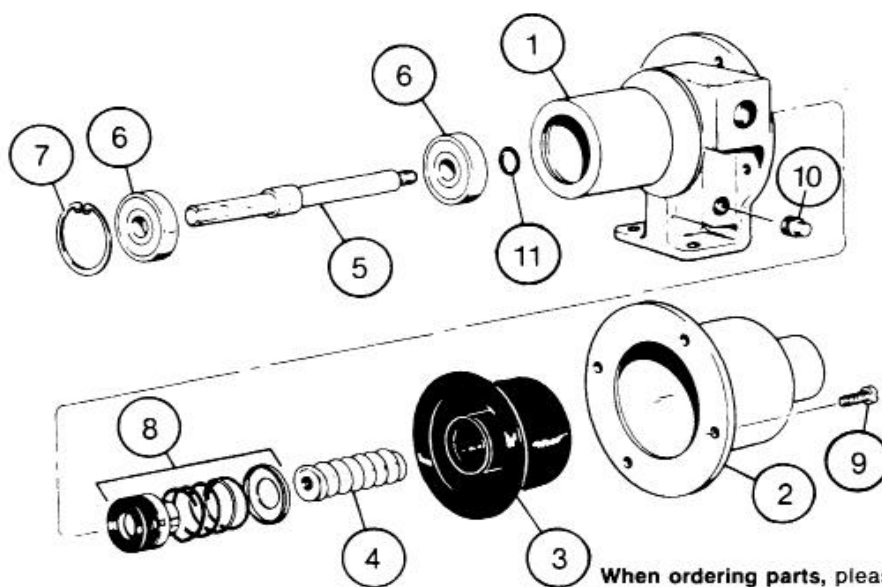

When ordering parts, please specify pump model number, pump serial number, part number, part description and quantity.

PARTS LIST

Item No.	Description	Pump Model Numbers							
		20302	20402	20501	20502	22001	22002	23201	23203
1	Pump Body	316 SS 330-3328-001	316 SS 330-3328-001	Aluminum 330-3215-001	316 SS 330-3328-001	Aluminum 330-3215-001	316 SS 330-3328-001	Aluminum 330-3215-000	316 SS 330-3328-000
2	Suction Housing	316 SS 330-3327-000	316 SS 330-3327-000	Aluminum 330-2234-000	316 SS 330-3327-000	Aluminum 330-2234-000	316 SS 330-3327-000	316 SS 330-2233-000	316 SS 330-3329-000
*3	Stator	NBR 330-7555-120	NBR 330-7556-120	NBR 330-6381-120		NBR 330-6382-120		NBR 330-6385-120	
*4	Rotor	316 SS 320-6975-000	316 SS 320-7923-000	Phenolic 320-6485-000	316 SS 320-6484-000	Phenolic 320-6488-000	316 SS 320-6487-000	416 SS 320-6498-000	316 SS 320-6499-000
5	Drive Shaft	320-6489-000							
6	Bearing (2 req.)	630-0502-021							
7	Snap Ring	320-4211-000							
*8	Mechanical Seal	320-4215-000							
9	Screws (4 req.)	320-4787-006		619-0850-061	320-4787-006	619-0850-061	320-4787-006	619-0850-061	320-4784-006
10	Pipe Plug	610-0420-010							
11	Slinger Ring	320-2833-008							

*Recommended spare parts.

REPAIR/CONVERSION KIT NUMBERS (Not available as kit for 203, 204 Models)

Item No.	Description	205 Models			220 Models		
		NBR	EPDM	FPM	NBR	EPDM	FPM
-	Kit No.	311-9061-000	311-9062-000	311-9063-000	311-9064-000	311-9065-000	311-9018-000
3	• Stator	330-6381-120	330-6381-320	330-6381-520	330-6382-120	330-6382-320	330-6382-520
8	• Seal	320-4215-000	320-6497-000	320-6037-000	320-4215-000	320-6497-000	320-6037-000
Item No.	Description	232 Models			NBR = Nitrile EPDM = Ethylene Proylene Diene Terpolymer FPM = Fluoroelastomer		
		NBR	EPDM	FPM			
-	Kit No.	311-9066-000	311-9067-000	311-9021-000			
3	• Stator	330-6385-120	330-6385-320	330-6385-520			
8	• Seal	320-4215-000	320-6497-000	320-6037-000			

