



Always the Right Solution™

Section:  
MOYNO® 500 PUMPS

Page: 1 of 6

Date: March 1, 1998

# SERVICE MANUAL

## MOYNO® 500 PUMPS

### 400 SERIES GRINDER PUMPS

#### 41502, 42202, 43302, AND 44402 MODELS

#### DESIGN FEATURES

Housing: Cast iron  
Pump Rotor: Chrome plated AISI 416 stainless steel  
Pump Stator: NBR (Nitrile)  
Shaft: AISI 416 stainless steel  
Bearings: Prelubricated, fully sealed ball bearings  
Seal: Mechanical (carbon/ceramic)  
Cutter Ring: Hardened steel  
Cutter Disc: Cast iron  
Cutter Tips: Carbide

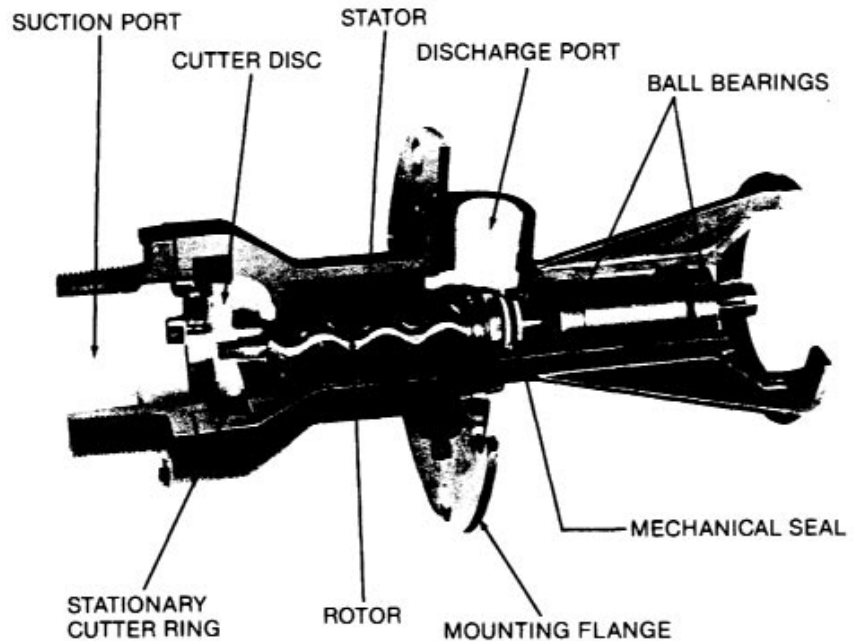

#### INSTALLATION

**Mounting Position.** Pump may be mounted in any position. When mounting vertically, it is necessary to keep bearings above seals to prevent possible seal leakage into bearings.

Pump is not self priming. Be sure pumping elements are located at or below water line.

**Piping.** Piping to pump should be self-supporting to avoid excessive strain on pump housings; 4" NPT male connection on suction port, 1-1/4" NPT female connection on discharge port. Be sure suction lines are airtight. A non-clogging type check valve should be used in discharge piping to prevent flow back through pump. Use pipe "dope" or tape to facilitate disassembly and to provide seal.

**Drive.** Any 56 frame, C-face, 1 HP, 1750 rpm, motor may be selected to meet code or application requirements. Motor is bolted directly to pump flange using hardware supplied with pump.

**CAUTION:** Use only the rectangular key (202) supplied with hardware kit to prevent damage to shafts.

Pump rotation must be clockwise when facing shaft to prevent rotor unscrewing from shaft. Check direction of rotation before startup.

Maximum speed is 1750 rpm and is the recommended speed for most effective grinding.

#### OPERATION

**Self-Priming.** Pump is not self-priming. Pumping elements should be located at or below water line. Be sure suction lines are airtight.

**DO NOT RUN DRY.** Unit depends on liquid pumped for lubrication. For proper lubrication, flow rate should be at least 10% of rated capacity.

**Pressure and Temperature Limits.** Maximum discharge pressure is 80 feet of water or 35 psig. Unit is suitable for service at 10° to 160°F.

**Storage.** Always drain pump for extended storage periods.

## TROUBLE SHOOTING

**WARNING:** Before making adjustments, disconnect power source and thoroughly bleed pressure from system. Failure to do so could result in electric shock or serious bodily harm.

### Failure To Pump.

1. Motor shaft turns; pump shaft will not: Check key, collar, and collar screw. Adjust if necessary.
2. Torn stator; possibly excessive pressure: Replace stator, check pressure at discharge port.
3. Wrong rotation: Rotation must be clockwise when facing shaft.
4. Threads in rotor or on shaft stripped: Replace part. Check for proper rotation.
5. Rotor pin sheared at rotor connection: Possibly excessive pressure. Replace parts, check pressure at discharge port.
6. Excessive suction lift or vacuum.

### Pump Overloads.

1. Excessive discharge pressure: Check discharge pressure for maximum rating given in Table 1. Check for obstruction in discharge pipe.
2. Fluid viscosity too high: Limit fluid viscosity to 100 CP or 500 SSU.
3. Insufficient motor HP: Check HP requirement.

### Will Not Start.

1. Low voltage: Check power supply and wiring.
2. Faulty motor: Replace or repair.
3. Grinder section jammed: Rotate drive shaft counterclockwise 1/4 turn to unjam cutters. If pump still will not start, check grinder section for jammed material and remove.

### Noisy Operation.

1. Starved suction: Check fluid level, size of piping, and obstructions in pipe.
2. Bearings worn: Replace parts.
3. Insufficient mounting: Mount securely. Reduce vibration induced noise by using a short section of hose on discharge piping.
4. Cutter disc contacts stationary cutter ring: Refer to grinder orientated problem section of guide.

### Seal Leakage.

1. Leakage at startup: If leakage is slight, allow pump to run several hours to let faces run in.
2. Persistent seal leakage: Faces may be cracked from freezing or thermal shock. Replace seal.

### Grinder Associated Problems.

1. Grinder will not grind: Check for proper rotation. Check condition of cutter tips and cutter ring, replace as required. Cutter ring may be inverted to provide sharp cutting edge.
2. Cutter disc interferes with stationary cutter ring: Check location of cutter ring, adjust as required. Check cutter tips for position, reposition as required. Check for bent shaft. Replace shaft, adjust cutter section and check pressure at discharge port.

## PUMP DISASSEMBLY

**WARNING:** Before disassembling pump, disconnect power source and thoroughly bleed pressure from system. Failure to do so could result in electric shock or serious bodily harm.

1. Disconnect power source.
  2. Disconnect suction and discharge piping.
  3. Remove screws (112C) holding reducer (9) to stator housing (14). Remove reducer and reducer gasket (83).
  4. Detach cutter tip (439) and cutter clamp (405) assemblies and cutter ring (196) from stator housing (14) by removing cap screws (112D). Lift cutter ring out of stator housing.
  5. Cutter tip (439) can be detached from cutter clamp (405), and cutter disc (438) by removing screw (112A).
  6. Remove cutter disc (438) by turning counterclockwise (RH thread) with drive shaft (26) locked in position. A sharp rap against cutter tip (439) with a block of wood and hammer may be required to loosen cutter disc from drive shaft (26).
  7. Remove screws (112C) holding stator housing (14) to pump body (1). Remove stator housing.
  8. Remove stator (21) by pulling off of rotor (22).
  9. Remove rotor (22) by removing pin (46) from drive shaft (26), twisting rotor may be required, with drive shaft locked in position. A suitable punch may be required to remove pin from drive shaft.
  10. Carefully slide mechanical seal (69) off shaft (26). Carefully pry seal seat out of pump body (1). If any parts of mechanical seal are worn or broken, the complete seal assembly should be replaced. Seal components are matched parts and are not interchangeable.
  11. Free collar (434) on shaft (26) by loosening set screw (435).
  12. Detach motor from pump body (1) by removing screws (112 B).
  13. The bearings (29) and shaft (26) assembly can be removed from pump body (1) after snap ring (66) has been removed. To remove the assembly, lightly tap the shaft at threaded end using a block of wood to protect the threads. The bearings may be pressed off the shaft.
- Note: When replacing bearings, always press on the inner race when assembling to shaft, and on the outer race when pressing bearings into the housings.
14. Adaptor plate (40) and adaptor plate gasket (79) can be removed from pump body by removing screws (112C).

## Parts List

Item No.	Description	Pump Model Numbers			
		†41502	42202	†43302	44402
1	Pump Body	350-0629-000			
9	Reducer	330-4196-000			
14	Stator Housing	350-0618-000			
*21	Stator	340-3501-120	340-3502-120	340-3503-120	340-3504-120
*22	Rotor	330-4605-000	330-4604-000	330-4603-000	330-4602-000
26	Drive Shaft	340-2371-000			
29	Bearing (2 req.)	630-0502-061			
40	Adaptor Plate	330-4201-000			
46	Rotor Pin	320-4486-003			320-4486-004
66	Snap Ring	320-2794-000			
*69	Mechanical Seal	320-6500-000			
77	Slinger Ring	320-6385-000			
79	Adaptor Plate Gasket	320-5888-000			
*83	Reducer Gasket	320-5878-000			
112A	Screw, SS Cap (8 req.)	320-4787-006 (8-32 x 3/8)			
112B	Screw, Hex Hd (4 req.)	619-1530-161 (3/8-16 x 1)			
112C	Screw, SS Hex Hd (18 req.)	320-5615-014 (1/4-20 x 1)			
112D	Screw, SS Cap (4 req.)	320-5395-016 (1/4-20 x 1-1/2)			
196	Cutter Ring	330-4200-000			
202	Key	320-6292-000 (3/16 x 1/4 x 3/4)			
215A	Lock Washer, SS (4 req.)	623-0010-411 (3/8)			
215B	Lock Washer, SS (18 req.)	320-5616-039 (1/4)			
405	Cutter Clamp (4 req.)	320-5887-000			
434	Coupling	320-5811-000			
435	Set Screw	606-0060-053			
438	Cutter Disc	330-4199-000			
*439	Cutter Tip (8 req.)	320-5876-000			

\* Recommended spare parts

† Not available as standard model; must be obtained by retrofitting with Repair/Conversion Kit listed below;

## REPAIR/CONVERSION KIT NUMBERS

Item No.	Description	Model 41502	Model 43302
–	Kit No.	311-9127-000	311-9128-000
22	• Rotor	330-4605-000	330-4603-000
21	• Stator	340-3501-120	340-3503-120
46	• Pin	320-4486-003	320-4486-003

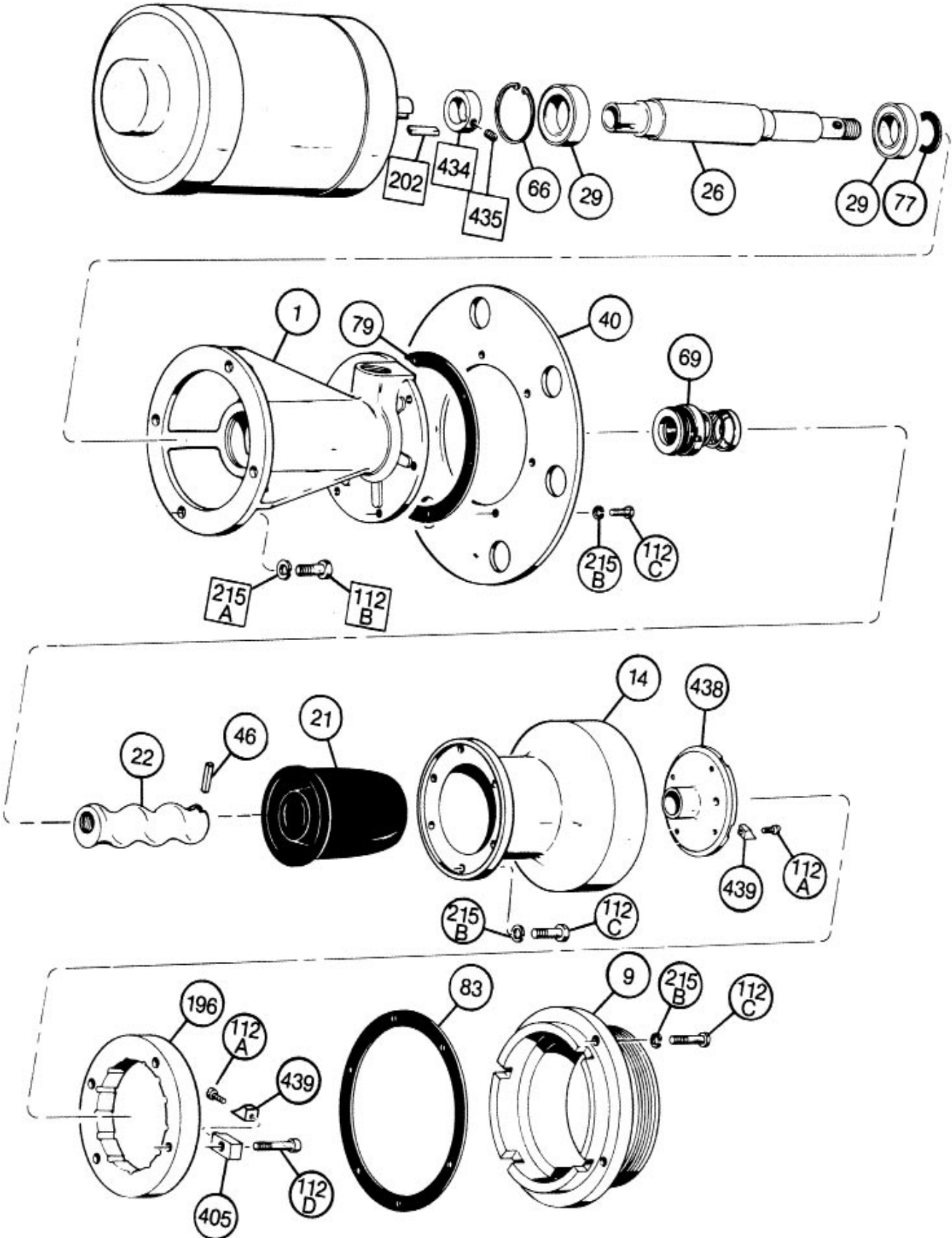

Mounting Hardware Kit

When ordering parts, please specify pump model number, pump serial number, part number, part description and quantity.

## PUMP ASSEMBLY

- Secure adaptor plate gasket (79) and adaptor plate (40) to pump body (1) using lock washers (215B) and screws (112C).
- Press bearings (29) on shaft (26), and locate slinger ring (77) near bearing on threaded end of shaft.
- Press shaft assembly into pump body (1) securing with snap ring (66).
- Install mechanical seal (69) using the following procedure:
  - Clean and oil sealing faces using clean light oil (not grease).
  - Oil the outer surface of the seal seat, and push the assembly into the bore in the pump body (1), seating it firmly and squarely.
  - After cleaning and oiling the shaft, slide the seal body along the shaft until it meets the seal seat.
  - Install seal spring and spring retainer on shaft.
- Locate pinhole on threaded end of shaft (26) and install rotor (22) on shaft. Align slot on rotor with pin hole and install pin (46).
- Secure stator (21) and stator housing (14) to pump body using lock washers (215B) and screws (112C).

**CAUTION: Be sure to use a thread locking compound on threads of screws (112 and 112C).**

- Attach cutter tips (439) to cutter disc (438) with screws (112A). See Figure 1 for correct position.
- Screw cutter tip and cutter disc assembly on drive shaft (26) in a clockwise direction (RH thread).
- Attach cutter tip (439) to cutter clamp (405) using screw (112A). See Figure 2 for correct position.

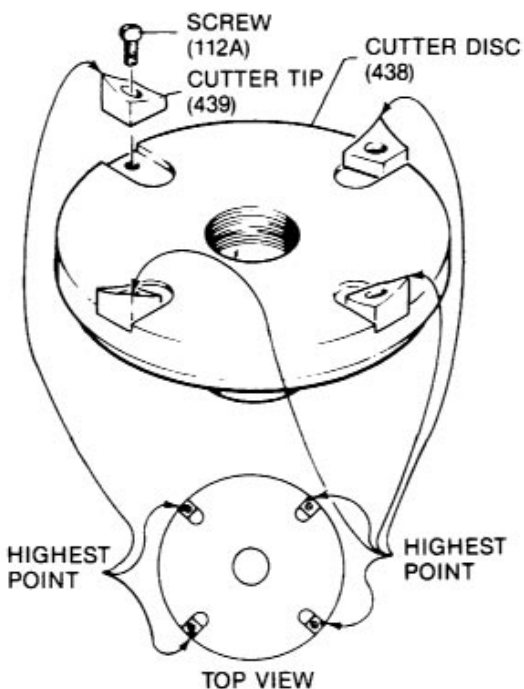

Figure 1

**CAUTION: Be sure to use a thread locking compound on threads of screws (112A).**

- Install cutter ring (196) and cutter tip/cutter clamp assemblies using the following procedure:
  - Place cutter ring (196) in stator housing (14).
  - Position cutter tip/cutter clamp assemblies on cutter ring, screwing screw (112D) finger tight. Cutter tip/cutter clamp assemblies should point to center of shaft.
  - Position cutter ring (196) to provide clearance around cutter disc (438), and tighten screws (112D). Check interference between cutter disc and cutter ring by rotating shaft several revolutions. Readjust cutter ring if necessary.
- Secure reducer gasket (83) and reducer (9) to stator housing (14) using lock washers (215B) and screws (112C). The cast tabs on the reducer (9) should be located in the spaces between the cutter tip/cutter clamp assemblies.
- Slide coupling (434) with set screw (435) over shaft (26).
- Secure motor (70) to pump body (1) using lock washers (215A) and screws (112B).
- Align keyways in motor and pump shafts, and insert key (202).

**CAUTION: Use only the rectangular key (202) supplied with hardware kit to prevent damage to shafts.**

- Secure key (202) by tightening set screw (435) in coupling (434) against the key.
- Proceed as in installation instructions.

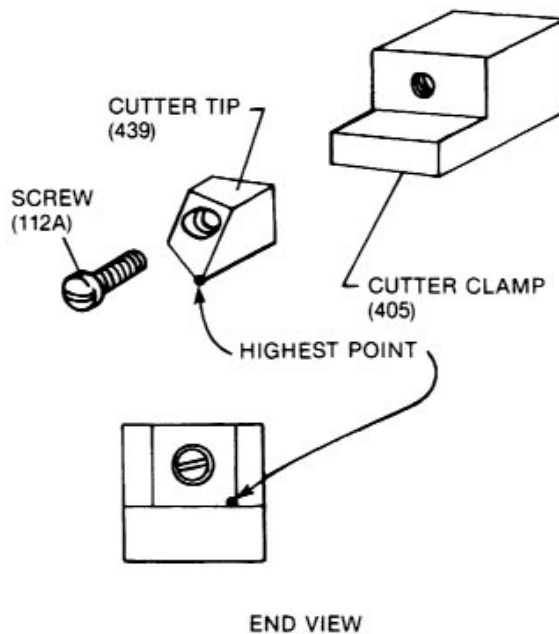

Figure 2

