

OPERATING INSTRUCTIONS

This pump has been tested prior to shipment from factory. The oil reservoir has been partially filled at testing with air motor lubricant and should be completely filled before operation. When reservoir is full, the pump will not require refilling for approximately 50 hours of use. (See Lubrication Instructions.)

OPERATION

Your SludgeMaster is equipped with a muffler located at side of unit. Air exhaust port is located at top of muffler and a 3/4" NPT thread is provided to extend exhaust port above liquid being pumped. **Exhaust port must be extended above liquid to prevent liquid and foreign material from entering air motor when not in operation.** This can be done with a standard pipe, rigid plastic pipe, or hose as desired.

Connect air supply to air inlet fitting and submerge into liquid to be pumped. Unit requires 70 CFM maximum at 80 PSI (5.51 bar) air pressure. Operation at pressures in excess of 120 PSI (8.27 bar) is not recommended.

When handling liquid with large stones or similar solid objects, it is desirable to run unit at full speed. This provides greater inertia for handling heavy foreign objects without stoppage due to lodging between impeller and pump casing.

Should a foreign object lodge and prevent pump from rotating, insert a rod or bar through hole provided at bottom of strainer into impeller vanes and bump impeller backwards (clockwise facing strainer end) until free. Strainer can be removed when necessary; however, this normally will not be required.

LUBRICATION

The only regular servicing required is maintaining oil reservoir which is just as important on this unit for proper lubrication as the oil supply is for an engine. A one quart capacity oil reservoir is provided for bearing and shaft seal lubrication and provides oil for automatic air motor lubricator. Five drops of oil per minute is automatically dispensed into air stream for continuous air motor lubrication and to prevent rust formation due to moisture which is present in any air supply. Check and refill reservoir to oil fill plug level regularly with **Shell TELLUS®T Oil 32 Premium Multigrade AW Hydraulic Oil air motor lubricant**, or an equivalent lightweight oil with rust inhibitor. The automatic oiler will consume approximately 1 pint (473 cc) of oil in 50 hours of operation. Oil reservoir should be completely drained and refilled after approximately 100 hours operation to remove accumulated moisture.

It is beneficial to pour a little oil into air inlet connection and run for a few minutes before storing for long periods.

This unit is not harmed by running without liquid.

DISASSEMBLY

Remove upper row of six bolts and lift off air motor and upper housing assembly. Filter element and filter housing are now exposed and can be removed. Lower half of jaw type coupling is threaded on pump shaft and is removed by inserting drift pin through hole in shaft to prevent rotation while turning coupling counterclockwise with pipe wrench. **DO NOT USE JAWS OF COUPLING TO LOOSEN AS THEY CAN BE BROKEN.**

Remove spacer (item 25 on Repair Parts List) from shaft and remove governor housing assembly by lifting with screwdriver from each side. This is done by inserting screwdriver under male connectors (see Figure 1) and prying down on intermediate housing. Intermediate housing can now be removed by removing lower row of six bolts.



IMPORTANT

Read these safety warnings and instructions in this manual completely, before installation and start-up of the pump. It is the responsibility of the purchaser to retain this manual for reference. Failure to comply with the recommendations stated in this manual will damage the pump, and void factory warranty.



WARNING

Airborne particles and loud noise hazards. Wear ear and eye protection.



Figure 1



Figure 2

Remove strainer assembly secured with four cap nuts. Impeller is removed by inserting block of wood, hammer handle, or similar object between impeller vane and pump casing (see Figure 2) to prevent rotation and turn shaft counterclockwise from air motor end with drift pin inserted through hole in shaft. Remove shaft assembly from volute casing by removing snap ring above oil seal, bump shaft and bearing from casing. Rotating portion of shaft seal can now be removed from shaft and stationary seal seat can be removed from casing.

REASSEMBLY

When installing shaft seal on shaft use a lightweight oil and locate seal at extreme end of shaft so that carbon face of seal will contact seal seat before bearing enters housing bore during assembly. This eliminates the possibility of carbon washer falling out of position in seal cage while bumping shaft and bearing assembly into correct position. Push oil seal and retainer into bore above bearing and install snap ring. Install governor weights, spool and spring if removed. Lay o-ring into casing bore and install intermediate housing. Install o-ring and drop governor housing into position and push down into place. Slide sleeve and spacer onto shaft with spacer and shaft holes in alignment. Install coupling and tighten securely with drift pin and pipe wrench with same procedure as removal. (See Figure 3.) Insert o-ring into filter housing bore and press filter element and housing into position as shown. (See Figure 4.) Install o-ring into intermediate bore and o-ring on to counter bore at upper end of filter housing. Assembly is now ready to receive air motor and housing assembly. If coupling half on air motor shaft is removed, make certain coupling is relocated to correct position as indicated dimensionally in Figure 5. Line up coupling jaws for engagement by using bolt holes of castings as a reference. Rubber spider should be installed in lower coupling half. Lower air motor and housing into place slowly to feel for correct coupling engagement. When coupling is properly engaged, assembly can be pushed down by hand. **DO NOT FORCE ASSEMBLY TOGETHER WITH BOLTS.** If air motor assembly is lifted back up in attempting to engage blind coupling, make certain that o-ring on top end of filter housing is still in position. If o-ring is out of position during this blind assembly, air will by-pass the governor and over-speeding can occur. Fill with recommended oil and run unit without pumping to check for possible oil leakage at shaft seal or o-ring joints. Turn air supply on slowly to make certain that governor is operating properly.

WARRANTY

This unit is guaranteed for a period of five years against defective material and workmanship.

PERMANENT INSTALLATIONS

NOTE: As mentioned, the SMA3-A pump does require that oil be in the reservoir for bearing and motor lubrication. For permanent installations remove item 66, then plug the hole with a $\frac{1}{8}$ " pipe plug, part number 618-002-330. Fill the reservoir and make sure that an in-line oiler (type oil as recommended) is used in the air supply to the pump. Set lubricator at a usage rate of 1 pint (473 cc) every 50 hours. The motor will then be lubricated by the in-line oiler and the bearing by the oil in the reservoir.

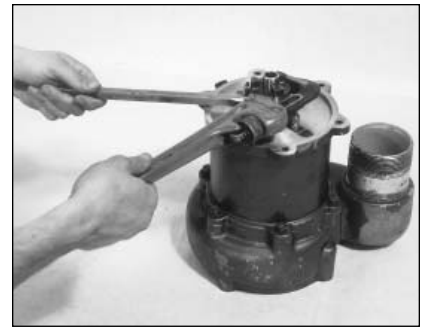

Figure 3



Figure 4

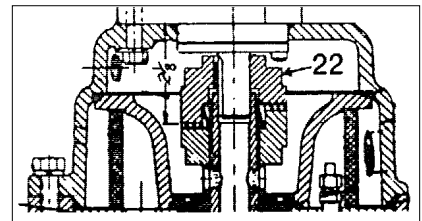

Figure 5

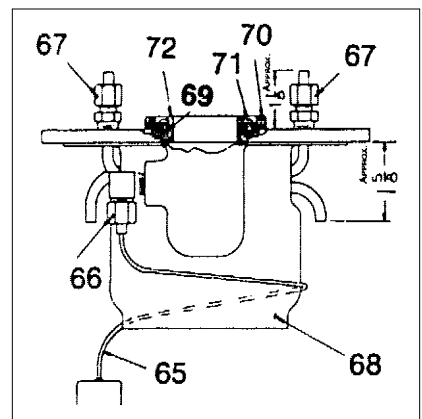

Figure 6 Spider insert.

ITEM NO.	PART NUMBER	DESCRIPTION	TOTAL RQD.		
1	180-002-155	Volute Casing	1	Repair Parts shown in bold face (darker) type are more likely to need replacement after extended periods of normal use. They are readily available from most Warren Rupp distributors. The pump owner may prefer to maintain a limited inventory of these parts in his own stock to reduce repair downtime to a minimum.	
2	258-003-010	Suction Cover	1		
3	444-002-010	Impeller	1		
4	612-002-080	Wear Plate	1		
5	430-008-155	Motor Housing	1		
6	775-002-155	Filter Spool	1		
7	800-003-330	Strainer Assembly	1		
8	430-007-155	Intermediate Housing	1		
9	730-009-120	Shaft	1		
10	430-010-150	Bearing Housing	1		
11	720-002-000	Shaft Seal	1		
12	070-002-000	Ball Bearing	1		
13	755-001-000	Sleeve	2		
14	552-001-000	Oil Seal	1		
15	670-004-162	Seal Retainer	1		
16	914-002-330	Governor Weight	2		
17	590-002-115	Governor Pin	1		
18	675-001-115	Retaining Ring	2		
19	775-003-162	Governor Spool	1		
20	780-002-115	Governor Spring	1		
21	670-003-115	Spring Retainer	1		
22	255-001-000	Coupling Assembly	1		
22-1	770-013-000	Spider Insert (see Figure 6)	1		
23	320-002-000	Filter Element	1		
25	770-001-162	Spacer	1		
26	525-003-000	Air Motor Assembly	1		
Consists of:					
26-1	AD-665	Body	1	IMPORTANT: When ordering repair parts always furnish pump model number, serial number and type number.	
26-2	AD-666	End Plate, Drive	1		
26-3	AD-651	End Plate, Dead	1		
26-4	AD-652	Rotor Assembly	1		
26-5	AD-691	Vane	4		
26-6	AD-692	Spring, Vane	4		
26-7	AD-655-A	Push Pin	2		
26-8	AD-638-A	Bearing, Drive	1		
26-9	AC-437	Bearing, Dead	1		
26-10	AC-849	Seal, Shaft	1		
26-11	AB-162	Pin, Dowel	5		
26-12	AD-641-F	Gasket, End Plate	2		
26-13	AD-642-A	End Cap, Dead	1		
26-14	AD-643	End Cap, Dead	1		
26-15	AD-644	End Cap, Gasket	1		
26-16	560-003-360	O-Ring	1		
27	530-001-000	Muffler Assembly	1		
Consists of:					
27-1	560-199-360	O-Ring	2		
27-2	538-001-555	Nipple	1		
27-3	860-009-150	Tube	1		
27-4	165-001-155	Cap, Upper	1		
27-5	165-002-155	Cap, Lower	1		
27-6	685-001-080	Rod	1		
27-7	546-002-115	Cap Nut	1		
27-8	901-024-180	Sealing Washer	2		

Repair Parts shown in **bold face (darker)** type are more likely to need replacement after extended periods of normal use. They are readily available from most Warren Rupp distributors. The pump owner may prefer to maintain a limited inventory of these parts in his own stock to reduce repair downtime to a minimum.

IMPORTANT: When ordering repair parts always furnish pump model number, serial number and type number.

MATERIAL CODES The Last 3 Digits of Part Number

000...	Assembly, sub-assembly; and some purchased items
010...	Cast Iron
015...	Ductile Iron
080...	Carbon Steel, AISI B-1112
100...	Alloy 10
110...	Alloy Type 316 Stainless Steel
112...	Alloy "C"
114...	303 Stainless Steel
115...	302/304 Stainless Steel
117...	440-C Stainless Steel (Martensitic)
120...	416 Stainless Steel (Wrought Martensitic)
123...	410 Stainless Steel (Wrought Martensitic)
148...	Hardcoat Anodized Aluminum
149...	2024-T4 Aluminum
150...	6061-T6 Aluminum
151...	6063-T6 Aluminum
152...	2024-T4 Aluminum (2023-T351)
154...	Almag 35 Aluminum
155 or 156...	.356-T6 Aluminum
157...	Die Cast Aluminum Alloy #380
159...	Anodized Aluminum
162...	Brass, Yellow, Screw Machine Stock
165...	Cast Bronze, 85-5-5-5
170...	Bronze, Bearing Type, Oil Impregnated
180...	Copper Alloy
310...	PVDF Coated
330...	Plated Steel
331...	Chrome Plated Steel
332...	Electroless Nickel Plated
335...	Galvanized Steel
354...	Injection Molded #203-40 Santoprene — Duro 40D +/-5. Color coded: RED
357...	Rupplon (Urethane Rubber) Color coded: PURPLE (Injection mold)
358...	Rupplon (Urethane Rubber) Color coded: PURPLE (Some Applications) (Compression Mold)
360...	Nitrile Rubber. Color coded: RED
363...	FKM (Fluorel). Color coded: YELLOW
364...	E.P.D.M. Rubber. Color coded: BLUE
365...	Neoprene Rubber. Color coded: GREEN
366...	Food Grade Neoprene. Color coded: WHITE
370...	Butyl Rubber. Color coded: BROWN
405...	Cellulose Fibre
408...	Cork and Neoprene
425...	Compressed Fibre
465...	Fibre
500...	Delrin 500
505...	Acrylic Resin Plastic
540...	Nylon
550...	Polyethylene
555...	PVC
570...	Rulon II
580...	Ryton
590...	Valox
591...	Nylatron G-S
592...	Nylatron NSB
600...	PTFE (virgin material) Tetrafluorocarbon (TFE)
601...	PTFE (Bronze and moly filled)
602...	Filled PTFE
603...	Blue Gylon
604...	PTFE — Diaphragm

ITEM NO.	PART NUMBER	DESCRIPTION	TOTAL RQD.
28	406-001-000	Handle Assembly	1
29	866-007-162	Male Connector	2
30	312-007-180	Elbow	1
31	200-004-330	Muffler Clamp	1
32	115-004-080	Bracket	1
33	254-004-000	Coupler	1
35	312-006-000	Elbow, Motor	1
36	312-004-162	Elbow, Motor Housing	1
37	200-005-115	Hose Clamp	2
38	427-006-000	Hose, 3/4 I.D.	1
39	675-006-000	Retaining Ring	1
40	675-005-000	Retaining Ring	1
41	675-003-080	Retaining Ring	2
42	360-004-440	Gasket	6 Minimum
43	560-013-360	O-Ring	1
44	560-007-360	O-Ring	1
45	560-012-360	O-Ring	1
46	560-009-360	O-Ring	2
47	560-006-360	O-Ring	1
48	560-008-360	O-Ring	1
49	560-005-360	O-Ring	1
51	618-005-330	Pipe Plug 1/2" NPT	1
52	312-008-335	Street Elbow	1
53	170-033-330	Capscrew	4
54	170-006-330	Capscrew	12
55	170-005-330	Capscrew	3
56	546-001-115	Cap Nut	2
57	170-002-330	Capscrew	1
58	545-003-330	Hex Nut	2
59	900-001-330	Lock Washer	5
60	901-014-180	Washer, Sealing	3
61	901-009-330	Flat Washer	2
62	900-005-330	Lock Washer	11
63	170-007-115	Capscrew	2
64	901-024-180	Sealing Washer	2
65	861-001-000	Metering Tube Assembly	1
66	312-003-000	Elbow	1
67	866-006-162	Male Connector	2
68	430-009-155	Governor Housing	1
69	560-011-360	O-Ring	1
70	670-002-162	Retainer, Seal Ring	1
71	675-004-000	Ring, Retainer	1
72	675-002-165	Seal Ring	1
73	740-002-115	Shim (.010)	3
74	740-003-115	Shim (.030)	2
75	901-005-330	Flat Washer 3/8"	4
76	170-008-115	Capscrew	10
77	860-022-180	Tubing, Soft Copper	2
78	170-063-330	Capscrew, Hex Head	1
	535-069-000	(NOT SHOWN)	1
	710-010-115	(NOT SHOWN)	4

Repair Parts shown in **bold face (darker)** type are more likely to need replacement after extended periods of normal use. They are readily available from most Warren Rupp distributors. The pump owner may prefer to maintain a limited inventory of these parts in his own stock to reduce repair downtime to a minimum.

IMPORTANT: When ordering repair parts always furnish pump model number, serial number and type number.

MATERIAL CODES

The Last 3 Digits of Part Number

000...	Assembly, sub-assembly; and some purchased items
010...	Cast Iron
015...	Ductile Iron
080...	Carbon Steel, AISI B-1112
100...	Alloy 10
110...	Alloy Type 316 Stainless Steel
112...	Alloy "C"
114...	303 Stainless Steel
115...	302/304 Stainless Steel
117...	440-C Stainless Steel (Martensitic)
120...	416 Stainless Steel (Wrought Martensitic)
123...	410 Stainless Steel (Wrought Martensitic)
148...	Hardcoat Anodized Aluminum
149...	2024-T4 Aluminum
150...	6061-T6 Aluminum
151...	6063-T6 Aluminum
152...	2024-T4 Aluminum (2023-T351)
154...	Almag 35 Aluminum
155 or 156...	356-T6 Aluminum
157...	Die Cast Aluminum Alloy #380
159...	Anodized Aluminum
162...	Brass, Yellow, Screw Machine Stock
165...	Cast Bronze, 85-5-5-5
170...	Bronze, Bearing Type, Oil Impregnated
180...	Copper Alloy
310...	PVDF Coated
330...	Plated Steel
331...	Chrome Plated Steel
332...	Electroless Nickel Plated
335...	Galvanized Steel
354...	Injection Molded #203-40 Santoprene — Durol 40D +/-5, Color coded: RED
357...	Rupplon (Urethane Rubber) Color coded: PURPLE (Injection mold)
358...	Rupplon (Urethane Rubber) Color coded: PURPLE (Some Applications) (Compression Mold)
360...	Nitrile Rubber, Color coded: RED
363...	FKM (Fluorel), Color coded: YELLOW
364...	E.P.D.M. Rubber, Color coded: BLUE
365...	Neoprene Rubber, Color coded: GREEN
366...	Food Grade Neoprene, Color coded: WHITE
370...	Butyl Rubber, Color coded: BROWN
405...	Cellulose Fibre
408...	Cork and Neoprene
425...	Compressed Fibre
465...	Fibre
500...	Delrin 500
505...	Acrylic Resin Plastic
540...	Nylon
550...	Polyethylene
555...	PVC
570...	Rulon II
580...	Ryton
590...	Valox
591...	Nylatron G-S
592...	Nylatron NSB
600...	PTFE (virgin material) Tetrafluorocarbon (TFE)
601...	PTFE (Bronze and moly filled)
602...	Filled PTFE
603...	Blue Gylon
604...	PTFE — Diaphragm

