

**WARREN
RUPP®**

IDEX
FLUID & METERING

SANDPIPER®
A WARREN RUPP PUMP BRAND

SERVICE and OPERATING MANUAL



II 2GD T5



Model SSA2-A
Type 4

Table of Contents

Principle of Operation	1
Installation and Start-Up	1
Air Supply	1
Air Inlet & Priming	2
ESADS+Plus®: Externally Serviceable Air Distribution System	2
Air Exhaust	3
Between Uses	3
Check Valve Servicing	3
Diaphragm Servicing	3
Reassembly	3
Pilot Valve	4
Pilot Valve Actuator	4
Service Instructions: Troubleshooting	5
Warranty	5
Important Safety Information	6
Recycling	6
Grounding The Pump	7
Material Codes	8
Declaration of Conformity	9
Composite Repair Parts List	10-11
Composite Repair Drawing	12

**WARREN
RUPP®****IDEX**
FLUID & METERING**SANDPIPER®**
A WARREN RUPP PUMP BRAND

II 2GD T5

**Model SSA2-A**
Type 4

PRINCIPLE OF PUMP OPERATION

This flap swing check valve pump is powered by compressed air and is a 1:1 pressure ratio design. It alternately pressurizes the inner side of one diaphragm chamber, while simultaneously exhausting the other inner chamber. This causes the diaphragms, which are connected by a common rod, to move endwise. Air pressure is applied over the entire surface of the diaphragm, while liquid is discharged from the opposite side. The diaphragm operates under a balanced condition during the discharge stroke, which allows the unit to be operated at discharge heads over 200 feet (61 meters) of water head.

Since the diaphragms are connected by a common rod, secured by plates to the center of the diaphragms, one diaphragm performs the discharge stroke, while the other is pulled to perform the suction stroke in the opposite chamber.

For maximum diaphragm life, keep the pump as close to the liquid being pumped as possible. Positive suction head in excess of 10 feet of liquid (3.048 meters) may require a back pressure regulating device. This will maximize diaphragm life.

Alternate pressuring and exhausting of the diaphragm chamber is performed by means of an externally mounted, pilot operated, four-way spool type air distribution valve. When the spool shifts to one end of the valve body, inlet air pressure is applied to one diaphragm chamber and the other diaphragm chamber exhausts. When the spool shifts to the opposite end of the valve body, the porting of chambers is reversed. The air distribution valve spool is moved by an internal pilot valve which alternately pressurizes one side of the air distribution valve spool, while exhausting the other side. The pilot valve is shifted at each end of the diaphragm stroke by the diaphragm plate coming in contact with the end of the pilot spool. This pushes it into position for shifting of the air distribution valve.

The chambers are manifolded together with a suction and discharge flap-type check valve for each chamber, maintaining flow in one direction through the pump.

INSTALLATION & START-UP

Locate the pump as close to the product being pumped as possible, keeping suction line length and number of fittings to a minimum. Do not reduce line size.

For installations of rigid piping, short flexible sections of hose should be installed between pump and piping. This reduces vibration and strain to the piping system. A Warren Rupp Tranquilizer® surge suppressor is recommended to further reduce pulsation in flow.

This pump was tested at the factory prior to shipment and is ready for operation. It is completely self-priming from a dry start for suction lifts of 20 feet (6.096 meters) or less. For suction lifts exceeding 20 feet of liquid, fill the chambers with liquid prior to priming.

AIR SUPPLY

Air supply pressures cannot exceed 125 psi (8.61 bar). Connect the pump air inlet to an air supply of sufficient capacity and pressure required for desired performance. When the air line is solid piping, use a short length of flexible hose [not less than $\frac{3}{4}$ " (19mm) in diameter] between pump and piping to eliminate strain to pipes.

AIR INLET & PRIMING

For start-up, open an air valve approximately $\frac{1}{2}$ to $\frac{3}{4}$ turn. After the unit primes, an air valve can be opened to increase flow as desired. If opening the valve increases cycling rate, but does not increase flow rate, cavitation has occurred, and the valve should be closed slightly.

For the most efficient use of compressed air and the longest diaphragm life, throttle the air inlet to the lowest cycling rate that does not reduce flow.

A NOTE ABOUT AIR VALVE LUBRICATION

The SandPiper pump's pilot valve and main air valve assemblies are designed to operate WITHOUT lubrication. This is the preferred mode of operation. There may be instances of personal preference, or poor quality air supplies when lubrication of the compressed air supply is required. The pump air system will operate with properly lubricated compressed air supplies. Proper lubrication of the compressed air supply would entail the use of an air line lubricator (available from Warren Rupp) set to deliver one drop of 10 wt., non-detergent oil for every 20 SCFM of air the pump consumed at its point of operation. Consult the pump's published Performance Curve to determine this.

It is important to remember to inspect the sleeve and spool set routinely. It should move back and forth freely. This is most important when the air supply is lubricated. If a lubricator is used, oil accumulation will, over time, collect any debris from the compressed air. This can prevent the pump from operating properly.

Water in the compressed air supply can create problems such as icing or freezing of the exhaust air causing the pump to cycle erratically, or stop operating. This can be addressed by using a point of use air dryer to supplement a plant's air drying equipment. This device will remove excess water from the compressed air supply and alleviate the icing or freezing problem.

ESADS: EXTERNALLY SERVICEABLE AIR DISTRIBUTION SYSTEM

Please refer to the exploded view drawing and parts list in the Service Manual supplied with your pump. If you need replacement or additional copies, contact your local Warren Rupp Distributor, or the Warren Rupp factory Literature Department at the number shown below. To receive the correct manual, you must specify the MODEL and TYPE information found on the name plate of the pump.

The main air valve sleeve and spool set is located in the valve body mounted on the pump with four hex head capscrews. The valve body assembly is removed from the pump by removing these four hex head capscrews.

With the valve body assembly off the pump, access to the sleeve and spool set is made by removing four hex head capscrews (each end) on the end caps of the valve body assembly. With the end caps removed, slide the spool back and forth in the sleeve. The spool is closely sized to the sleeve and must move freely to allow for proper pump operation. An accumulation of oil, dirt or other contaminants from the pump's air supply, or from a failed diaphragm, may prevent the spool from moving freely. This can cause the spool to stick in a position that prevents the pump from operating. If this is the case, the sleeve and spool set should be removed from the valve body for cleaning and further inspection.

Remove the spool from the sleeve. Using an arbor press or bench vise (with an improvised mandrel), press the sleeve from the valve body. Take care not to damage the sleeve. At this point, inspect the o-rings on the sleeve for nicks, tears or abrasions. Damage of this sort could happen during assembly or servicing. A sheared or cut o-ring can allow the pump's compressed air supply to leak or bypass within the air valve assembly, causing the pump to leak compressed air from the pump air exhaust or not cycle properly. This is most noticeable at pump dead head or high discharge pressure conditions. Replace any of these o-rings as required or set up a routine, preventive maintenance schedule to do so on a regular basis. This practice should include cleaning the spool and sleeve components with a safety solvent or equivalent, inspecting for signs of wear or damage, and replacing worn components.

To re-install the sleeve and spool set, lightly lubricate the o-rings on the sleeve with an o-ring assembly lubricant or lightweight oil (such as 10 wt. air line lubricant). Re-install one end cap, gasket and bumper on the valve body. Using the arbor press or bench vise that was used in disassembly, carefully press the sleeve back into the valve body, without shearing the o-rings. You may have to clean the surfaces of the

valve body where the end caps mount. Material may remain from the old gasket. Old material not cleaned from this area may cause air leakage after reassembly. Take care that the bumper stays in place allowing the sleeve to press in all the way. Reinstall the spool, opposite end cap, gasket and bumper on the valve body. After inspecting and cleaning the gasket surfaces on the valve body and intermediate, reinstall the valve body on the pump using new gaskets. Tighten the four hex head capscrews evenly and in an alternating cross pattern.

AIR EXHAUST

If a diaphragm fails, the pumped liquid or fumes can enter the air end of the pump, and be exhausted into the atmosphere. When pumping hazardous or toxic materials, pipe the exhaust to an appropriate area for safe disposition.

This pump can be submerged if materials of construction are compatible with the liquid. The air exhaust must be piped above the liquid level. Piping used for the air exhaust must not be smaller than 1" (2.54 cm). Reducing the pipe size will restrict air flow and reduce pump performance. When the product source is at a higher level than the pump (flooded suction), pipe the exhaust higher than the product source to prevent siphoning spills.

Freezing or icing-up of the air exhaust can occur under certain temperature and humidity conditions. Use of an air dryer unit should eliminate most icing problems.

BETWEEN USES

When used for materials that tend to settle out or transform to solid form, the pump should be completely flushed after each use, to prevent damage. Product remaining in the pump between uses could dry out or settle out. This could cause problems with valves and diaphragms at re-start. In freezing temperatures, the pump must be drained between uses in all cases.

CHECK VALVE SERVICING

Valve inspection requires removal of the ten hand knobs around the outer chamber. Once the knobs have been removed the outer chamber can be pulled away exposing the flap valves and valve seats. Visual inspection and removal is possible. The flap valve should be free to swing on the valve seat. Any obstruction should be removed. The opposite side check valves can be inspected by following same procedure.

The flap valve can be disassembled by removing the seal retainer. This makes it possible to inspect the seal ring, retainer and flap valve. Upon reassembly, torque the retainer (item 28-3) into the flap valve (item 28-1) to a maximum of 43 ft/lbs. (58.30 Newton meters).

DIAPHRAGM SERVICING

To inspect or remove a diaphragm the ten hand knobs around the chamber flange must be backed off. Pulling the outer chamber away exposes the diaphragm. Use care to keep foreign matter from behind the diaphragm. The opposite diaphragm may be inspected by the same procedure.

To remove diaphragms, hold the diaphragm plate opposite to the diaphragm you wish to remove. Unthread the outer plate on the diaphragm being replaced. Once plate is removed, the diaphragm assembly will pull out of the bracket. Now the shaft, shaft seal, and pilot valve actuator bushings are easily inspected.

REASSEMBLY

All procedures for reassembling the pump are the reverse of the previous instructions with further instructions as shown:

1. Attach an -030- diaphragm to one end of the pump's diaphragm rod (685-033-120) utilizing the threads of the outer diaphragm plate (612-197-111). The natural sequence of parts in the assembly is outer diaphragm plate, diaphragm and inner diaphragm plate. Tighten the assembly by hand. Install the diaphragm bumper (132-002-360) on the diaphragm rod and install the assembly into the pump. Attach the pump's outer chamber to this side, securing it in place with the fasteners. Install the second diaphragm and its components to the opposite side of the pump in the same sequence. Tighten the assembly to a torque value of 40 ft. lbs. (54.23 Newton meters). You can finish the pump assembly at this point after any additional maintenance is completed.

To achieve the best diaphragm life, the components must be installed properly. The diaphragms themselves are to be installed with their natural bulge facing the outside of the pump. It is important that the assemblies are tightened properly at installation. Use water as a lubricant between the diaphragm assembly components. This will allow the parts to slide freely against each other as the assembly is tightened. This reduction in friction will preclude any false torque readings that may occur at assembly. Best assembly practice would let the assembly sit idle for a short period of time (1 to 5 minutes) and then retighten to the original torque rating. This allows for any stress relaxation to be compensated for as the elastomer in the diaphragm initially responds to the clamp load.

2. For a bottom discharge pump the outer chamber should be installed with the counterbored end at the bottom. It should be on top for a top discharge ported pump. Place one outer chamber onto the inner chamber studs. Turn the hand knobs clockwise gradually and evenly around the outer chamber until snug.
3. Next, the flap valves should be placed on the seat with the hinge pins in the seat groove. Firmly push the wear ring onto the seat over the hinge pins of the flap valve. This should hold the flap valve on the seat during assembly. Make sure the seat o-ring and sealing ring are in place. Install the seat, with the flap valve in place, in the counterbored suction manifold and out chamber. The flap valves should always hang down. Position the counterbored manifold, with seats in place, into the outer chamber. Turn the handle assemblies clockwise onto the manifold studs until snug. Then position the other manifold or discharge manifold over the seat and flap valve already in the outer chamber. Turn two more handle assemblies until snug.
4. The opposite outer chamber, with a seat installed into the counterbore and diaphragm in place, can now be placed onto the inner chamber studs. Position the seats and manifolds so that the outer chamber fits together. Then tighten down the hand knobs gradually (again turning clockwise) and evenly on both sides.
5. Finally torque the hand knobs evenly on both sides of the pump to a maximum of 500 inch-pounds (42 foot pounds) (56.49 Newton meters).
6. If the pump is a bottom discharge ported pump, to change pump porting to top discharge by removing both outer chambers and manifolds. Once the outer chambers are removed, rotate one chamber 180° and replace on the inner chamber studs. The counterbored end of the outer chamber should now be at the top. Turn the hand knobs clockwise gradually and evenly around the outer chamber until snug. Next perform step 3 above. Then rotate the other outer chamber 180° to match the first one and perform steps 4 and 5.

PILOT VALVE

The pilot valve assembly is accessed by removing the main air distribution valve body from the pump and lifting the pilot valve body out of the intermediate housing.

Most problems with the pilot valve can be corrected by replacing the o-rings. Always grease the spool prior to inserting it into the sleeve. If the sleeve is removed from the body, reinsertion must be at the chamfered side. Grease the o-rings to slide the sleeve into the valve body. Securely insert the retaining ring around the sleeve. When reinserting the pilot valve, push both plungers (located inside the intermediate bracket) out of the path of the pilot valve spool ends to avoid damage.

PILOT VALVE ACTUATOR

Bushings for the pilot valve actuators are threaded into the intermediate bracket from the outside. The plunger may be removed for inspection or replacement. First remove the air distribution valve body and the pilot valve body from the pump. The plungers can be located by looking into the intermediate. It may be necessary to use a fine piece of wire to pull them out. The bushing can be turned out through the inner chamber by removing the outer chamber assembly. Replace the bushings if pins have bent.

RECOMMENDED WARREN RUPP ACCESSORIES TO MAXIMIZE PUMP PERFORMANCE:

- **Tranquilizer® Surge Suppressor: For nearly pulse-free flow.**
- **Warren Rupp Filter/Regulator: For modular installation and service convenience.**
- **Warren Rupp Speed Control: For manual or programmable process control. Manual adjustment or 4-20mA reception.**

For more detailed information on these accessories, contact your local Warren Rupp Factory-Authorized Distributor, or Warren Rupp corporate headquarters.

TROUBLESHOOTING

PROBLEM: Pump cycles but will not pump. (Note: higher suction lifts require faster cycling speed for priming.)

POSSIBLE CAUSES:

- A. Air leak in suction line.
- B. Excessive suction lift.
- C. Check valve not seating properly.
- D. Leakage at joint of suction manifold or elbow flange.
- E. Suction line or strainer plugged.
- F. Diaphragm ruptured.

PROBLEM: Pump will not cycle. (Note: Always disconnect air supply to relieve air pressure before disassembling any portion of pump.)

POSSIBLE CAUSES:

- A. Discharge hose or line plugged, or discharge head requirement greater than air supply pressure. (Disconnect discharge line to check.)
- B. Spool in air distribution valve not shifting. (Remove end cap and check spool — must slide freely.)
- C. Diaphragm ruptured. (Air will escape out discharge line in this case.)
- D. Blockage in diaphragm chamber preventing movement. (Shut off air supply and reopen after pressure is relieved.)

PROBLEM: Uneven discharge flow. (Indicates one chamber not operating properly.)

POSSIBLE CAUSES:

- A. Check valve not sealing properly in one chamber.
- B. Diaphragm failure in one chamber.
- C. Air leak at suction manifold joint or elbow flange one side.

WARRANTY:

This unit is guaranteed for a period of five years against defective material and workmanship.

The following, currently available complete 'Wet End Kits' have been modified to include the parts required to change diaphragms out to the newer part number.

476-044-366	Wet End Kit SSA2-A	Food Grade Nitrile
476-044-368	Wet End Kit SSA2-A	Food Grade EPDM

These kits now include the -030- style diaphragm (2 each) and the 612-197-111 outer diaphragm plate (2 each). These kits will apply to SSA2-A units with serial numbers up to 586310.

For SSA2-A units with serial numbers 586311 and above, use the following partial Wet End Kits:

476-168-366	Wet End Kit SSA2-A	Food Grade Nitrile
476-168-368	Wet End Kit SSA2-A	Food Grade EPDM

Note: When either of these kits are ordered, they do not include the 612-197-111 outer diaphragm plates.

476-167-366	Include 619-197-111/612-198-150/286-030-366 or 368
476-167-368	(used to change out Diaphragm Plate System)

476-179-366	Include 619-197-113/612-198-150/286-030-366 or 368
476-179-368	(used to change out Diaphragm Plate System)

IMPORTANT SAFETY INFORMATION



IMPORTANT

Read these safety warnings and instructions in this manual completely, before installation and start-up of the pump. It is the responsibility of the purchaser to retain this manual for reference. Failure to comply with the recommendations stated in this manual will damage the pump, and void factory warranty.



WARNING

Take action to prevent static sparking. Fire or explosion can result, especially when handling flammable liquids. The pump, piping, valves, containers or other miscellaneous equipment must be grounded. (See page 8)



WARNING

This pump is pressurized internally with air pressure during operation. Always make certain that all bolting is in good condition and that all of the correct bolting is reinstalled during assembly.



CAUTION

Before pump operation, inspect all gasketed fasteners for looseness caused by gasket creep. Retorque loose fasteners to prevent leakage. Follow recommended torques stated in this manual.



WARNING

When used for toxic or aggressive fluids, the pump should always be flushed clean prior to disassembly.



WARNING

Before maintenance or repair, shut off the compressed air line, bleed the pressure, and disconnect the air line from the pump. The discharge line may be pressurized and must be bled of its pressure.



WARNING

Before doing any maintenance on the pump, be certain all pressure is completely vented from the pump, suction, discharge, piping, and all other openings and connections. Be certain the air supply is locked out or made non-operational, so that it cannot be started while work is being done on the pump. Be certain that approved eye protection and protective clothing are worn all times in the vicinity of the pump. Failure to follow these recommendations may result in serious injury or death.



WARNING

In the event of diaphragm rupture, pumped material may enter the air end of the pump, and be discharged into the atmosphere. If pumping a product which is hazardous or toxic, the air exhaust must be piped to an appropriate area for safe disposition.



WARNING

Airborne particles and loud noise hazards. Wear ear and eye protection.

RECYCLING

Many components of SANDPIPER® AODD pumps are made of recyclable materials (see chart on page 9 for material specifications). We encourage pump users to recycle worn out parts and pumps whenever possible, after any hazardous pumped fluids are thoroughly flushed.

PUMP COMPLIES WITH EN809 PUMPING DIRECTIVE, DIRECTIVE 98/37/EC SAFETY OF MACHINERY, AND DIRECTIVE 94/9/EC, EN13463-1 EQUIPMENT FOR USE IN POTENTIALLY EXPLOSIVE ENVIRONMENTS. FOR REFERENCE TO THE DIRECTIVE CERTIFICATES VISIT: WWW.WARRENRUPP.COM. THE TECHNICAL FILE NO. AX1 IS STORED AT KEMA, NOTIFIED BODY 0344, UNDER DOCUMENT #203040000.



II 2GD T5

Grounding The Pump

⚠ WARNING ⚠

Take action to prevent static sparking. Fire or explosion can result, especially when handling flammable liquids. The pump, piping, valves, containers or other miscellaneous equipment must be grounded.

THE CLAMP END IS INSTALLED TO A TRUE EARTH GROUND.

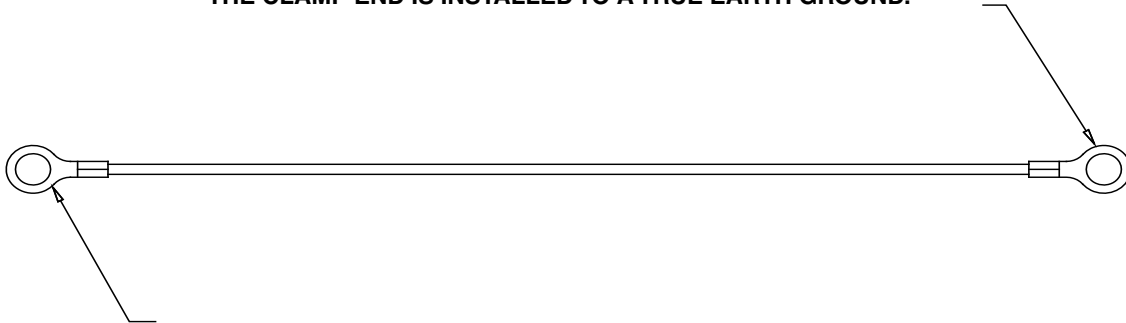

THE EYELET END IS FASTENED TO THE PUMP HARDWARE.

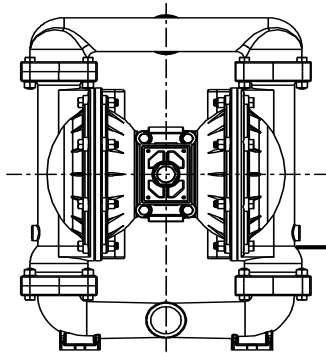

THIS 8 FOOT LONG (244 CENTIMETERS) GROUND STRAP, PART NUMBER 920-025-000 CAN BE ORDERED AS A SERVICE ITEM.

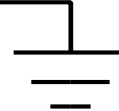

To reduce the risk of static electrical sparking, this pump must be grounded. Check the local electrical code for detailed grounding instruction and the type of equipment required, or in the absence of local codes, an industry or nationally recognized code having jurisdiction over specific installations.

MATERIAL CODES

THE LAST 3 DIGITS OF PART NUMBER

000	Assembly, sub-assembly; and some purchased items	337	Silver Plated Steel	555	Polyvinyl Chloride
010	Cast Iron	340	Nickel Plated	556	Black Vinyl
012	Powered Metal	342	Filled Nylon	558	Conductive HDPE
015	Ductile Iron	351	Food Grade Santoprene	570	Rulon II
020	Ferritic Malleable Iron	353	Geolast; Color: Black	580	Ryton
025	Music Wire	354	Injection Molded #203-40 Santoprene- Duro 40D +/-5; Color: RED	590	Valox
080	Carbon Steel, AISI B-1112	355	Thermal Plastic	591	Nylatron G-S
100	Alloy 20	356	Hytrel	592	Nylatron NSB
110	Alloy Type 316 Stainless Steel	357	Injection Molded Polyurethane	600	PTFE (virgin material) Tetrafluorocarbon (TFE)
111	Alloy Type 316 Stainless Steel (Electro Polished)	358	Urethane Rubber (Some Applications) (Compression Mold)	601	PTFE (Bronze and moly filled)
112	Alloy C	359	Urethane Rubber	602	Filled PTFE
113	Alloy Type 316 Stainless Steel (Hand Polished)	360	Nitrile Rubber Color coded: RED	603	Blue Gylon
114	303 Stainless Steel	361	Nitrile	604	PTFE
115	302/304 Stainless Steel	363	FKM (Fluorocarbon). Color coded: YELLOW	606	PTFE
117	440-C Stainless Steel (Martensitic)	364	E.P.D.M. Rubber. Color coded: BLUE	607	Envelon
120	416 Stainless Steel (Wrought Martensitic)	365	Neoprene Rubber. Color coded: GREEN	608	Conductive PTFE
123	410 Stainless Steel (Wrought Martensitic)	366	Food Grade Nitrile	610	PTFE Encapsulated Silicon
148	Hardcoat Anodized Aluminum	368	Food Grade EPDM	611	PTFE Encapsulated FKM
149	2024-T4 Aluminum	370	Butyl Rubber Color coded: BROWN	632	Neoprene/Hytrel
150	6061-T6 Aluminum	371	Philthane (Tuftane)	633	FKM/PTFE
151	6063-T6 Aluminum	374	Carboxylated Nitrile	634	EPDM/PTFE
152	2024-T4 Aluminum (2023-T351)	375	Fluorinated Nitrile	635	Neoprene/PTFE
154	Almag 35 Aluminum	378	High Density Polypropylene	637	PTFE, FKM/PTFE
155	356-T6 Aluminum	379	Conductive Nitrile	638	PTFE, Hytrel/PTFE
156	356-T6 Aluminum	405	Cellulose Fibre	639	Nitrile/TFE
157	Die Cast Aluminum Alloy #380	408	Cork and Neoprene	643	Santoprene®/EPDM
158	Aluminum Alloy SR-319	425	Compressed Fibre	644	Santoprene®/PTFE
159	Anodized Aluminum	426	Blue Gard	656	Santoprene Diaphragm and Check Balls/EPDM Seats
162	Brass, Yellow, Screw Machine Stock	440	Vegetable Fibre	661	EPDM/Santoprene
165	Cast Bronze, 85-5-5-5	465	Fibre	666	FDA Nitrile Diaphragm, PTFE Overlay, Balls, and Seals
166	Bronze, SAE 660	500	Delrin 500	668	PTFE, FDA Santoprene/PTFE
170	Bronze, Bearing Type, Oil Impregnated	501	Delrin 570		
175	Die Cast Zinc	502	Conductive Acetal, ESD-800		Delrin and Hytrel are registered tradenames of E.I. DuPont.
180	Copper Alloy	503	Conductive Acetal, Glass-Filled		Gylon is a registered tradename of Garlock, Inc.
305	Carbon Steel, Black Epoxy Coated	505	Acrylic Resin Plastic		Nylatron is a registered tradename of Polymer Corp.
306	Carbon Steel, Black PTFE Coated	506	Delrin 150		Santoprene is a registered tradename of Monsanto Corp.
307	Aluminum, Black Epoxy Coated	520	Injection Molded PVDF Natural color		Rulon II is a registered tradename of Dixon Industries Corp.
308	Stainless Steel, Black PTFE Coated	540	Nylon		Ryton is a registered tradename of Phillips Chemical Co.
309	Aluminum, Black PTFE Coated	541	Nylon		Valox is a registered tradename of General Electric Co.
310	PVDF Coated	542	Nylon		PortaPump, Tranquilizer and SludgeMaster are registered tradenames of Warren Rupp, Inc.
313	Aluminum, White Epoxy Coated	544	Nylon Injection Molded		
330	Zinc Plated Steel	550	Polyethylene		
331	Chrome Plated Steel	551	Glass Filled Polypropylene		
332	Aluminum, Electroless Nickel Plated	552	Unfilled Polypropylene		
333	Carbon Steel, Electroless Nickel Plated	553	Unfilled Polypropylene		
335	Galvanized Steel				
336	Zinc Plated Yellow Brass				

Declaration of Conformity

Declaration of Conformity

**WARREN
RUPP®**

IDEX
FLUID & METERING

Declaration of Conformity

Warren Rupp, Inc., 800 North Main Street, Mansfield, Ohio, certifies that Air-Operated Double Diaphragm Metallic Pumps Series: HDB, HDF, M Non-Metallic, S Non-Metallic, M Metallic, S Metallic, Containment Duty, Gas, UL, High Pressure, W, Submersible and Tranquilizers comply with the European Community Directive 98/37/EC, Safety of Machinery. This product has used EN 809, Pumps and Pump Units for Liquids - Common Safety Requirements harmonized standard to verify conformance.

David Roseberry
Signature of authorized person

October 20, 2005
Date of issue

David Roseberry
Printed name of authorized person

Engineering Manager
Title

CE

**WARREN
RUPP®****IDEX**
FLUID & METERING**SANDPIPER®**
A WARREN RUPP PUMP BRAND

II 2GD T5

**Model SSA2-A**
Type 4**REPAIR PARTS LIST and DRAWING**

ITEM NO.	PART NUMBER	DESCRIPTION	TOTAL RQD.
1	114-005-332	Bracket, Intermediate	1
2	560-022-360	O-Ring	2
3	070-006-170	Bearing, Sleeve	2
4	720-004-360	Seal, U-Cup	2
5	132-002-360	Bumper Diaphragm	2
6	685-033-120	Rod, Diaphragm	1
7	135-008-000	Actuator, Bushing Assembly	2
8	132-022-360	O-Ring	2
9	620-004-114	Plunger, Actuator	2
10	170-024-115	Capscrew, Hex Hd.	8
11	530-036-000	Muffler	1
12	196-036-332	Chamber, Diaphragm	2
13	807-042-115	Stud	8
14	612-198-150	Plate, Diaphragm	2
15	545-005-115	Nut, Hex	6
16	900-005-115	Washer, Lock	6
17	807-043-115	Stud with Shoulder	4
18	286-030-366	Diaphragm	2
	286-030-368	Diaphragm	2
19	196-041-111	Chamber, Outer	2
	196-041-113	Chamber, Outer	2
20	406-002-000	Knob, Locking	12
21	900-006-115	Washer, Lock	8
22	115-058-332	Bracket, Foot Mtg.	2
23	685-034-332	Rod, Connector	1
24	518-028-111	Manifold, Discharge	1
	518-028-113	Manifold, Discharge	1
25	518-029-111	Manifold, Suction	1
	518-029-113	Manifold, Suction	1
26	675-025-366	Sealing, Ring²	4
	675-025-368	Sealing, Ring ²	4
27	475-043-000	Seal Kit²	4
27-1	722-036-520	Seat, Flap Valve	4
27-2	135-015-114	Flap Bearing	8
28	338-013-366	Flap Valve Assembly² consists of:	4
	338-013-368	Flap Valve	1
28-1	336-012-111	Flap Valve	1
	336-012-113	Flap Valve	1
28-2	675-024-366	Flap Valve Seal	1
	675-024-368	Flap Valve Seal	1
28-3	670-032-111	Seal, Retainer	1
	670-032-113	Seal, Retainer	1
29	675-031-544	Ring, Wear²	4
30	560-048-366	O-Ring²	4
	560-048-368	O-Ring ²	4
31	360-041-425	Gasket, Valve Body	1
32	095-073-000	Assembly, Pilot Valve¹	1
32-A	095-070-551	Valve Body	1
32-B	755-025-000	Sleeve (without O-Ring)	1
32-C	560-033-360	O-Ring (Sleeve)	4
32-D	775-026-000	Spool (without O-Ring)	1
32-E	560-023-360	O-Ring (Spool)	2
32-F	675-037-080	Retaining Ring	1
33	360-048-425	Gasket, Valve Body	1

Repair Parts shown in **bold face (darker)** type are more likely to need replacement after extended periods of normal use.

They are readily available from most Warren Rupp distributors. The pump owner may prefer to maintain a limited inventory of these parts in his own stock to reduce repair downtime to a minimum.

IMPORTANT: When ordering repair parts always furnish pump model number, serial number and type number.

ITEM NO.	PART NUMBER	DESCRIPTION	TOTAL RQD.
34	560-020-360	O-Ring	6
35	031-012-000	Sleeve & Spool Set	1
36	132-014-358	Bumper, Spool	2
37	360-010-425	Gasket, End Cap	2
38	165-011-332	Cap, End	2
39	170-032-115	Capscrew, Hex Hd.	8
40	170-045-115	Capscrew, Hex Hd.	4
41	095-047-332	Body Valve	1
42	807-044-115	Stud	8
43	406-003-000	Knob, Locking	8
45	405-007-115	Handle (fits on P/N 196-041-xxx)	
46	132-022-360	Bumper	2
47	612-197-111	Plate, Outer Diaphragm	2
	612-197-113	Plate, Outer Diaphragm	2

Repair Parts Not Shown:

893-057-332	Valve, Angle ³	1
538-025-335	Nipple, Pipe ³	1
031-019-332	Valve Body Ass'y (consists of items: 34-39, 41)	1
535-015-000	Name Plate	1
705-002-000	Drive Screw	4

¹ Available in kit form. Order P/N 031-055-000 which also includes items 9, 31, 33, 46.

² Items 26 thru 30 may be ordered individually, or as a kit: #476-051-000. It is recommended that four kits (required for each pump) be purchased and replaced at the same time.

³ These items are available in Kit Form Only. They are no longer included on standard units. Order as Angle Valve Kit #475-115-000.

Repair Parts shown in **bold face (darker)** type are more likely to need replacement after extended periods of normal use.

They are readily available from most Warren Rupp distributors. The pump owner may prefer to maintain a limited inventory of these parts in his own stock to reduce repair downtime to a minimum.

IMPORTANT: When ordering repair parts always furnish pump model number, serial number and type number.

MATERIAL CODES

The Last 3 Digits of Part Number

000...	Assembly, sub-assembly; and some purchased items
010...	Cast Iron
015...	Ductile Iron
025...	Music Wire
080...	Carbon Steel, AISI B-1112
110...	Alloy Type 316 Stainless Steel
112...	Alloy "C"
114...	303 Stainless Steel
115...	301/302/304 Stainless Steel
120...	416 Stainless Steel (Wrought Martensitic)
148...	Hardcoat Anodized Aluminum
150...	6061-T6 Aluminum
151...	6063-T6 Aluminum
154...	Almag 35 Aluminum
155 or 156...	356-T6 Aluminum
157...	Die Cast Aluminum Alloy #380
159...	Anodized Aluminum
162...	Brass, Yellow, Screw Machine Stock
170...	Bronze, Bearing Type, Oil Impregnated
180...	Copper Alloy
330...	Plated Steel
331...	Chrome Plated Steel
332...	Electroless Nickel Plated
335...	Galvanized Steel
354...	Injection Molded #203-40 Santoprene — Duro 40D +/-5; Color: RED
356...	Hytrel
357...	Rupplon (Urethane Rubber)
360...	Buna-N Rubber. Color coded: RED
363...	Viton (Fluorel). Color coded: YELLOW
364...	E.P.D.M. Rubber. Color coded: BLUE
365...	Neoprene Rubber. Color coded: GREEN
366...	Food Grade Nitrile. Color coded: WHITE
375...	Fluorinated Nitrile
405...	Cellulose Fibre
408...	Cork and Neoprene
425...	Compressed Fibre
440...	Vegetable Fibre
500...	Delrin 500
501...	Delrin 570
520...	Injection Molded PVDF, Natural Color, Food Grade/USDA Acceptable
540...	Nylon
550...	Polyethylene
551...	Polypropylene
555...	PVC (Polyvinyl Chloride)
580...	Ryton
600...	Teflon (virgin material) Tetrafluoroethylene (TFE)
603...	Blue Gylon
604...	Teflon — Diaphragm
610...	Encapsulated Silicon
611...	Teflon Encapsulated Viton

Delrin, Teflon, Hytrel, and Viton are registered tradenames of E.I. DuPont. Gylon is a registered tradename of Garlock, Inc. Rupplon and SandPIPER are registered tradenames of Warren Rupp, Inc. Ryton is a registered tradename of Phillips Chemical Company. Loctite is a registered tradename of Loctite Corporation.

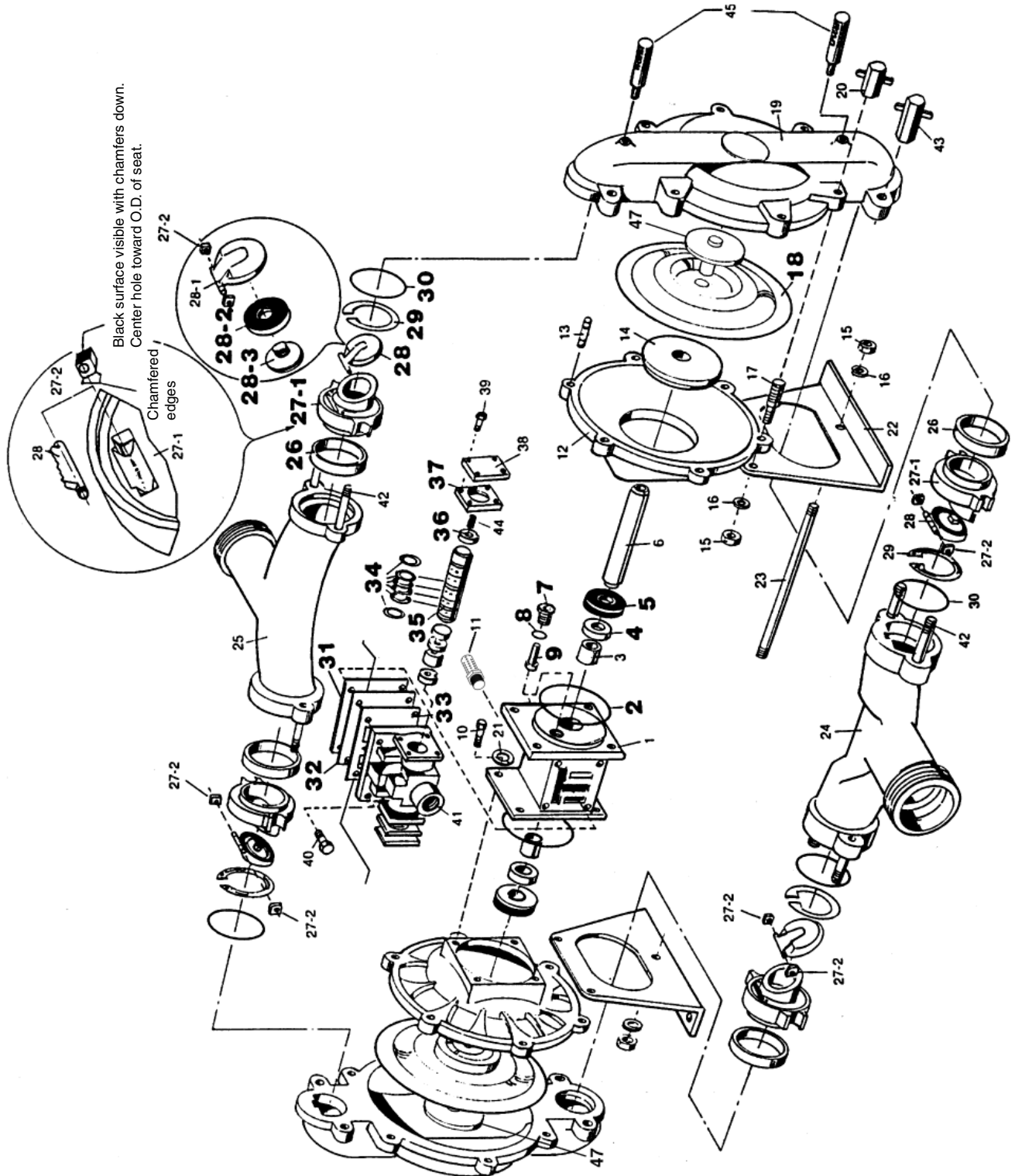

©1999 Warren Rupp, Inc. All rights reserved.
 ©Warren Rupp, SandPIPER is a registered tradename of Warren Rupp, Inc.
 Printed in USA