

OPERATION – ASSEMBLY INSTRUCTIONS AND PARTS LIST FOR “L8” DRIVE END (FRAME SIZES 1L8, 2L8, 3L8, 3M6, 3P4, 6P4, 9P4)

GENERAL

The Moyno® Pump is one of the most versatile pumps available. It has been proven in thousands of applications over the past 40 years. It is backed by the experience gained over the years, both in application and manufacturing know-how.

The Moyno progressing cavity pump is a single-screw rotary pump. The pumping action is created by the single helical rotor rolling eccentrically in the double threaded helix of the stator. In its revolution, the rotor forms in conjunction with the stator a series of sealed cavities 180 degrees apart. As the rotor turns, the cavities progress from the suction to the discharge. As one cavity diminishes, the opposing cavity is increasing at exactly the same rate. Thus, the sum of the two discharges is a constant volume. The result is a pulsation-less positive displacement flow with no valves.

NAMEPLATE DATA

The Moyno Pump nameplate, located on the bearing housing, carries the serial number, frame size, and type designation. All are extremely important and must be used when ordering spare parts.

Record the nameplate data of your pump in the spaces provided in the heading of Page 3.

Moyno Pumps are identified by Frame and Type. Pump Frame is essentially an indication of size. It consists of a number, a letter, and a number (i.e. 2L8). The first number indicates the number of stages in the pumping elements. The letter indicates the model. The final number indicates the size of the rotor-stator pumping elements. A frame 2L8 pump, therefore, has two stages of size 8 pumping elements.

The “L” in the frame size indicates a standard relationship between the housing, bearings, and drive shaft and the size of the pumping elements. Many variations may be made by adapting smaller element sizes to a larger drive end size. This may be necessary due to the severity of a specific pumping application. In cases where the drive end (housing, bearings, and drive shaft) is one size larger than the element size normally used, the pump is referred to as an “M” frame pump (i.e. 3M6). If the drive end is two sizes larger than the element size, the pump is referred to as a “P” frame. Thus, a frame 3L8, 3M6 and 3P4 would all use a common drive end.

Type designation is a series of letters which identify the “Materials of Construction” in

component groups of parts. The usual type designation will consist of three letters.

The first letter identifies the material of the suction housing casting or the body casting where the bearing housing is a part of the suction housing.

The second letter indicates the material used in the drive shaft, pins, connecting rod, rotor, and other minor metallic parts in contact with the material being pumped.

The third letter determines the material of the stator. It identifies only the stator material and not that of the tube in which the stator is placed.

A typical type designation such as CDQ would result in the following:

- C = Cast Iron Suction Housing
- D = Hardened Steel Internals including drive shaft, pins, connecting rod, rotor, and other minor metallic parts in contact with the material being pumped
- Q = Nitrile Synthetic Rubber Stator (70 durometer)

The following letters identify the actual materials that are used in standard construction:

- | | |
|---------------------------|-----------------------------------|
| B - EPDM | Q - Nitrile (70 durometer) |
| C - Cast Iron | R - Natural Rubber (55 durometer) |
| D - Hardened Steel | S - Stainless Steel, type #316 |
| F - Fluoroelastomer | T - Teflon (glass impregnated) |
| G - Stainless Steel, #416 | |

Also included on the nameplate is the three-character trim code designation. This only appears on pumps which have semi-standard or special construction. The first letter identifies sealing variations, the second character identifies internal variations, and the third letter identifies rotor variations.

On page 5 of this manual are variations available for modifying pumps to meet specialized pumping conditions. If the trim code of your pump is other than “AAA”, contact your nearest Moyno representative for clarification. Do not use any variation unless you have determined that it is compatible with your application.

Do not order by Reference Number. Use Part Number on page 3.

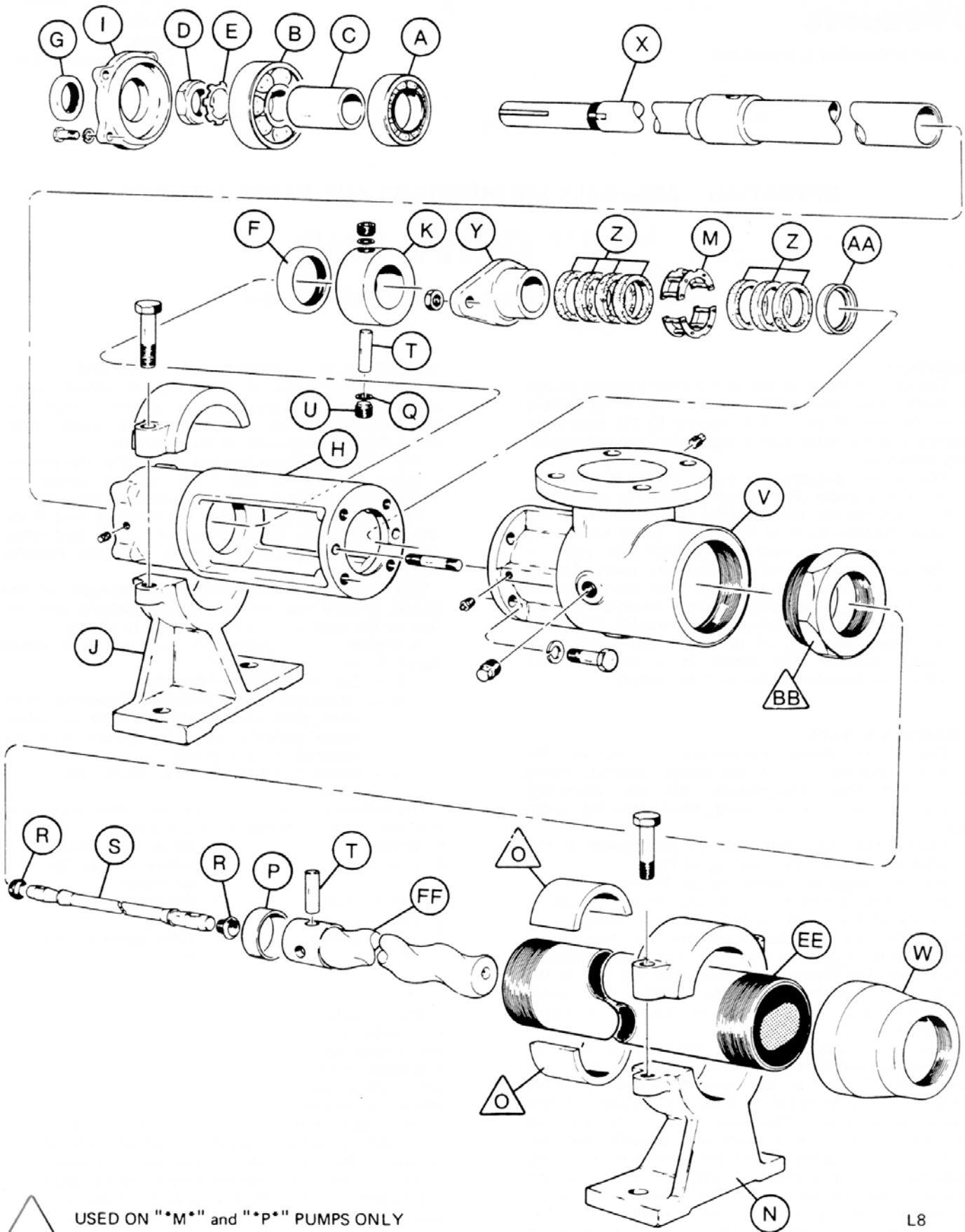

△ USED ON "M" and "P" PUMPS ONLY

NAMEPLATE DATA

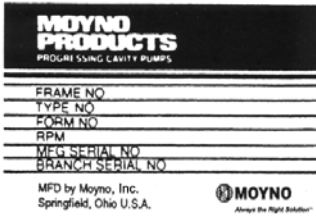

“L8” DRIVE END PARTS
TYPE DESIGNATIONS

Select type column corresponding to type designation at left.
Order by part number Refer to frame size to select proper rotor and stator.

REF. NO.	DESCRIPTION	CDQ CDR CDB CDF	CDD CDG CDT	CSQ CSR CSB CSF	CSD CSG CST	SSQ SSR SSB SSF	SSG SST
		Part No.	Part No.	Part No.	Part No.	Part No.	Part No.
A.	Ball Bearing (Radial)	A08291	A08291	A08291	A08291	A08291	A08291
B.	Ball Bearing (Thrust)	A08301	A08301	A08301	A08301	A08301	A08301
C.	Bearing Spacer	A08331	A08331	A08331	A08331	A08331	A08331
D.	Bearing Lock Nut	A08581	A08581	A08581	A08581	A08581	A08581
E.	Bearing Lock Washer	A08591	A08591	A08591	A08591	A08591	A08591
F.	Grease Seal (Radial)	A08611	A08611	A08611	A08611	A08611	A08611
G.	Grease Seal (Thrust)	A08621	A08621	A08621	A08621	A08621	A08621
	Bearing Kit**	K08291	K08291	K08291	K08291	K08291	K08291
H.	Bearing Housing	A08051	A08051	A08051	A08051	A08051	A08051
I.	Bearing Cover Plate	A08341	A08341	A08341	A08341	A08341	A08341
J.	Pump Support	A08371	A08371	A08371	A08371	A08371	A08371
K.	Shaft Collar	A08491	A08491	A08491	A08491	A08491	A08491
M.	Lantern Ring	A08571	A08571	A08571	A08571	A08571	A08571
N.	Stator Support 1 L8, 2L8, 3L8 3M6, 3P4, 6P4, 9P4	A08381 A08382	A08381 A08382	A08381 A08382	A08381 A08382	A08381 A08382	A08381 A08382
O.	Support Bushing 3P4 9P4	A08711 A06712	A06712 -----	A08711 A06712	A06712 -----	A08711 A06712	A06712 -----
P.	Pin Retainer	A08501	A08501	A08501	A08501	A08501	A08501
Q.	Retaining Screw Washer	A08731	A08731	A08731	A08731	A08731	A08731
R.	Connecting Rod Washer	A08531	A08531	A08531	A08531	A08531	A08531
S.	Connecting Rod	B0825D	B0825D	B0825S	B0825S	B0825S	B0825S
T.	Rotor Pin or Shaft Pin	B0845D	B0845D	B0845S	B0845S	B0845S	B0845S
U.	Drive Pin Retaining Screw Connecting Rod Kit***	B0854D K0825D	B0854D K0825D	B0854S K0825S	B0854S K0825S	B0854S K0825S	B0854S K0825S
V.	Suction Housing	B08021	B08021	B08021	B08021	B08026	B08026
W.	Reducer						
	1L8, 2L8, 3L8 only	B08091	B08091	B08091	B08091	B08096	B08096
	3M6	B06091	B06091	B06091	B06091	B06096	B06096
	3P4	B04091	B04092	B04091	B04092	B04096	B04097
	6P4	B06091	B06091	B06091	B06091	B06096	B06096
	9P4	B08092	-----	-----	-----	B08097	-----
X.	Drive Shaft +	B08261	B08261	B08266	B08266	B08266	B08266
Y.	Packing Gland	B0841D	B0841D	B0841S	B0841S	B0841S	B0841S
Z.	Packing +	B08421	B08421	B08425	B08425	B08425	B08425
AA.	Packing Washer	B0865D	B0865D	B0865S	B0865S	B0865S	B0865S
BB.	Adapter Bushing						
	3M6, 6P4	B08511	B08511	B08511	B08511	B08516	B08516
	3P4 Only	B08512	B08513	B08512	B08513	B08517	B08518
	9P4 Only	B08513	-----	B08513	-----	B08518	-----
EE.	Stator Frame 1L8	C4108*	C4108*	C4108*	C4108*	C5108*	C5108*
	Frame 2L8	C4208*	C4208*	C4208*	C4208*	C5208*	C5208*
	Frame 3M6	C4306*	C4306*	C4306*	C4306*	C5306*	C5306*
	Frame 3P4	C4304*	C4304*	C4304*	C4304*	C5304*	C5304*
	Frame 6P4	C4604*	C4604*	C4604*	C4604*	C5604*	C5604*
	Frame 9P4	C4904*	-----	C4904*	-----	C5904*	-----
FF.	Rotors Frame 1L8 +	C71081	C71081	C81081	C81081	C81081	C81081
	Frame 2L8 +	C72081	C72081	C82081	C82081	C82081	C82081
	Frame 3L8 +	C73081	C73081	C83081	C83081	C83081	C83081
	Frame 3M6 +	M73061	M73061	M83061	M83061	M83061	M83061
	Frame 3P4 +	P73041	P73041	P83041	P83041	P83041	P83041
	Frame 6P4 +	P76041	P76041	P86041	P86041	P86041	P86041
	Frame 9P4 +	P79041	-----	P89041	-----	P89041	-----

* ADD THIRD LETTER OF TYPE DESIGNATION TO COMPLETE PART NUMBER
EX: TYPE CDQ PUMP – ADD Q TO BASIC NUMBER OF STATOR

** Bearing Kit includes Items A thru G *** Connecting Rod Kit includes items Q thru U + see pages 5 - 6 for variations

INSTRUCTIONS FOR DISASSEMBLY AND ASSEMBLY

Frames 1L8, 2L8, 3L8, 3M6, 3P4, 6P4, 9P4

Disassembly Procedure

1. Disconnect the power source.
2. Close the suction and discharge valves to isolate the pump from the line.
3. Turn off flush water to packing or rotary seal if used.
4. Remove drain plug in suction housing to drain away any fluid remaining in pump.
5. Place a support block under suction housing in area of drain plug. Wooden blocks are sufficient. The purpose is to prevent undue stress on pump support when pump is disassembled.
6. Disconnect piping from stator end of pump.
7. **Stator Removal** - With pipe wrench or strap wrench remove discharge reducer (W). Remove cap of stator support and with strap wrench or pipe wrench, unscrew the stator (EE) from the suction housing. Pull Stator off the rotor.
8. **Rotor Removal** - The rotor (FF) is removed with the connecting rod (S) and rotor pin (T) as a unit. Removal of the unit is accomplished by removing the two drive pin retaining screws (U) located in the shaft collar (K). This step reveals the shaft drive pin (T), which is removed by driving the pin from the drive shaft (X) with a small punch or drift pin. Slide the shaft collar toward the packing gland (Y) and remove the retaining screw washers (Q) from each side of the drive shaft. The rotor and connecting rod can now be removed by pulling them from the pump. To disassemble, clamp the connecting rod (S) by its mid-section in a vise and, with a drift pin, drive the pin retainer (P) from the head of the rotor. The rotor pin (T) can now be removed from the rotor freeing the connecting rod. Remove the connecting rod washers (R) if present.
9. To remove packing (Z), remove nuts holding packing gland (Y). Slip packing gland from studs, remove packing rings, lantern ring (M), and remaining packing rings. Packing rings can be removed with a standard packing puller. Note: If step 10 is to be performed, it should precede step 9 as packing can then be removed by freeing packing gland and driving packing, lantern ring, and packing washer (AA) from housing using a small rod. Rod should enter where stator screws into suction housing. Place rod on packing washer and tap. Entire set should easily exit from opposite end of stuffing box.
10. **Drive Shaft & Bearing Removal** - With rotor removed it is now possible to remove the drive shaft and bearings as a sub-assembly. Remove the four cap screws holding the bearing cover plate (I) and slip from shaft. Insert a bar or rod into the hollow end of drive shaft (X) where it enters the suction cavity. By tapping on the rod the entire assembly will be forced from the bearing housing.

To disassemble, remove bearing lock nut (D) and bearing lock washer (E). Using an arbor press remove radial bearing (A), bearing spacer (C), and thrust bearing (B). Apply pressure to inner race only. When replacing drive shaft and/or bearings, it is recommended that both grease seals be replaced. Grease seals are pressed into the bearing housing and bearing cover plate.

Assembly Procedure

Moyno pumps are reassembled in the reverse order of disassembly with special notes as outlined below:

1. Always replace all old washers, "O" rings and packing. We also recommend replacing grease seals when new bearings are installed.
2. **Bearing Shaft Assembly** - When installing new bearings, make sure that they are seated against the shoulder on the shaft. Replace bearing lock washer and bearing lock nut. Tighten bearing lock nut securely. Bend tab down onto lock nut to prevent loosening of nut. Make sure that the shaft collar, packing gland, and packing washer are installed on the drive shaft as the hollow end emerges in the bearing housing and approaches the stuffing box area. When replacing the bearing cover plate, tighten all cap screws evenly to prevent damage to the bearing cover plate and thrust grease seal.

Do not over-lubricate bearings. (See Maintenance)
3. When installing the connecting rod, make sure that the hole in the rod is aligned with the holes in the drive shaft and shaft collar **before** inserting the pin. Always use retaining screw washers and make sure that the hollowed end of the retaining screw fits over the end of the shaft pin to ensure a tight fit. Retaining screws must seat on retaining screw washers and **not** on pin.
4. When replacing packing, insert three rings on the shaft, the lantern ring, and then four more rings. This will allow the lantern ring to line up with the grease fitting on the stuffing box. **Make sure you stagger the ends of the packing rings.** When installing the new packing, you may find that all but one ring will go on the drive shaft. When the pump has run for a short time and the new packing is compressed, this final ring can be installed.
5. When installing the stator on the rotor, it is best to lubricate the rotor with water (or a lubricant compatible with the rubber in the stator) to allow the stator to slip on easier. (Grease or oil is not compatible with type "R" or "B" stators.) When replacing the stator, always tighten it with the pipe wrench on the end of the stator nearest the suction housing. This will prevent it from binding and damaging the threads. If your stator has a stainless steel sleeve, use a teflon tape or similar material on the threads before replacing -- on all stators with a carbon steel sleeve, use pipe dope.

- 6. Caution: Dry operation is harmful to the pump. Always fill the pump with fluid to be handled prior to start up. Check any valves in discharge line to determine that no restrictions exist.**

MAINTENANCE

The Moyno pump has been designed for a minimum of maintenance, the extent of which is routine lubrication and adjustment of packing and infrequent lubrication of the bearings. The pump is one of the easiest to work on in that the main elements are very accessible and require few tools to disassemble.

Packing

The Moyno pump is normally furnished with die formed packing. The packing may be either grease lubricated through a grease fitting in the stuffing box or have plumbing connected to the housing to allow a water flush. (See Water Flush of Packing)

Packing gland adjusting nuts should be evenly adjusted so they are little more than finger tight. Over-tightening of the packing gland may result in premature packing failure and possible damage to the shaft and gland. When the packing is new, frequent minor adjustments are recommended for the first few hours of operation in order to compress and seat the packing. Greasing the packing often but with limited quantities of grease is the best practice. This can be done through a grease fitting which leads to a lantern ring in the mid-section of the packing. Do not use a one-piece spiral wrap of packing.

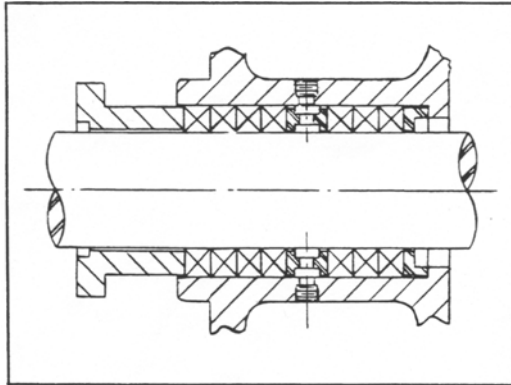

Cross section of stuffing box

Water Flush of Packing

When the material being pumped is abrasive in nature, it may be advantageous to flush the packing to prevent leakage under packing and excessive shaft wear.

Clean water can be injected through a 1/8" NPT tapped hole that normally houses the grease fitting for lubricating the packing. The water can be permitted to leak axially along the shaft in either direction or can be removed from the second tapped hole in the stuffing box. In both cases, the discharge from the stuffing box should be throttled slightly to maintain 10-15 PSI higher pressure in the stuffing box than is present in the suction housing.

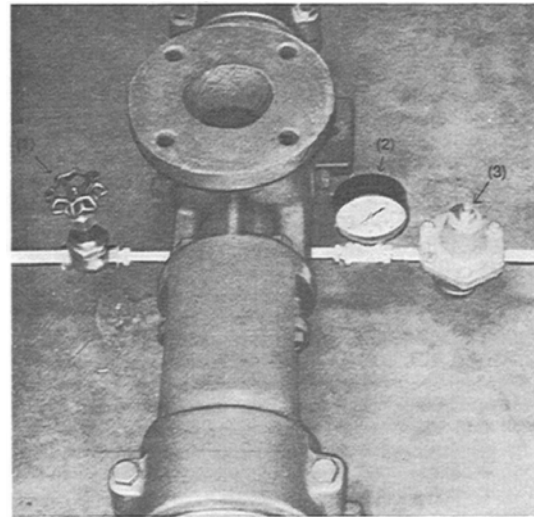

Typical water Flush to packing

This is a basic arrangement, other variations can be used.

(1) Throttling Valve (2) Pressure Gauge (3) Pressure Regulating Valve

This is a basic arrangement, other variations can be used.
(1) Throttling Valve (2) Pressure Gauge (3) Pressure Regulating Valve

Bearings

The Moyno pump is equipped with ball bearings in the drive end size L2 through L10. The bearings are lubricated at the factory and do not need additional lubrication for at least 1500 hours of normal operation.

When relubricating the bearings, the bearing-shaft assembly should be removed (See Disassembly instructions) and cleaned of old grease. Add only enough grease to fill the area between the bearings 1/3 full. Add a few drops of oil to bearing seals before reassembling. It is normal for bearings to run warm to the touch for the first few hours of operation.

Any type of Ep Lithium soap base grease is satisfactory for bearing lubrication. The use of Sodium or Calcium base grease is not recommended.

The following is a partial listing of approved bearing lubricants:

Dow Corning	DC 33
Keystone Lubricating Co.	Keystone #89
Texaco	Regal AFB2
Shell Oil Co.	Cyprina #3
Humble Oil & Refining Co.	Beacon 325
American Oil Co.	Supermil Grease #A72832
Mobil	EP1
Shell Oil Co.	Alvania #2

VARIATIONS OF STANDARD PARTS

ROTORS identified on parts listing are standard size with hard-chrome plated surface. Other variations of rotor size and finish may be ordered by selecting the standard rotor part number and changing the last digit of the rotor number as follows:

- 2 = Standard size, non-plated
- 3 = Undersize, chrome-plated
- 4 = Undersize, non-plated
- 5 = Oversize, chrome-plated

Do not change rotor sizes without consulting your local Moyno Sales Office. These variations are used for certain specialized pumping conditions only.

PACKING VARIATIONS listed are common to most type designations. Others may be specified by changing the last digit to the following:

- 1 = Standard on all type CDQ pumps
- 3 = Standard on all type CDR & SSR pumps
- 5 = Standard on all type SSQ pumps
- 7 = Optional--Solid Braided Teflon
- 8 = Optional--Teflon impregnated white asbestos

DRIVE SHAFTS shown have hard-chrome plating on the packing wear area. If non-plated drive shafts are required, select the standard part number and change the last digit to next higher number.

Example: B08261 to B08262.

L8 STANDARD HARDWARE

ITEM	SIZE	# REQ.
Bearing Cover Plate	1L X 1/2 D-13	4
Screw		
Lock Washer		4
Suction Housing Bolt	3 1/4L X 1/2 D-13	4
Lock Washer		4
Stator & Pump	2L X 5/8 D-11	4
Support Screw		
Packing Gland Stud	4 L 1/2 D-13	2
Nut	1/2 D-13	2
Suction Housing	1/2 D	3
Drain Plug		
Drain Plug on	1/8 D	1
Stuffing Box		
Grease Fitting on	1/8 D	1
Stuffing Box		
Pipe Plug on Bearing	1/8 D	2
Housing		
Hex Key	9/16	1

RECOMMENDED SPARE PARTS

The Moyno pump has been designed and built with all wearable parts replaceable. A recommended inventory of spare parts is dependent upon the application and importance of continued operation.

For the shortest possible downtime, we recommend the following parts be stocked:

- 1 - Rotor
- 1 - Stator
- 1 - Connecting Rod Kit

The above is only a suggested list. For further assistance in determining what you'll need for your application, contact your Moyno representative.