



II 2GD T5



SERVICE AND OPERATING MANUAL
Models MSB2 and MSB2-B
Ball Valve
Type 3
Mine/Construction Duty

Table of Contents

Principle of Operation 1

Installation and Start-Up..... 1

Air Supply 1

Air Inlet & Priming..... 2

Air Valve Lubrication 2

ESADS+Plus®: Externally Serviceable Air Distribution System 2

Air Exhaust 3

Between Uses 3

Check Valve Servicing..... 3

Diaphragm Servicing 3

Reassembly..... 4

Pilot Valve 4

Pilot Valve Actuator..... 4

Service Instructions: Troubleshooting 4-5

Warranty 5

Recycling..... 6

Important Safety Information 6

Installation 7

Material Codes 8

Composite Repair Parts List..... 9-10

Composite Repair Drawing..... 11



II 2GD T5



SERVICE AND OPERATING MANUAL

Models MSB2 and MSB2-B

Ball Valve

Type 3

Mine/Construction Duty

PRINCIPLE OF PUMP OPERATION

This ball valve pump is powered by compressed air and is a 1:1 pressure ratio design. It alternately pressurizes the inner side of one diaphragm chamber, while simultaneously exhausting the other inner chamber. This causes the diaphragms, which are connected by a common rod, to move endwise. Air pressure is applied over the entire surface of the diaphragm, while liquid is discharged from the opposite side. The diaphragm operates under a balanced condition during the discharge stroke, which allows the unit to be operated at discharge heads over 200 feet (61 meters) of water head.

Since the diaphragms are connected by a common rod, secured by plates to the center of the diaphragms, one diaphragm performs the discharge stroke, while the other is pulled to perform the suction stroke in the opposite chamber.

For maximum diaphragm life, keep the pump as close to the liquid being pumped as possible. Positive suction head in excess of 10 feet of liquid (3.048 meters) may require a back pressure regulating device. This will maximize diaphragm life.

Alternate pressuring and exhausting of the diaphragm chamber is performed by means of an externally mounted, pilot operated, four-way spool type air distribution valve. When the spool shifts to one end of the valve body, inlet air pressure is applied to one diaphragm chamber and the other diaphragm chamber exhausts. When the spool shifts to the opposite end of the valve body, the porting of chambers is reversed. The air distribution valve spool is moved by an internal pilot valve which alternately pressurizes one side of the air distribution valve spool, while exhausting the other side. The pilot valve is shifted at each end of the diaphragm stroke by the diaphragm plate coming in contact with the end of the pilot spool. This pushes it into position for shifting of the air distribution valve.

The chambers are manifolded together with a suction and discharge flap-type check valve for each chamber, maintaining flow in one direction through the pump.

INSTALLATION & START-UP

Locate the pump as close to the product being pumped as possible, keeping suction line length and number of fittings to a minimum. Do not reduce line size.

For installations of rigid piping, short flexible sections of hose should be installed between pump and piping. This reduces vibration and strain to the piping system. A Warren Rupp Tranquilizer® surge suppressor is recommended to further reduce pulsation in flow.

This pump was tested at the factory prior to shipment and is ready for operation. It is completely self-priming from a dry start for suction lifts of 10 feet (3.05 meters) or less. For suction lifts exceeding 20 feet of liquid, fill the chambers with liquid prior to priming.

AIR SUPPLY

Air supply pressures cannot exceed 125 psi (8.61 bar). Connect the pump air inlet to an air supply of sufficient capacity and pressure required for desired performance. When the air line is solid piping, use a short length of flexible hose [not less than 3/4" (19mm) in diameter] between pump and piping to eliminate strain to pipes.

AIR INLET & PRIMING

For start-up, open an air valve approximately 1/2" to 3/4" turn. After the unit primes, an air valve can be opened to increase flow as desired. If opening the valve increases cycling rate, but does not increase flow rate, cavitation has occurred, and the valve should be closed slightly.

For the most efficient use of compressed air and the longest diaphragm life, throttle the air inlet to the lowest cycling rate that does not reduce flow.

A NOTE ABOUT AIR VALVE LUBRICATION

The Sandpiper pump's pilot valve and main air valve assemblies are designed to operate WITHOUT lubrication. This is the preferred mode of operation. There may be instances of personal preference, or poor quality air supplies when lubrication of the compressed air supply is required. The pump air system will operate with properly lubricated compressed air supplies. Proper lubrication of the compressed air supply would entail the use of an air line lubricator (available from Warren Rupp) set to deliver one drop of 10 wt., non-detergent oil for every 20 SCFM of air the pump consumed at its point of operation. Consult the pump's published Performance Curve to determine this.

It is important to remember to inspect the sleeve and spool set routinely. It should move back and forth freely. This is most important when the air supply is lubricated. If a lubricator is used, oil accumulation will, over time, collect any debris from the compressed air. This can prevent the pump from operating properly.

Water in the compressed air supply can create problems such as icing or freezing of the exhaust air causing the pump to cycle erratically, or stop operating. This can be addressed by using a point of use air dryer to supplement a plant's air drying equipment. This device will remove excess water from the compressed air supply and alleviate the icing or freezing problem.

ESADS: EXTERNALLY SERVICEABLE AIR DISTRIBUTION SYSTEM

Please refer to the exploded view drawing and parts list in the Service Manual supplied with your pump. If you need replacement or additional copies, contact your local Warren Rupp Distributor, or the Warren Rupp factory Literature Department at the number shown below. To receive the correct manual, you must specify the MODEL and TYPE information found on the name plate of the pump.

MODELS WITH 1" SUCTION/DISCHARGE OR LARGER, AND METAL CENTER SECTIONS:

The main air valve sleeve and spool set is located in the valve body mounted on the pump with four hex head capscrews. The valve body assembly is removed from the pump by removing these four hex head capscrews.

With the valve body assembly off the pump, access to the sleeve and spool set is made by removing four hex head capscrews (each end) on the end caps of the valve body assembly. With the end caps removed, slide the spool back and forth in the sleeve. The spool is closely sized to the sleeve and must move freely to allow for proper pump operation. An accumulation of oil, dirt or other contaminants from the pump's air supply, or from a failed diaphragm, may prevent the spool from moving freely. This can cause the spool to stick in a position that prevents the pump from operating. If this is the case, the sleeve and spool set should be removed from the valve body for cleaning and further inspection.

Remove the spool from the sleeve. Using an arbor press or bench vise (with an improvised mandrel), press the sleeve from the valve body. Take care not to damage the sleeve. At this point, inspect the o-rings on the sleeve for nicks, tears or abrasions. Damage of this sort could happen during assembly or servicing. A sheared or cut o-ring can allow the pump's compressed air supply to leak or bypass within the air valve assembly, causing the pump to leak compressed air from the pump air exhaust or not cycle properly. This is most noticeable at pump dead head or high discharge pressure conditions. Replace any of these o-rings as required or set up a routine, preventive maintenance schedule to do so on a regular basis. This practice should include cleaning the spool and sleeve components with a safety solvent or equivalent, inspecting for signs of wear or damage, and replacing worn components.

To re-install the sleeve and spool set, lightly lubricate the o-rings on the sleeve with an o-ring assembly lubricant or lightweight oil (such as 10 wt. air line lubricant). Re-install one end cap, gasket and bumper on the valve body. Using the arbor press or bench vise that was used in disassembly, carefully press the sleeve back into the valve body, without shearing the o-rings. You may have to clean the surfaces of the valve body where the end caps mount. Material may remain from the old gasket. Old material not cleaned from this area may cause air leakage after reassembly. Take care that the bumper stays in place allowing the sleeve to press in all the way. Reinstall the spool, opposite end cap, gasket and bumper on the valve body. After inspecting and cleaning the gasket surfaces on the valve body and intermediate, reinstall the valve body on the pump using new gaskets. Tighten the four hex head capscrews evenly and in an alternating cross pattern.

AIR EXHAUST

If a diaphragm fails, the pumped liquid or fumes can enter the air end of the pump, and be exhausted into the atmosphere. When pumping hazardous or toxic materials, pipe the exhaust to an appropriate area for safe disposition.

This pump can be submerged if materials of construction are compatible with the liquid. The air exhaust must be piped above the liquid level. Piping used for the air exhaust must not be smaller than 1" (2.54 cm). Reducing the pipe size will restrict air flow and reduce pump performance. When the product source is at a higher level than the pump (flooded suction), pipe the exhaust higher than the product source to prevent siphoning spills. (See page 7)

Freezing or icing-up of the air exhaust can occur under certain temperature and humidity conditions. Use of an air dryer unit should eliminate most icing problems.

BETWEEN USES

When used for materials that tend to settle out or transform to solid form, the pump should be completely flushed after each use, to prevent damage. Product remaining in the pump between uses could dry out or settle out. This could cause problems with valves and diaphragms at re-start. In freezing temperatures, the pump must be drained between uses in all cases.

CHECK VALVE SERVICING

Need for inspection or service is usually indicated by poor priming, unstable cycling, reduced performance or the pump's cycling, but not pumping.

Inspect the surfaces of both check valves and seats for wear or damage that could prevent proper sealing. If pump is to prime properly, valves must seat air tight.

DIAPHRAGM SERVICING

Remove the eight bolts (four each side) securing the manifold assemblies to the outer chambers. Remove the eight bolts securing the outer chamber to the inner chamber. Remove the diaphragm assembly (outer plate, diaphragm, inner plate) by turning the assembly counterclockwise using a 16/16" (2.38 cm) wrench on the outer plate lugs. To disassemble the diaphragm assemblies, secure in a vise and turn the outer plate counterclockwise using the 16/16" wrench.

Procedures for reassembling the diaphragms are the reverse of the above. The diaphragms must be installed with their natural bulge to the outside, toward the outer diaphragm plate. Install the inner plate with the flat face against the diaphragm.

After all components are in position in a vise and hand tight, tighten with a wrench to approximately 40 ft. lbs. (54.23 Newton meters) torque. After both diaphragm assemblies have been assembled, thread one assembly into the shaft (hold the shaft near the middle in a vise with soft jaws, to protect the finish). Install this sub assembly into the pump and secure by placing the outer chamber on the end with the diaphragm. This holds the assembly in place while the opposite side is installed. Torque the last diaphragm assembly to 30 ft. lbs. (40.67 Newton meters). This final torquing will lock the diaphragm assemblies together. Place the remaining outer chamber on the open end and loosely tighten the bolts. Replace the manifold assemblies to square the flanges before final tightening of the remaining bolts. the diaphragm assemblies together. Place the remaining outer chamber on the open end and loosely tighten the bolts. Replace the manifold assemblies to square the flanges before final tightening of the remaining bolts.

REASSEMBLY

All procedures for reassembling the pump are the reverse of the previous instructions with further instructions as shown:

1. The diaphragm assemblies are to be installed with the natural bulge outward or toward the head of the center screw. Make sure both plates are installed with outer radii against the diaphragm. After all components are in position in a vise and hand tight, set a torque wrench for 480 inch pounds (40 ft. pounds) (54.23 Newton meters) using a 1 1/16 (27mm) wrench or six pointed socket. After each diaphragm sub assembly has been completed, thread one assembly into the shaft (held near the middle in a vise having soft jaws to protect the finish) making sure the stainless steel washer is in place on the capscrew.

Make sure 1/4"-20 mounting screw has been removed and that the bumper (Item #19 on drawing) is in place in the shaft.

Install this sub assembly into the pump and secure by placing the outer chamber housing and capscrews on the end with the diaphragm. This will hold the assembly in place while the opposite side is installed. Make sure the last diaphragm assembly is torqued to 30 ft. lbs. (40.67 Newton meters) before placing the outer diaphragm over the capscrews. If the holes in the diaphragm flange do not line up with the holes in the chamber flange, turn the diaphragm assembly in the direction of tightening to align the holes so that the capscrews can be inserted. This final torquing of the last diaphragm assembly will lock the two diaphragm assemblies together. Place remaining outer chamber on the open end and tighten down the securing fasteners gradually and evenly on both sides.

PILOT VALVE

The pilot valve assembly is accessed by removing the main air distribution valve body from the pump and lifting the pilot valve body out of the intermediate housing.

Most problems with the pilot valve can be corrected by replacing the o-rings. Always grease the spool prior to inserting it into the sleeve. If the sleeve is removed from the body, reinsertion must be at the chamfered side. Grease the o-rings to slide the sleeve into the valve body. Securely insert the retaining ring around the sleeve. When reinserting the pilot valve, push both plungers (located inside the intermediate bracket) out of the path of the pilot valve spool ends to avoid damage.

PILOT VALVE ACTUATOR

Bushings for the pilot valve actuators are threaded into the intermediate bracket from the outside. The plunger may be removed for inspection or replacement. First remove the air distribution valve body and the pilot valve body from the pump. The plungers can be located by looking into the intermediate. It may be necessary to use a fine piece of wire to pull them out. The bushing can be turned out through the inner chamber by removing the outer chamber assembly. Replace the bushings if pins have bent.

TROUBLESHOOTING

PROBLEM: Pump cycles but will not pump. (Note: higher suction lifts require faster cycling speed for priming.)

POSSIBLE CAUSES:

- A. Air leak in suction line.
- B. Excessive suction lift.
- C. Check valve not seating properly.
- D. Leakage at joint of suction manifold or elbow flange.
- E. Suction line or strainer plugged.
- F. Diaphragm ruptured.

PROBLEM: Pump will not cycle. (Note: Always disconnect air supply to relieve air pressure before disassembling any portion of pump.)

POSSIBLE CAUSES:

- A. Discharge hose or line plugged, or discharge head requirement greater than air supply pressure. (Disconnect discharge line to check.)
- B. Spool in air distribution valve not shifting. (Remove end cap and check spool — must slide freely.)
- C. Diaphragm ruptured. (Air will escape out discharge line in this case.)
- D. Blockage in diaphragm chamber preventing movement. (Shut off air supply and reopen after pressure is relieved.)

PROBLEM: Uneven discharge flow. (Indicates one chamber not operating properly.)

POSSIBLE CAUSES:

- A. Check valve not sealing properly in one chamber.
- B. Diaphragm failure in one chamber.
- C. Air leak at suction manifold joint or elbow flange one side.

For additional information, see the Warren Rupp Troubleshooting Guide.

WARRANTY:

This unit is guaranteed for a period of five years against defective material and workmanship.

Grounding The Pump

ONE EYELET IS FASTENED TO THE PUMP HARDWARE.

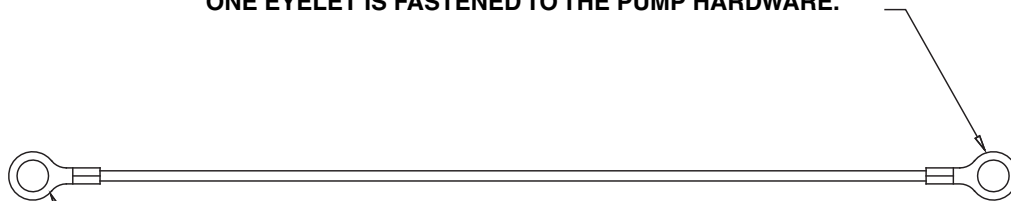

ONE EYELET IS INSTALLED TO A TRUE EARTH GROUND.
(REQUIRES A 5/16 OR 8MM MAXIMUM DIAMETER BOLT)

This 8 foot long (244 centimeters) Ground Strap, part number 920-025-000, can be ordered as a service item.

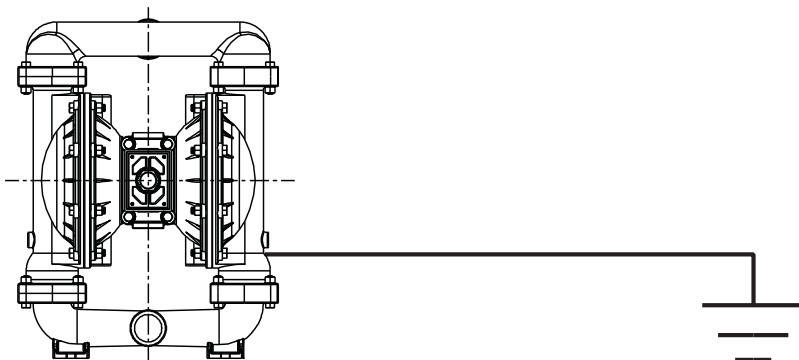

To reduce the risk of static electrical sparking, this pump must be grounded. Check the local electrical code for detailed grounding instruction and the type of equipment required.

	⚠ WARNING <i>Take action to prevent static sparking. Fire or explosion can result, especially when handling flammable liquids. The pump, piping, valves, containers or other miscellaneous equipment must be grounded.</i>
---------------------------------------------------------------------------------------	--------------------------------------------------------------------------------------------------------------------------------------------------------------------------------------------------------------------------------------

©2009 Warren Rupp, Inc. All rights reserved.

©Warren Rupp and SANDPIPER are registered tradenames of Warren Rupp, Inc.

Printed in U.S.A.

Recycling

Many components of SANDPIPER® Metallic AODD pumps are made of recyclable materials. We encourage pump users to recycle worn out parts and pumps whenever possible, after any hazardous pumped fluids are thoroughly flushed.



⚠ IMPORTANT

Read these safety warnings and instructions in this manual completely, before installation and start-up of the pump. It is the responsibility of the purchaser to retain this manual for reference. Failure to comply with the recommendations stated in this manual will damage the pump, and void factory warranty.



⚠ WARNING

Take action to prevent static sparking. Fire or explosion can result, especially when handling flammable liquids. The pump, piping, valves, containers or other miscellaneous equipment must be grounded. (See page 6).



⚠ WARNING

Before doing any maintenance on the pump, be certain all pressure is completely vented from the pump, suction, discharge, piping, and all other openings and connections. Be certain the air supply is locked out or made non-operational, so that it cannot be started while work is being done on the pump. Be certain that approved eye protection and protective clothing are worn all times in the vicinity of the pump. Failure to follow these recommendations may result in serious injury or death.



⚠ CAUTION

Before pump operation, inspect all gasketed fasteners for looseness caused by gasket creep. Retorque loose fasteners to prevent leakage. Follow recommended torques stated in this manual.



⚠ WARNING

In the event of diaphragm rupture, pumped material may enter the air end of the pump, and be discharged into the atmosphere. If pumping a product which is hazardous or toxic, the air exhaust must be piped to an appropriate area for safe disposition.



⚠ WARNING

POSSIBLE EXPLOSION HAZARD can result if 1, 1, 1-Trichloroethane, Methylene Chloride or other Halogenated Hydrocarbon solvents are used in pressurized fluid systems having Aluminum or Galvanized wetted parts. Death, serious bodily injury and/or property damage could result. Consult with the factory if you have questions concerning Halogenated Hydrocarbon solvents.



⚠ WARNING

Before maintenance or repair, shut off the compressed air line, bleed the pressure, and disconnect the air line from the pump. The discharge line may be pressurized and must be bled of its pressure.



⚠ WARNING

When used for toxic or aggressive fluids, the pump should always be flushed clean prior to disassembly.



⚠ WARNING

Airborne particles and loud noise hazards. Wear ear and eye protection.

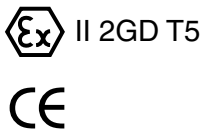

Pump complies with EN809 Pumping Directive and Directive 98/37/EC Safety of Machinery, and ATEX 100a Directive 94/9/EC Equipment for use in Potentially Explosive Environments. For documentation consult the manufacturer or visit: www.warrenrupp.com

PUMPING HAZARDOUS LIQUIDS

When a diaphragm fails, the pumped liquid or fumes enter the air end of the pump. Fumes are exhausted into the surrounding environment. When pumping hazardous or toxic materials, the exhaust air must be piped to an appropriate area for safe disposal. See illustration #1 at right.

This pump can be submerged if the pump materials of construction are compatible with the liquid being pumped. The air exhaust must be piped above the liquid level. See illustration #2 at right. Piping used for the air exhaust must not be smaller than 1" (2.54 cm) diameter. Reducing the pipe size will restrict air flow and reduce pump performance. When the pumped product source is at a higher level than the pump (flooded suction condition), pipe the exhaust higher than the product source to prevent siphoning spills. See illustration #3 at right.

CONVERTING THE PUMP FOR PIPING THE EXHAUST AIR

The following steps are necessary to convert the pump to pipe the exhaust air away from the pump.

The air distribution valve has 3/4" NPT threads for piped exhaust.

IMPORTANT INSTALLATION NOTE:

The manufacturer recommends installing a flexible conductive hose or connection between the pump and any rigid plumbing. This reduces stresses on the molded threads of the air exhaust port. Failure to do so may result in damage to the air distribution valve body.

Any piping or hose connected to the pump's air exhaust port must be conductive and physically supported. Failure to support these connections could also result in damage to the air distribution valve body.

CONVERTED EXHAUST ILLUSTRATION

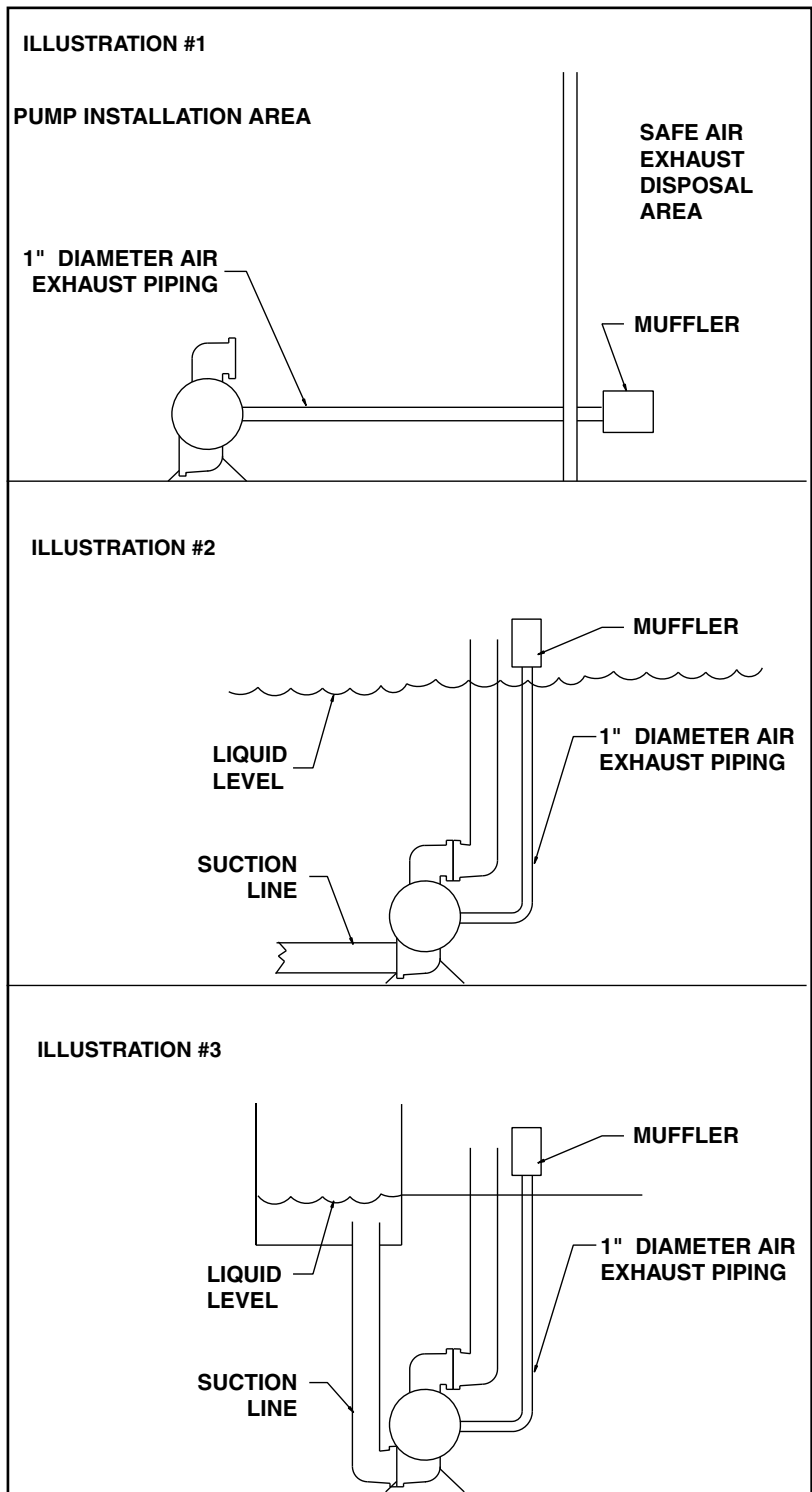

Material Codes

The Last 3 Digits of Part Number

000	Assembly, sub-assembly; and some purchased items	333	Carbon Steel, Electroless Nickel Plated	555	Polyvinyl Chloride
010	Cast Iron	335	Galvanized Steel	556	Black Vinyl
012	Powered Metal	336	Zinc Plated Yellow Brass	557	Conductive Polypropylene
015	Ductile Iron	337	Silver Plated Steel	558	Conductive HDPE
020	Ferritic Malleable Iron	340	Nickel Plated	559	Glass-Filled Conductive Polypropylene
025	Music Wire	342	Filled Nylon	570	Rulon II
080	Carbon Steel, AISI B-1112	353	Geolast; Color: Black	580	Ryton
100	Alloy 20	354	Injection Molded #203-40 Santoprene- Duro 40D +/-5; Color: RED	590	Valox
110	Alloy Type 316 Stainless Steel	355	Thermal Plastic	591	Nylatron G-S
111	Alloy Type 316 Stainless Steel (Electro Polished)	356	Hytrell	592	Nylatron NSB
112	Alloy C	357	Injection Molded Polyurethane	600	PTFE (virgin material) Tetrafluorocarbon (TFE)
113	Alloy Type 316 Stainless Steel (Hand Polished)	358	Urethane Rubber (Some Applications) (Compression Mold)	601	PTFE (Bronze and moly filled)
114	303 Stainless Steel			602	Filled PTFE
115	302/304 Stainless Steel	359	Urethane Rubber	603	Blue Gylon
117	440-C Stainless Steel (Martensitic)	360	Nitrile Rubber. Color coded: RED	604	PTFE
120	416 Stainless Steel (Wrought Martensitic)	361	FDA Accepted Nitrile	606	PTFE
123	410 Stainless Steel (Wrought Martensitic)	363	FKM (Fluorocarbon). Color coded: YELLOW	607	Envelon
148	Hardcoat Anodized Aluminum	364	E.P.D.M. Rubber. Color coded: BLUE	608	Conductive PTFE
149	2024-T4 Aluminum	365	Neoprene Rubber. Color coded: GREEN	610	PTFE Integral Silicon
150	6061-T6 Aluminum	366	Food Grade Nitrile	611	PTFE Integral FKM
151	6063-T6 Aluminum	368	Food Grade EPDM	632	Neoprene/Hytrel
152	2024-T4 Aluminum (2023-T351)	370	Butyl Rubber. Color coded: BROWN	633	FKM (Fluorocarbon)/PTFE
154	Almag 35 Aluminum	371	Philthane (Tuftane)	634	EPDM/PTFE
155	356-T6 Aluminum	374	Carboxylated Nitrile	635	Neoprene/PTFE
156	356-T6 Aluminum	375	Fluorinated Nitrile	637	PTFE, FKM (Fluorocarbon)/PTFE
157	Die Cast Aluminum Alloy #380	378	High Density Polypropylene	638	PTFE, Hytrel/PTFE
158	Aluminum Alloy SR-319	379	Conductive Nitrile	639	Nitrile/TFE
159	Anodized Aluminum	405	Cellulose Fibre	643	Santoprene/EPDM
162	Brass, Yellow, Screw Machine Stock	408	Cork and Neoprene	644	Santoprene/PTFE
165	Cast Bronze, 85-5-5-5	425	Compressed Fibre	650	Bonded Santoprene and PTFE
166	Bronze, SAE 660	426	Blue Gard	654	Santoprene Diaphragm, PTFE Overlay Balls and seals
170	Bronze, Bearing Type, Oil Impregnated	440	Vegetable Fibre	656	Santoprene Diaphragm and Check Balls/EPDM Seats
175	Die Cast Zinc	465	Fibre	661	EPDM/Santoprene
180	Copper Alloy	500	Delrin 500		
305	Carbon Steel, Black Epoxy Coated	501	Delrin 570		Delrin and Hytrel are registered tradenames of E.I. DuPont.
306	Carbon Steel, Black PTFE Coated	502	Conductive Acetal, ESD-800		Gylon is a registered tradename of Garlock, Inc.
307	Aluminum, Black Epoxy Coated	503	Conductive Acetal, Glass-Filled		Nylatron is a registered tradename of Polymer Corp.
308	Stainless Steel, Black PTFE Coated	505	Acrylic Resin Plastic		Santoprene is a registered tradename of Monsanto Corp.
309	Aluminum, Black PTFE Coated	506	Delrin 150		Rulon II is a registered tradename of Dixion Industries Corp.
310	PVDF Coated	520	Injection Molded PVDF Natural color		Ryton is a registered tradename of Phillips Chemical Co.
330	Zinc Plated Steel	521	Conductive PVDF		Valox is a registered tradename of General Electric Co.
331	Chrome Plated Steel	540	Nylon		Warren Rupp, SANDPIPER, Portapump, Tranquilizers and SludgeMaser are registered tradenames of Warren Rupp, Inc.
332	Aluminum, Electroless Nickel Plated	541	Nylon		
		542	Nylon		
		544	Nylon Injection Molded		
		550	Polyethylene		
		551	Glass Filled Polypropylene		
		552	Unfilled Polypropylene		
		553	Unfilled Polypropylene		



SERVICE AND OPERATING MANUAL
Models MSB2 and MSB2-B
Ball Valve
Type 3
Mine/Construction Duty

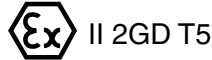

ITEM NO.	PART NUMBER	DESCRIPTION	TOTAL RQD.
1	070-006-170	Bearing, Sleeve	2
2	114-002-156	Bracket, Intermediate	1
3	720-004-360	Seal, U-Cup	2
4	135-016-162	Bushing, Threaded, w/O-Ring	
5	620-011-114	Plunger, Actuator	2
6	095-073-000	Pilot Valve Body Assembly	1
6-A	095-070-551	Valve Body	1
6-B	755-025-000	Sleeve (w/O-Ring)	1
6-C	560-033-360	O-Ring (Sleeve)	4
6-D	775-026-000	Spool (w/O-Ring)	1
6-E	560-023-360	O-Ring (Spool)	2
6-F	675-037-080	Retaining Ring	1
7	360-041-379	Gasket, Valve Body	1
8	560-001-360	O-Ring	2
9	095-043-156	Body, Valve	1
10	132-014-358	Bumper, Valve Spool	2
11	165-011-157	Cap, End	2
12	360-048-425	Gasket, Valve Body	1
13	360-010-425	Gasket, End Cap	2
14	560-020-360	O-Ring	6
15	031-012-000	Sleeve & Spool Set	1
16	170-032-330	Capscrew, Hex Head	8
17	170-045-330	Capscrew, Hex Head	4
18	132-002-360	Bumper, Diaphragm	2
19	196-001-157	Chamber, Inner	2
20	286-007-365	Diaphragm	2
	286-007-360	Diaphragm	2
	286-007-354	Diaphragm	2
21	560-022-360	O-Ring	2
22	685-007-120	Rod, Diaphragm	1
23	170-023-330	Capscrew, Hex Head	16
24	170-024-330	Capscrew, Hex Head	8
25	618-003-330	Plug, Pipe (SS & Alloy C Qty. 2)	4
26	900-006-330	Washer, Lock	8
27	612-215-330	Plate, Diaphragm	2
28	612-224-330	Plate, Outer	2
29	170.010.115	Capscrew	2
31	545-007-330	Nut, Hex	16
32	722-040-365	Seat, Valve	4
	722-040-360	Seat, Valve	4
	722-040-364	Seat, Valve	4

ITEM NO.	PART NUMBER	DESCRIPTION	TOTAL RQD.
33	050-017-365	Ball, Check Valve	4
	050-017-360	Ball, Check Valve	4
	050-017-354	Ball, Check Valve	4
34	518-032-156	Manifold, Suction (MSB2-B Only)	1
	518-032-156E	Manifold, Suction	1
35	518-033-156	Manifold, Discharge (NPT)	2
	518-033-156E	Manifold, Discharge	2
36	902-003-000	Stat-O-Seal	2
37	170-082-330	Capscrew, Hex Head	4
38	900-003-330	Washer, Lock	8
39	545-008-330	Nut, Hex (Not used on CI units)	8
41	196-047-156	Chamber, Outer	2
42	530-036-000	Muffler, Exhaust	1
48	800-012-156	Base, Strainer (MSB2-A)	1
49	518-044-156	Manifold, Suction (MSB2-A)	1
50	170-055-330	Capscrew, Hex Head (MSB2-A)	4
51	258-016-156	Cover, Suction (MSB2-A)	1
52	170-035-330	Capscrew, Hex Head (MSB2-A)	1
53	900-006-330	Washer, Lock (MSB2-A)	1
54	570-009-360	Pad, Wear	2
	570-009-365	Pad, Wear	2
55	115-161-080	Handle Bracket	2
56	115-162-080	Handle Bracket	2
57	405-012-330	Handle	2

Not Shown

031-019-156	Main Air Valve Assembly (Includes Items 9, 10, 11, 13, 14, 15, 16)	1
-------------	-----------------------------------------------------------------------	---

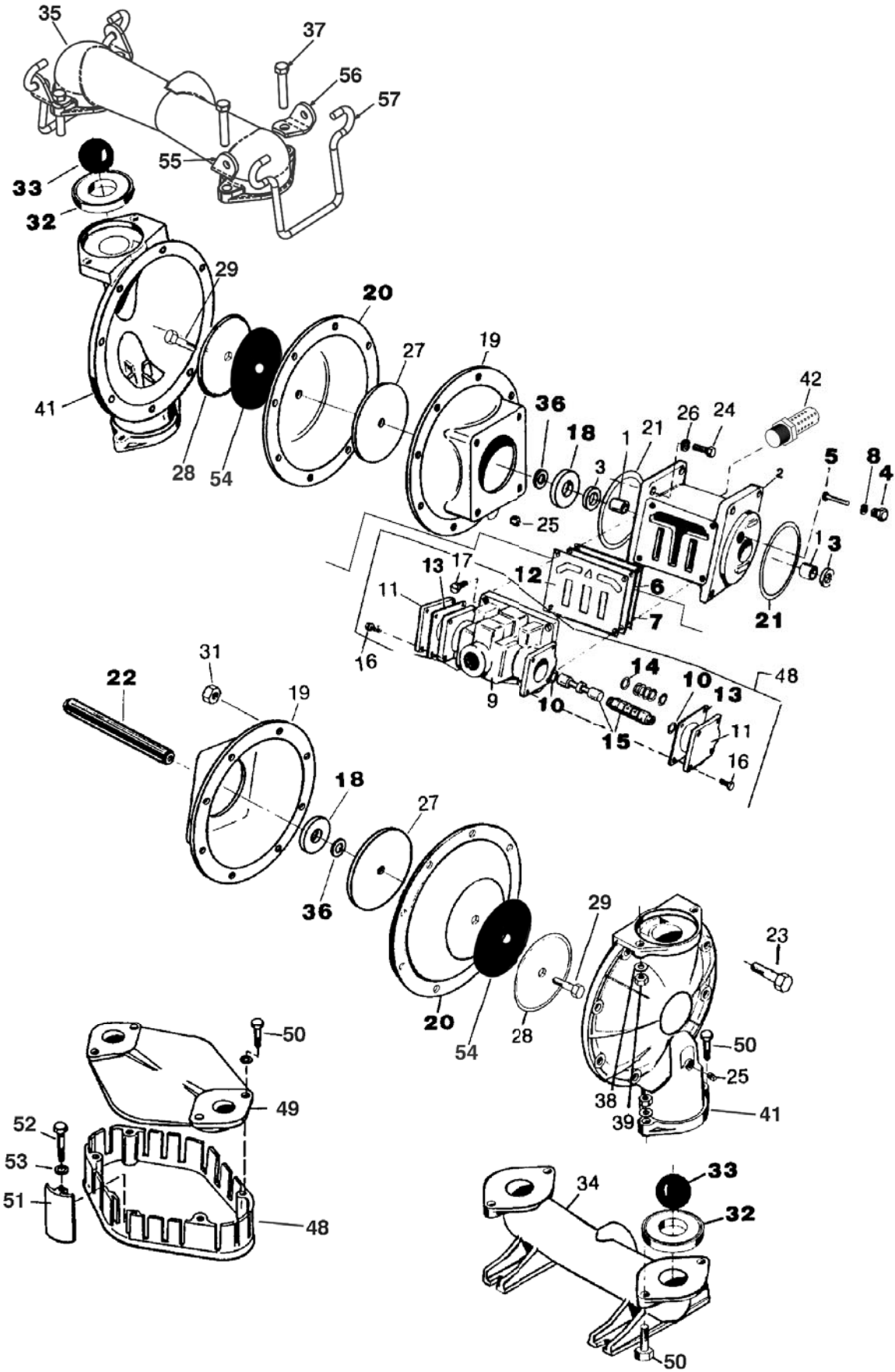

©2009 Warren Rupp, Inc. All rights reserved.
 © Warren Rupp, SANDPIPER is a registered trademark of Warren Rupp, Inc.
 Printed in U.S.A.