



Table of Contents

Principle of Operation	1
Installation and Start-Up.....	1
Air Supply	2
Air Inlet & Priming.....	2
ESADS+Plus®: Externally Serviceable Air Distribution System	2
Air Exhaust	3
Between Uses	3
Check Valve Servicing	3
Diaphragm Servicing	3
Reassembly	4
Pilot Valve	4
Pilot Valve Actuator.....	4
Service Instructions: Troubleshooting	5
Important Safety Information	6
Recycling	6
Grounding The Pump	7
Material Codes	8-9
Composite Repair Parts List.....	8-9
Composite Repair Drawing.....	10
Declaration of Conformity	11

PRINCIPLE OF PUMP OPERATION

This flap swing check valve pump is powered by compressed air and is a 1:1 pressure ratio design. It alternately pressurizes the inner side of one diaphragm chamber, while simultaneously exhausting the other inner chamber. This causes the diaphragms, which are connected by a common rod, to move endwise. Air pressure is applied over the entire surface of the diaphragm, while liquid is discharged from the opposite side. The diaphragm operates under a balanced condition during the discharge stroke, which allows the unit to be operated at discharge heads over 200 feet (61 meters) of water head.

Since the diaphragms are connected by a common rod, secured by plates to the center of the diaphragms, one diaphragm performs the discharge stroke, while the other is pulled to perform the suction stroke in the opposite chamber.

For maximum diaphragm life, keep the pump as close to the liquid being pumped as possible. Positive suction head in excess of 10 feet of liquid (3.048 meters) may require a back pressure regulating device. This will maximize diaphragm life.

Alternate pressuring and exhausting of the diaphragm chamber is performed by means of an externally mounted, pilot operated, four-way spool type air distribution valve. When the spool shifts to one end of the valve body, inlet air pressure is applied to one diaphragm chamber and the other diaphragm chamber exhausts. When the spool shifts to the opposite end of the valve body, the porting of chambers is reversed. The air distribution valve spool is moved by an internal pilot valve which alternately pressurizes one side of the air distribution valve spool, while exhausting the other side. The pilot valve is shifted at each end of the diaphragm stroke by the diaphragm plate coming in contact with the end of the pilot spool. This pushes it into position for shifting of the air distribution valve.

The chambers are manifolded together with a suction and discharge flap-type check valve for each chamber, maintaining flow in one direction through the pump.

INSTALLATION & START-UP

Locate the pump as close to the product being pumped as possible, keeping suction line length and number of fittings to a minimum. Do not reduce line size.

For installations of rigid piping, short flexible sections of hose should be installed between pump and piping. This reduces vibration and strain to the piping system. A surge suppressor is recommended to further reduce pulsation in flow.

This pump was tested at the factory prior to shipment and is ready for operation. It is completely self-priming from a dry start for suction lifts of 20 feet (6.096 meters) or less. For suction lifts exceeding 20 feet of liquid, fill the chambers with liquid prior to priming.

AIR SUPPLY

Air supply pressures cannot exceed 125 psi (8.61 bar). Connect the pump air inlet to an air supply of sufficient capacity and pressure required for desired performance. When the air line is solid piping, use a short length of flexible hose [not less than 3/4" (19mm) in diameter] between pump and piping to eliminate strain to pipes.

AIR INLET & PRIMING

For start-up, open an air valve approximately 1/2" to 3/4" turn. After the unit primes, an air valve can be opened to increase flow as desired. If opening the valve increases cycling rate, but does not increase flow rate, cavitation has occurred, and the valve should be closed slightly.

For the most efficient use of compressed air and the longest diaphragm life, throttle the air inlet to the lowest cycling rate that does not reduce flow.

A NOTE ABOUT AIR VALVE LUBRICATION

The SANDPIPER pump's pilot valve and main air valve assemblies are designed to operate WITHOUT lubrication. This is the preferred mode of operation. There may be instances of personal preference, or poor quality air supplies when lubrication of the compressed air supply is required. The pump air system will operate with properly lubricated compressed air supplies. Proper lubrication of the compressed air supply would entail the use of an air line lubricator (available from Warren Rupp) set to deliver one drop of 10 wt., non-detergent oil for every 20 SCFM of air the pump consumed at its point of operation. Consult the pump's published Performance Curve to determine this.

It is important to remember to inspect the sleeve and spool set routinely. It should move back and forth freely. This is most important when the air supply is lubricated. If a lubricator is used, oil accumulation will, over time, collect any debris from the compressed air. This can prevent the pump from operating properly.

Water in the compressed air supply can create problems such as icing or freezing of the exhaust air causing the pump to cycle erratically, or stop operating. This can be addressed by using a point of use air dryer to supplement a plant's air drying equipment. This device will remove excess water from the compressed air supply and alleviate the icing or freezing problem.

ESADS: EXTERNALLY SERVICEABLE AIR DISTRIBUTION SYSTEM

Please refer to the exploded view drawing and parts list in the Service Manual supplied with your pump. If you need replacement or additional copies, contact your local Warren Rupp Distributor. To receive the correct manual, you must specify the MODEL and TYPE information found on the name plate of the pump.

MODELS WITH 1" SUCTION/DISCHARGE OR LARGER, AND METAL CENTER SECTIONS:

The main air valve sleeve and spool set is located in the valve body mounted on the pump with four hex head capscrews. The valve body assembly is removed from the pump by removing these four hex head capscrews.

With the valve body assembly off the pump, access to the sleeve and spool set is made by removing four hex head capscrews (each end) on the end caps of the valve body assembly. With the end caps removed, slide the spool back and forth in the sleeve. The spool is closely sized to the sleeve and must move freely to allow for proper pump operation. An accumulation of oil, dirt or other contaminants from the pump's air supply, or from a failed diaphragm, may prevent the spool from moving freely. This can cause the spool to stick in a position that prevents the pump from operating. If this is the case, the sleeve and spool set should be removed from the valve body for cleaning and further inspection.

Remove the spool from the sleeve. Using an arbor press or bench vise (with an improvised mandrel), press the sleeve from the valve body. Take care not to damage the sleeve. At this point, inspect the o-rings on the sleeve for nicks, tears or abrasions. Damage of this sort could happen during assembly or servicing. A sheared or cut o-ring can allow the pump's compressed air supply to leak or bypass within the air valve assembly, causing the pump to leak compressed air from the pump air exhaust or not

cycle properly. This is most noticeable at pump dead head or high discharge pressure conditions. Replace any of these o-rings as required or set up a routine, preventive maintenance schedule to do so on a regular basis. This practice should include cleaning the spool and sleeve components with a safety solvent or equivalent, inspecting for signs of wear or damage, and replacing worn components.

To re-install the sleeve and spool set, lightly lubricate the o-rings on the sleeve with an o-ring assembly lubricant or lightweight oil (such as 10 wt. air line lubricant). Re-install one end cap, gasket and bumper on the valve body. Using the arbor press or bench vise that was used in disassembly, carefully press the sleeve back into the valve body, without shearing the o-rings. You may have to clean the surfaces of the valve body where the end caps mount. Material may remain from the old gasket. Old material not cleaned from this area may cause air leakage after reassembly. Take care that the bumper stays in place allowing the sleeve to press in all the way. Reinstall the spool, opposite end cap, gasket and bumper on the valve body. After inspecting and cleaning the gasket surfaces on the valve body and intermediate, reinstall the valve body on the pump using new gaskets. Tighten the four hex head capscrews evenly and in an alternating cross pattern.

AIR EXHAUST

If a diaphragm fails, the pumped liquid or fumes can enter the air end of the pump, and be exhausted into the atmosphere. When pumping hazardous or toxic materials, pipe the exhaust to an appropriate area for safe disposition.

This pump can be submerged if materials of construction are compatible with the liquid. The air exhaust must be piped above the liquid level. Piping used for the air exhaust must not be smaller than 1" (2.54 cm). Reducing the pipe size will restrict air flow and reduce pump performance. When the product source is at a higher level than the pump (flooded suction), pipe the exhaust higher than the product source to prevent siphoning spills.

Freezing or icing-up of the air exhaust can occur under certain temperature and humidity conditions. Use of an air dryer unit should eliminate most icing problems.

BETWEEN USES

When used for materials that tend to settle out or transform to solid form, the pump should be completely flushed after each use, to prevent damage. Product remaining in the pump between uses could dry out or settle out. This could cause problems with valves and diaphragms at re-start. In freezing temperatures, the pump must be drained between uses in all cases.

CHECK VALVE SERVICING

Valve inspection requires removal of (4) $\frac{3}{8}$ " hex nuts. On the suction side the flange, when removed, carries the valve and seat as an assembly. On the discharge side, the valve and seat will stay with the diaphragm housing. Visual inspection and cleaning is possible. If parts are to be replaced, remove the self locking nuts and all parts are accessible.

DIAPHRAGM SERVICING

Diaphragms can be inspected or the diaphragm assembly removed without removing the suction and discharge flanges. Remove (8) nuts around the chamber flange, and the housing assembly will pull off. Check valves can be inspected for proper seating at this point as well as the diaphragm. Use care to keep foreign matter from behind the diaphragm. The opposite diaphragm may be inspected by the same procedure. If either diaphragm has to be replaced, follow closely these steps: Pull the outer diameter of one diaphragm off the (8) capscrews. NOTE: One side only! On the free diaphragm assembly, use a $\frac{3}{8}$ " allen wrench to turn the assembly (diaphragm, plates and screw) loose from the shaft. Once the assembly has turned, it will turn out by hand by use of the diaphragm. Now the opposite diaphragm assembly and the drive shaft will pull free from the capscrews and pump intermediate assembly. The interior components consisting of sleeve bearings, rod seals, and pilot valve actuator bushings are now accessible for service if required. Hold the shaft in a clamping device making sure to protect surface of shaft so as not to scratch or mar it in any way. The diaphragm assembly will turn loose. To disassemble the components, turn a $\frac{1}{4}$ "-20 capscrew by hand into the tapped hole in the inner plate. This keeps the plate from turning while the socket head capscrew is removed. To do this, place assembly in a vise so the two protruding ends of screws are loose in the vise jaws (about $\frac{3}{4}$ " apart). Turn the center screw loose from the back plate and the assembly will come apart.

REASSEMBLY

All procedures for reassembling the pump are the reverse of the previous instructions with further instructions as shown:

1. The diaphragm assemblies are to be installed with the natural bulge outward or toward the head of the center screw. Make sure both plates are installed with outer radii against the diaphragm. After all components are in position in a vise and hand tight, set a torque wrench for 480 inch pounds (40 ft. pounds) (54.23 Newton meters) using a (3/8") allen head socket. After each diaphragm sub assembly has been completed, thread one assembly into the shaft (held near the middle in a vise having soft jaws to protect the finish) making sure the stainless steel washer is in place on the capscrew.

Make sure 1/4"-20 mounting screw has been removed and that the bumper (Item #19 on drawing) is in place in the shaft.

Install this sub assembly into the pump and secure by placing the outer chamber housing and capscrews on the end with the diaphragm. This will hold the assembly in place while the opposite side is installed. Make sure the last diaphragm assembly is torqued to 30 ft. lbs. (40.67 Newton meters) before placing the outer diaphragm over the capscrews. If the holes in the diaphragm flange do not line up with the holes in the chamber flange, turn the diaphragm assembly in the direction of tightening to align the holes so that the capscrews can be inserted. This final torquing of the last diaphragm assembly will lock the two diaphragm assemblies together. Place remaining outer chamber on the open end and tighten down the securing nuts gradually and evenly on both sides.

Caution should be used while reassembling check valves. The valves are designed for some preload over the retainer hinge pad. This is done to insure proper face contact with the seat. After all parts are in place, tighten the lock nuts down on the assembly to the point where visual inspection shows that seat and valve face mate without gap. This is important for dry prime. However, after priming action has started, valves will function due to differential pressure without concern or trouble.

PILOT VALVE

The pilot valve assembly is accessed by removing the main air distribution valve body from the pump and lifting the pilot valve body out of the intermediate housing.

Most problems with the pilot valve can be corrected by replacing the o-rings. Always grease the spool prior to inserting it into the sleeve. If the sleeve is removed from the body, reinsertion must be at the chamfered side. Grease the o-rings to slide the sleeve into the valve body. Securely insert the retaining ring around the sleeve. When reinserting the pilot valve, push both plungers (located inside the intermediate bracket) out of the path of the pilot valve spool ends to avoid damage.

PILOT VALVE ACTUATOR

Bushings for the pilot valve actuators are threaded into the intermediate bracket from the outside. The plunger may be removed for inspection or replacement. First remove the air distribution valve body and the pilot valve body from the pump. The plungers can be located by looking into the intermediate. It may be necessary to use a fine piece of wire to pull them out. The bushing can be turned out through the inner chamber by removing the outer chamber assembly. Replace the bushings if pins have bent.

TROUBLESHOOTING

PROBLEM: Pump cycles but will not pump. (Note: higher suction lifts require faster cycling speed for priming.)

POSSIBLE CAUSES:

- A. Air leak in suction line.
- B. Excessive suction lift.
- C. Check valve not seating properly.
- D. Leakage at joint of suction manifold or elbow flange.
- E. Suction line or strainer plugged.
- F. Diaphragm ruptured.

PROBLEM: Pump will not cycle. (Note: Always disconnect air supply to relieve air pressure before disassembling any portion of pump.)

POSSIBLE CAUSES:

- A. Discharge hose or line plugged, or discharge head requirement greater than air supply pressure. (Disconnect discharge line to check.)
- B. Spool in air distribution valve not shifting. (Remove end cap and check spool — must slide freely.)
- C. Diaphragm ruptured. (Air will escape out discharge line in this case.)
- D. Blockage in diaphragm chamber preventing movement. (Shut off air supply and reopen after pressure is relieved.)

PROBLEM: Uneven discharge flow. (Indicates one chamber not operating properly.)

POSSIBLE CAUSES:

- A. Check valve not sealing properly in one chamber.
- B. Diaphragm failure in one chamber.
- C. Air leak at suction manifold joint or elbow flange one side.

For additional information, see the SANDPIPER Troubleshooting Guide.

RECOMMENDED ACCESSORIES TO MAXIMIZE PUMP PERFORMANCE:

- **Surge Suppressor:** For nearly pulse-free flow.
- **Filter/Regulator:** For modular installation and service convenience.

IMPORTANT SAFETY INFORMATION



IMPORTANT

Read these safety warnings and instructions in this manual completely, before installation and start-up of the pump. It is the responsibility of the purchaser to retain this manual for reference. Failure to comply with the recommendations stated in this manual will damage the pump, and void factory warranty.



WARNING

Take action to prevent static sparking. Fire or explosion can result, especially when handling flammable liquids. The pump, piping, valves, containers or other miscellaneous equipment must be grounded. (See page 32)



WARNING

This pump is pressurized internally with air pressure during operation. Always make certain that all bolting is in good condition and that all of the correct bolting is reinstalled during assembly.



CAUTION

Before pump operation, inspect all gasketed fasteners for looseness caused by gasket creep. Retorque loose fasteners to prevent leakage. Follow recommended torques stated in this manual.



WARNING

When used for toxic or aggressive fluids, the pump should always be flushed clean prior to disassembly.



WARNING

Before maintenance or repair, shut off the compressed air line, bleed the pressure, and disconnect the air line from the pump. The discharge line may be pressurized and must be bled of its pressure.



WARNING

Before doing any maintenance on the pump, be certain all pressure is completely vented from the pump, suction, discharge, piping, and all other openings and connections. Be certain the air supply is locked out or made non-operational, so that it cannot be started while work is being done on the pump. Be certain that approved eye protection and protective clothing are worn all times in the vicinity of the pump. Failure to follow these recommendations may result in serious injury or death.



WARNING

In the event of diaphragm rupture, pumped material may enter the air end of the pump, and be discharged into the atmosphere. If pumping a product which is hazardous or toxic, the air exhaust must be piped to an appropriate area for safe disposition.



WARNING

Airborne particles and loud noise hazards. Wear ear and eye protection.

RECYCLING

Many components of SANDPIPER AODD pumps are made of recyclable materials (see chart on page 9 for material specifications). We encourage pump users to recycle worn out parts and pumps whenever possible, after any hazardous pumped fluids are thoroughly flushed.

Pump complies with EN809 Pumping Directive, Directive 98/37/EC Safety of Machinery, and Directive 94/9/EC, EN13463-1 Equipment for use in Potentially Explosive Environments. The Technical File No. AX1 is stored at KEMA, Notified Body 0344, under Document #203040000. See www.warrenrupp.com.



II 2GD c T5

Grounding The Pump

To be fully groundable, the pumps must be ATEX Compliant. Refer to pump data sheet for ordering.

⚠ WARNING ⚠
<i>Take action to prevent static sparking. Fire or explosion can result, especially when handling flammable liquids. The pump, piping, valves, containers or other miscellaneous equipment must be grounded.</i>

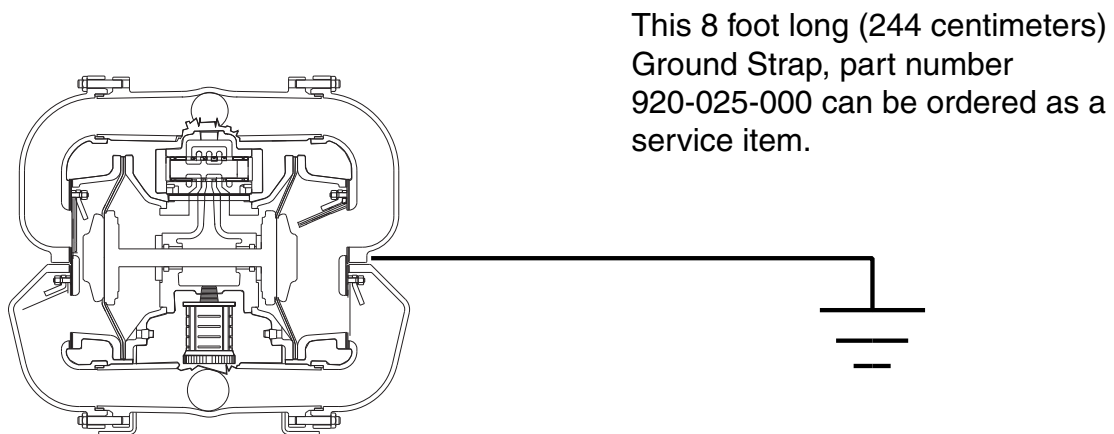
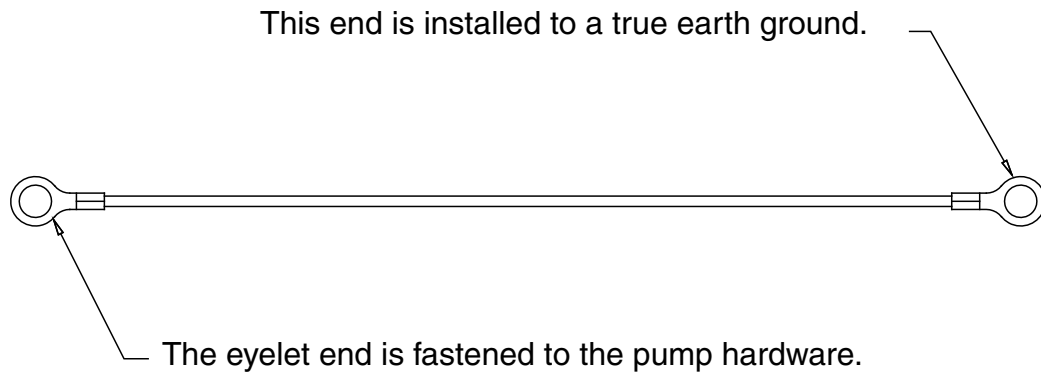

To reduce the risk of static electrical sparking, this pump must be grounded. Check the local electrical code for detailed grounding instruction and the type of equipment required, or in the absence of local codes, an industry or nationally recognized code having jurisdiction over specific installations.



II 2GD c T5



ITEM NO.	PART NUMBER	DESCRIPTION	TOTAL RQD.
1	070-006-170	Bearing, Sleeve	2
2	114-002-313	Bracket, Intermediate	1
3	720-004-360	Seal, U-Cup	2
4	135-008-000	Bushing, Threaded, w/O-Ring	
5	620-004-114	Plunger, Actuator	2
6	095-073-000	Pilot Valve Body Assembly¹	1
6-A	095-070-551	Pilot Valve Body	1
6-B	755-025-000	Sleeve (w/O-Ring)	1
6-C	560-033-360	O-Ring (Sleeve)	4
6-D	775-026-000	Spool (w/O-Ring)	1
6-E	560-023-360	O-Ring (Spool)	2
6-F	675-037-080	Retaining Ring	1
7	360-041-379	Gasket, Valve Body	1
8	560-001-360	O-Ring	2
9	095-043-313	Body, Valve	1
10	132-014-358	Bumper, Valve Spool	2
11	165-011-313	Cap, End	2
12	360-048-425	Gasket, Valve Body	1
13	360-010-425	Gasket, End Cap	2
14	560-020-360	O-Ring	6
15	031-012-000	Sleeve & Spool Set	1
16	170-032-115	Capscrew, Hex Head	8
17	170-045-115	Capscrew, Hex Head	4
18	115-062-315	Mounting Foot, Left Hand	2
19	132-002-360	Bumper, Diaphragm	2
20	196-001-313	Chamber, Inner	2
21	196-078-110	Chamber, Outer	2
22	286-007-366	Diaphragm	2
23	560-022-360	O-Ring	2
24	612-096-110	Plate, Diaphragm (Outer)	2
25	685-007-120	Rod, Diaphragm	1
26	170-023-115	Capscrew, Hex Head	8
27	170-024-115	Capscrew, Hex Head	8
28	618-003-110	Plug, Pipe (SS Pump Only)	2
29	115-063-315	Mounting Foot, Right Hand	2
30	171-002-110	Capscrew, Socket Head	2
31	545-007-115	Nut, Hex	16
32	807-008-115	Stud	16
33	900-006-330	Washer, Lock	8
34	612-047-330	Plate, Diaphragm	2
35	312-012-110	Elbow, Suction	2
36	312-013-110	Elbow, Discharge	2
37	338-005-366	Flap Valve	4
38	360-011-366	Gasket, Seat	4
39	360-012-608	Gasket, Flange	4
40	518-001-110TC	Manifold, Discharge, Suction	2
42	570-001-366	Pad, Hinge — Flap Valve	4
43	670-005-110	Retainer, Flap Valve	4
44	675-013-366	Ring, Sealing	4
45	722-004-110	Seat, Flap Valve	4

Repair Parts shown in **bold face (darker)** type are more likely to need replacement after extended periods of normal use.

They are readily available from most Warren Rupp distributors. The pump owner may prefer to maintain a limited inventory of these parts in his own stock to reduce repair downtime to a minimum.

IMPORTANT: When ordering repair parts always furnish pump model number, serial number and type number.

MATERIAL CODES

The Last 3 Digits of Part Number

- 000... Assembly, sub-assembly; and some purchased items
- 010... Cast Iron
- 015... Ductile Iron
- 025... Music Wire
- 080... Carbon Steel, AISI B-1112
- 110... Alloy Type 316 Stainless Steel
- 112... Alloy C
- 114... 303 Stainless Steel
- 115... 301/302/304 Stainless Steel
- 120... 416 Stainless Steel (Wrought Martensitic)
- 148... Hardcoat Anodized Aluminum
- 150... 6061-T6 Aluminum
- 151... 6063-T6 Aluminum
- 154... Almag 35 Aluminum
- 155 or 156... 356-T6 Aluminum
- 157... Die Cast Aluminum Alloy #380
- 159... Anodized Aluminum
- 162... Brass, Yellow, Screw Machine Stock
- 170... Bronze, Bearing Type, Oil Impregnated
- 180... Copper Alloy
- 313... White Epoxy Coated Aluminum
- 315... White Epoxy Coated Steel
- 330... Plated Steel
- 331... Chrome Plated Steel
- 332... Electroless Nickel Plated
- 335... Galvanized Steel
- 354... Injection Molded #203-40 Santoprene — Duro 40D +/-5; Color: RED
- 356... Hytrel
- 357... Ruppilon (Urethane Rubber)
- 360... Buna-N Rubber. Color coded: RED
- 363... FKM (Fluorel). Color coded: YELLOW
- 364... E.P.D.M. Rubber. Color coded: BLUE
- 365... Neoprene Rubber. Color coded: GREEN
- 366... FDA Accepted White Nitrile. Color coded: WHITE

Delrin and Hytrel are registered tradenames of E.I. DuPont.

Gylon is a registered tradename of Garlock, Inc.

Ryton is a registered tradename of Phillips Chemical Company.

Loctite is a registered tradename of Loctite Corporation.

¹Available in kit form. Order P/N 031-055-000 which also includes items 5, 7, 12 & 64.

ITEM NO.	PART NUMBER	DESCRIPTION	TOTAL RQD.
46	770-005-115	Spacer	2
47	807-018-110	Stud	8
48	170-052-115	Capscrew, Hex Head	2
49	170-033-115	Capscrew, Hex Head	2
50	545-005-115	Nut, Hex	24
51	900-005-115	Washer, Lock	28
52	547-002-110	Nut, Stop	8
53	902-003-000	Stat-O-Seal	2
54	530-036-000	Muffler, Exhaust	1
55	560-046-360	O-Ring	2
	560-070-610	O-Ring	2
57	612-007-313	Plate, Base	1
59	170-018-115	Capscrew, Hex Head	8
62	031-019-313	Main Air Valve Assembly	1
64	132-022-360	Bumper	2
66	350-001-360	Foot, Rubber	4
67	901-005-115	Washer, Flat	4
68	901-022-115	Washer, Flat	8
69	901-038-115	Washer, Flat	4

Repair Parts shown in **bold face (darker)** type are more likely to need replacement after extended periods of normal use. They are readily available from most Warren Rupp distributors. The pump owner may prefer to maintain a limited inventory of these parts in his own stock to reduce repair downtime to a minimum.

IMPORTANT: When ordering repair parts always furnish pump model number, serial number and type number.

MATERIAL CODES
The Last 3 Digits of Part Number

- Continued from previous page*
- 375...Fluorinated Nitrile
 - 378...High density Polypropylene
 - 379...Conductive Nitrile
 - 384...Conductive Neoprene
 - 405...Cellulose Fibre
 - 408...Cork and Neoprene
 - 425...Compressed Fibre
 - 426...Blue Gard
 - 440...Vegetable Fibre
 - 465...Fibre
 - 500...Delrin 500
 - 501...Delrin 570
 - 505...Acrylic Resin Plastic
 - 520...Injection Molded PVDF Natural Color
 - 540...Nylon
 - 541...Nylon
 - 542...Nylon
 - 544...Nylon Injection Molded
 - 550...Polyethylene
 - 551...Polypropylene
 - 552...Unfilled Polypropylene
 - 553...Unfilled Polypropylene
 - 555...Polyvinyl Chloride
 - 558...Conductive HDPE
 - 570...Rulon II
 - 580...Ryton
 - 590...Valox
 - 591...Nylatron G-S
 - 592...Nylatron NSB
 - 600...PTFE (virgin material) Tetrafluoroethylene (TFE)
 - 601...PTFE (Bronze and moly filled)
 - 602...Filled PTFE
 - 603...Blue Gylon
 - 604...PTFE
 - 606...PTFE
 - 608...Conductive PTFE
 - 610...PTFE Encapsulated Silicon
 - 611...PTFE Encapsulated FKM

Delrin and Hytrel are registered tradenames of E.I. DuPont.

Gylon is a registered tradename of Garlock, Inc.

Nylatron is a registered tradename of Polymer Corp.

Rulon II is a registered tradename of Dixon Industries Corporation.

Ryton is a registered tradename of Phillips Chemical Company.

Valox is a registered tradename of General Electric Company.

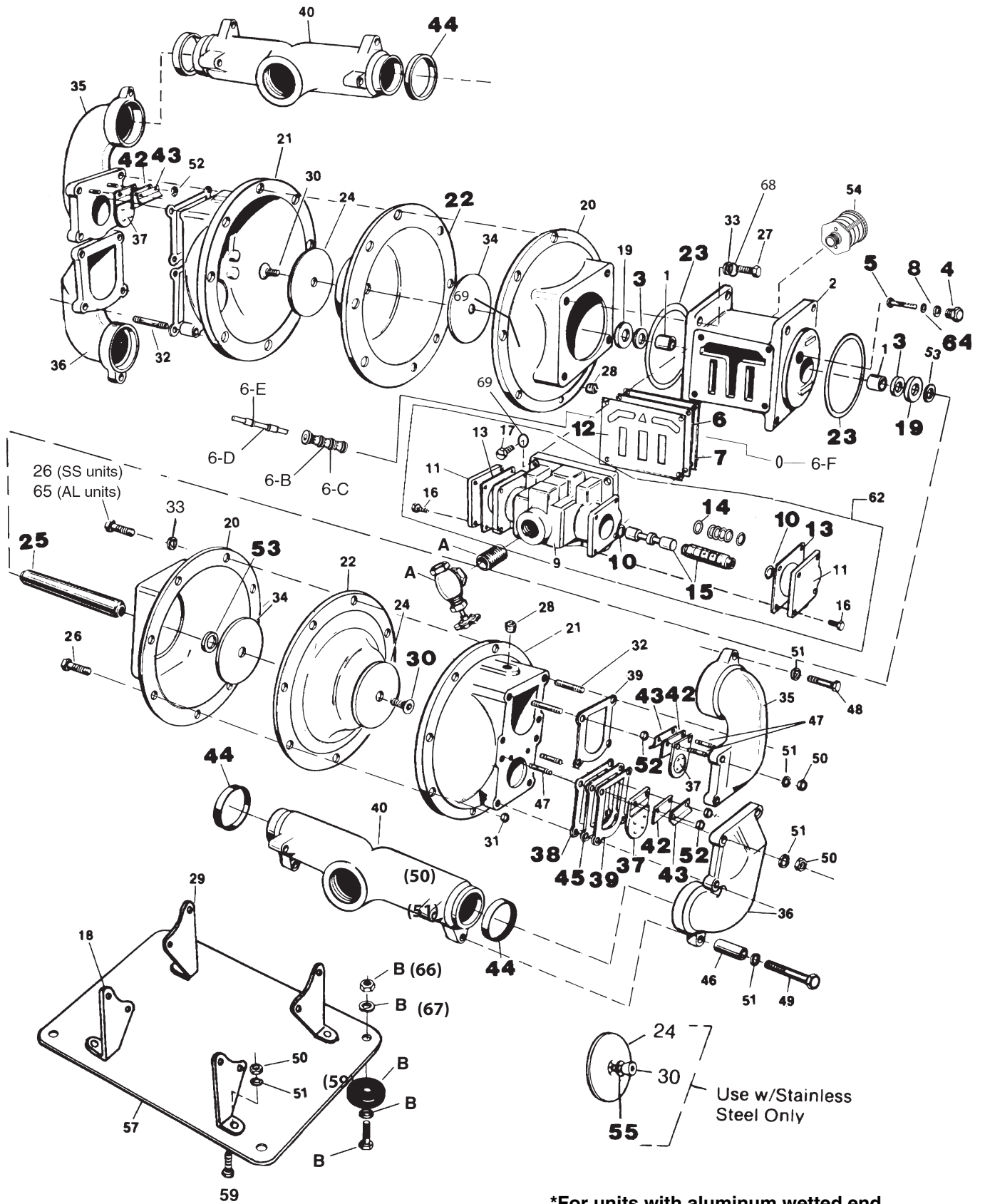

***For units with aluminum wetted end components only.**

A = Available as Kit # 475-102-000

B = Available as Kit # 475-101-000 (SA2 Only)
(Parts Included on TSA2)



**WARREN
RUPP®**

IREX
FLUID & METERING

Declaration of Conformity

Warren Rupp, Inc., 800 North Main Street, Mansfield, Ohio, certifies that Air-Operated Double Diaphragm Pumps Series: HDB, HDF, M Non-Metallic, S Non-Metallic, M Metallic, S Metallic, T series, G series, U series, EH and SH High Pressure, W series, SMA and SPA Submersibles, and Tranquillizer Surge Suppressors comply with the European Community Directive 98/37/EC, Safety of Machinery. This product has used Harmonized Standard EN 809, Pumps and Pump Units for Liquids - Common Safety Requirements, to verify conformance.



Signature of authorized person

October 20, 2005
Date of issue

David Roseberry
Printed name of authorized person

Engineering Manager
Title

Revision level A

August 6, 2008
Date of revision

CE

Declaration of Conformity

Declaration of Conformity

